



S I L I C O N L A B S

Extending Battery Life

Smart Metering Solutions

Silicon Labs Metering Solutions



Meter
Collector

Electronic
Meter

Metering
Transponder

EZRadioPRO
MCU

EZRadioPRO
MCU

EZRadioPRO
MCU

Isolators
Modems

Isolators

Isolators
FM Rx (RDS)

Energy
Displays



Intelligent
Thermostat



Utility Load
Control



Point Load
Control



Metering System Requirements

| | | |
|---|-------------------------------------|---|
| Control & Calibration Varies by type of meter, compensate for small variations in the measuring mechanism | <input checked="" type="checkbox"/> | C8051F9xx Low Power MCUs |
| Quantitative Measurement Varies by meter type but includes temp sensors, flow sensors, shunt resistor, isolation transformer, current transformer, and time keeping | <input checked="" type="checkbox"/> | C8051F9xx Low Power MCUs with embedded RTC |
| Communications Configure parameters in the meter and transfer stored data to a host via wired or wireless connection | <input checked="" type="checkbox"/> | Si4x3x EZRadioPRO radios ISOmodem Embedded Modems |
| Power Management Low-power and system robustness in the event of a primary source of energy goes down | <input checked="" type="checkbox"/> | C8051F9xx MCUs High efficiency PWM controller for AC/DC conversion |
| Display Interface to low cost and low power LCD and LED displays in seven-segment, alphanumeric or matrix format | <input checked="" type="checkbox"/> | LCD controller capability |
| Synchronization Reliable transmission of data to central hub to enable data analysis and accurate billing | <input checked="" type="checkbox"/> | Si4x3x EZRadioPRO radios Si47xx FM Radio with RDS |

Control & Calibration - C8051F9xx MCUs

- ◆ Key element to metering design is ability to wake up quickly, capture measurements and go to sleep quickly

- ◆ C8051F9xx 8-bit core optimized for this environment
 - 170 $\mu\text{A}/\text{MHz}$ active current @ 25 MHz
 - 600 nA sleep current with RTC active
 - 50 nA sleep current with RTC disabled
 - 25 MIPS operation with $\sim 2\mu\text{s}$ wakeup from sleep
 - 3.3 μs analog acquisition time from lowest power mode

- ◆ Integrated battery monitoring
 - ADC can be utilized to detect battery failure and save results
 - Programmable output can supply power to other chips in the system (i.e. radio)

- ◆ Multiple internal clock sources
 - Multiple clock sources allow optimal clock planning for lowest power operation

- ◆ Integrated real-time clock with programmable alarm
 - Provides versatile mechanism for scheduling events

Communication - Wireless

- ◆ Most residential and industrial meters use short range wireless connectivity to send data to an aggregator
 - EZRadioPRO™ receivers and transceivers are ideal for this application
- ◆ Robust link performance — increased data reliability
 - Greatest sensitivity, programmable up to 20 dBm
 - Industry-leading link budget (138 dBm)
- ◆ Simplified system design — key features are built in
 - Simplified BOM and low operating currents
 - Integrated high-performance power amplifier and low-noise amplifier
- ◆ Increased communication range — more than 3km
 - Built-in antenna diversity algorithm
 - Packet handler, wake timer, low-battery detect enable additional features.



**EZRadioPRO™
Short Range Wireless ICs**



EZRadioPRO Simplifies Wireless Design

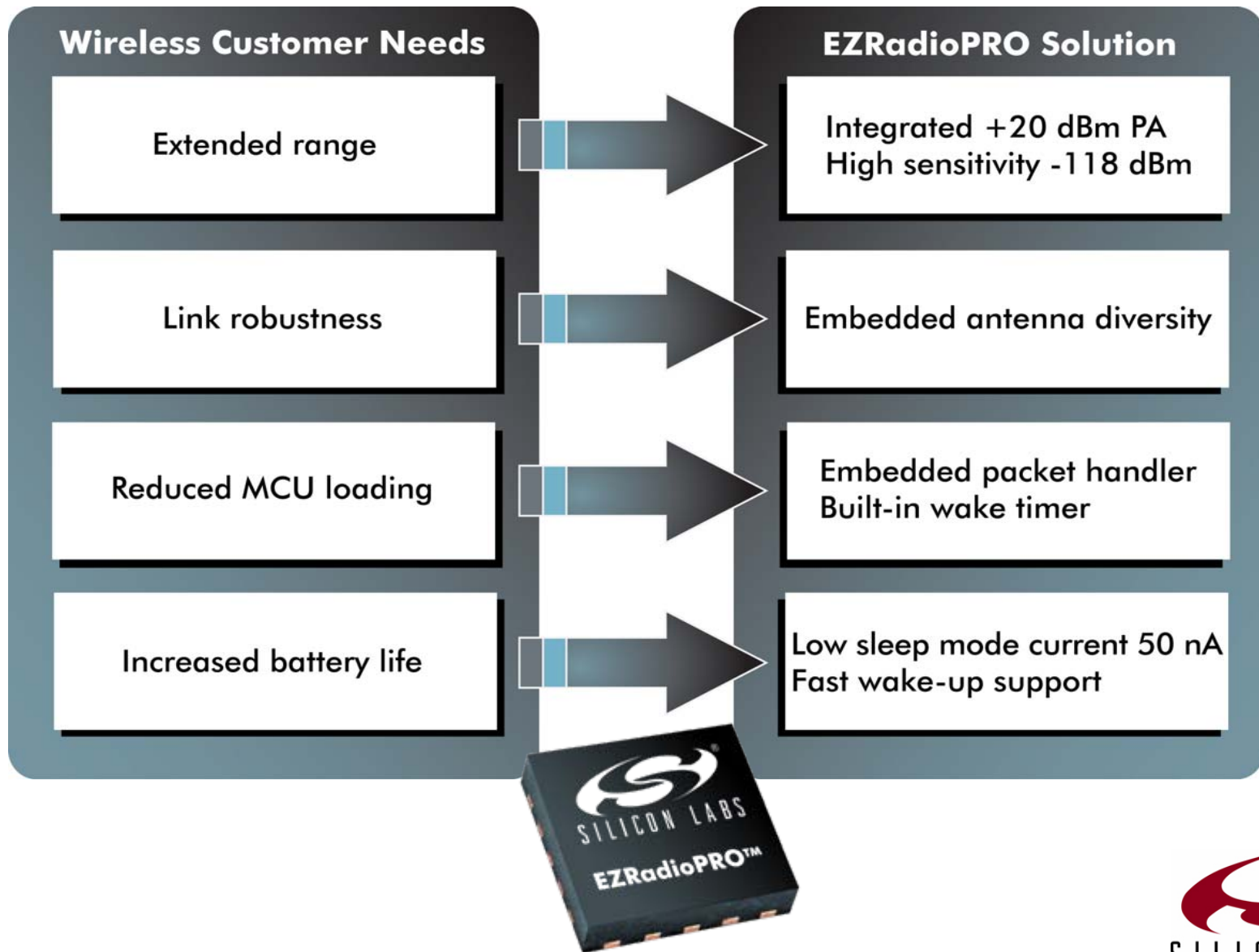

Reduced MCU Loading

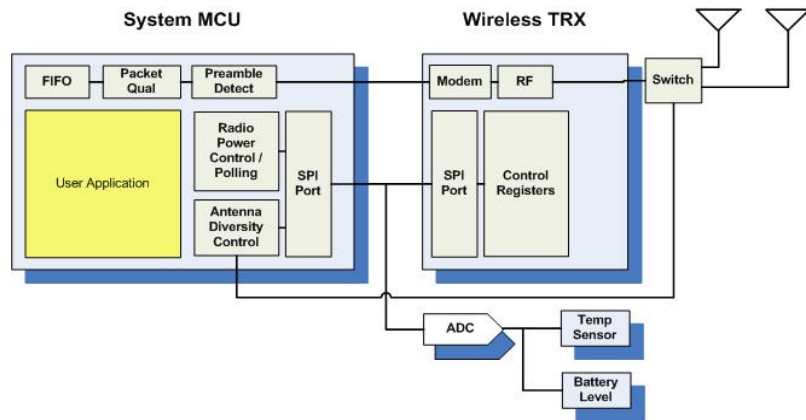

Competitive System Solutions

- ◆ Larger MCU memory requirement
- ◆ MCU awake to poll memory—more current
- ◆ ADC required for temp/battery sensor detect
- ◆ *Reduced performance and battery life, cost, complicated design*

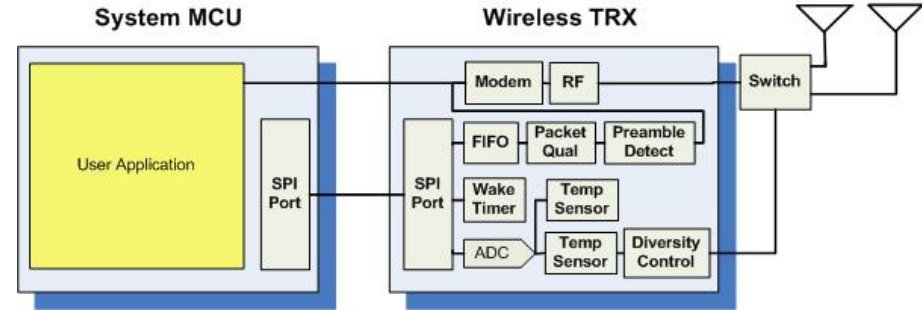

EZRadioPRO System Solution

- ◆ Reduced MCU memory requirement
- ◆ MCU asleep while MCU qualifies data
- ◆ Integrated ADC, temp sensor, battery detect
- ◆ *EZRadioPRO improves performance, reduces current and cost, eases design*

When using EZRadioPRO the MCU is freed up to support customer specific processing requirements

Increased Battery Life

- ◆ EZRadioPRO power saving features:
 - Multiple sleep modes support the most energy efficient configuration
 - Reduced Tx current consumption
 - Reduced wasted current during fast startup
 - Embedded functionality reduces MCU burden
- ◆ F9xx power saving features:
 - Integrated dc-dc converter powers MCU and EZRadioPRO
 - Fast startup times
 - Ultra low power sleep and active mode currents
 - MCU can sleep for up to 36hrs with no intermediate wake-up events
- ◆ Combination = lowest power solution

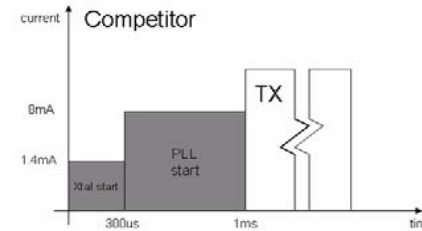

Consumed charge during wake up
 $1.4 \times 300 + 8 \times 700 =$
6020 [mAus]

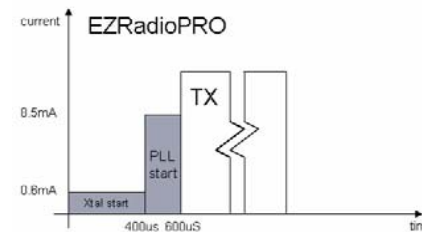

Consumed charge during wake up
 $0.6 \times 400 + 8.5 \times 200 =$
1940 [mAus]



Complete Smart Metering IC Provider

- ◆ Broad portfolio of products ideal for intelligent metering
 - Ongoing strategic investment in metering market
- ◆ Products optimized for power and performance
 - Industry leading power/ performance ratio
- ◆ Backed by comprehensive tools and support
 - Software, reference designs and configuration tools





S I L I C O N L A B S

www.silabs.com