

Precision Clocking Solutions

SONET/SDH CLOCK MULTIPLIERS/JITTER ATTENUATORS

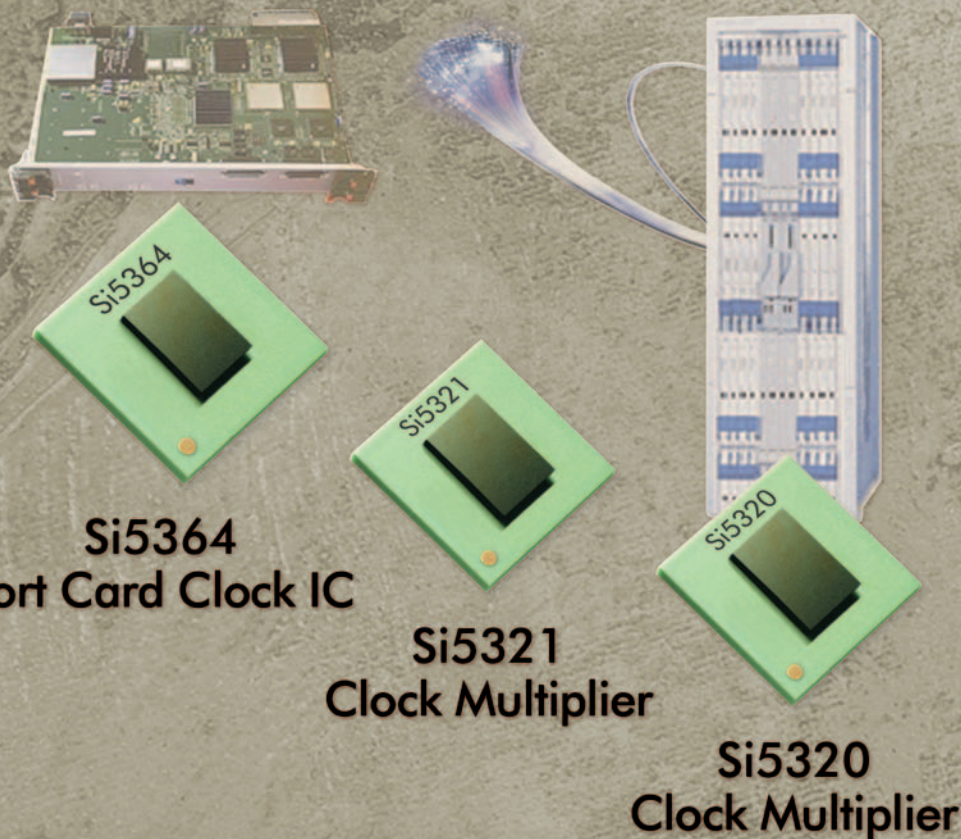

**Si5364
Port Card Clock IC**

**Si5321
Clock Multiplier**

**Si5320
Clock Multiplier**

DESCRIPTION

Silicon Laboratories' family of SONET/SDH clock multipliers/jitter attenuators provides the industry's best performance while requiring the least amount of board space. Offering jitter generation of less than $0.3\text{ps}_{\text{RMS}}$ (OC-192/STM-64), these devices outperform discrete implementations and hybrid clock solutions while integrating features like selectable forward error correction (FEC), frequency scaling, pin selectable loop filter bandwidths, and Stratum compliant hitless switching. Based on Silicon Laboratories' DSPLL™ technology, these clock ICs provide a fully integrated PLL eliminating the need for sensitive external loop filter components and costly VCXOs. A complete family of clocking solutions is available including single input/output devices as well as multiple input/output devices with hitless switching.

SYSTEM BENEFITS

- Small size saves board space
- Frequency agility reduces bill-of-materials
- DSPLL technology reduces external component count
- Enhanced functionality simplifies design and saves cost

APPLICATIONS

- Optical port cards/line cards
- Optical routers/switches
- Add/drop multiplexers
- Metro and edge equipment

KEY PRODUCTS

Si5364 Port Card Clock IC

- Stratum compliant hitless switching among three 19.44 MHz clock inputs
- Jitter generation less than $0.3\text{ps}_{\text{RMS}}$ (OC-192)
- Jitter attenuation with programmable PLL bandwidths
- Four programmable clock outputs at 19, 155 or 622 MHz
- Automatic or manual clock switching
- FEC scaling (255/238)
- Small size: 11 x 11 mm BGA package

Si5321 Clock Multiplier

- Jitter generation less than $0.3\text{ps}_{\text{RMS}}$ (OC-192)
- Clock input/output centered at 19, 38, 77, 155, 311, 622, 1244 or 2488 MHz
- Forward and reverse FEC clock scaling (255/238, 255/237, 66/64)
- Selectable loop filter bandwidths of 800 to 12800 Hz
- Low power: 445 mW (3.3 V operation)
- Small size: 9 x 9 mm BGA package

Si5320 Clock Multiplier

- Jitter generation less than $0.3\text{ps}_{\text{RMS}}$ (OC-192)
- Clock input/output centered at 19, 155, 622 MHz
- Forward and reverse FEC clock scaling (255/238)
- Selectable loop filter bandwidths of 800 to 12800 Hz
- Low power: 445 mW (3.3 V operation)
- Small size: 9 x 9 mm BGA package

SOLUTIONS GUIDE

THE STANDARD IN
ULTRA-LOW JITTER
CLOCK GENERATION DEVICES



SILICON LABORATORIES

Precision Clocking Solutions

ULTRA-LOW JITTER. SMALL SIZE. INNOVATIVE PLL DESIGN.

Jitter Attenuation

Silicon Laboratories' family of precision clock multipliers/jitter attenuators provides selectable loop filter bandwidths to minimize system clock jitter. Available loop bandwidth settings are 800, 1600, 3200, 6400 and 12800 Hz.

FEC Scaling

These clock ICs provide the appropriate clock scaling to translate between standard SONET/SDH reference clock frequencies and forward error correction (FEC) frequencies. The maximum clock output includes 693 MHz and 2.77 GHz (Si5321) for 10 GbE FEC support.

Hitless Switching

The Si5364 provides reference monitoring and clock switching that support Stratum 2/3/3E and SMC requirements. Clock switching can be automatic or manually controlled.

Small Size

These devices provide 5x to 20x space savings compared to traditional solutions using discretely implemented PLLs or clock modules.

Proprietary DSPLL Technology

The PLL within these devices utilizes digital signal processing to provide superior jitter performance while keeping all VCO and loop filter circuitry internal to the device. This level of integration makes the PLL less susceptible to board level noise, improving jitter performance.

Simplified Clock Multiplication/Jitter Attenuation

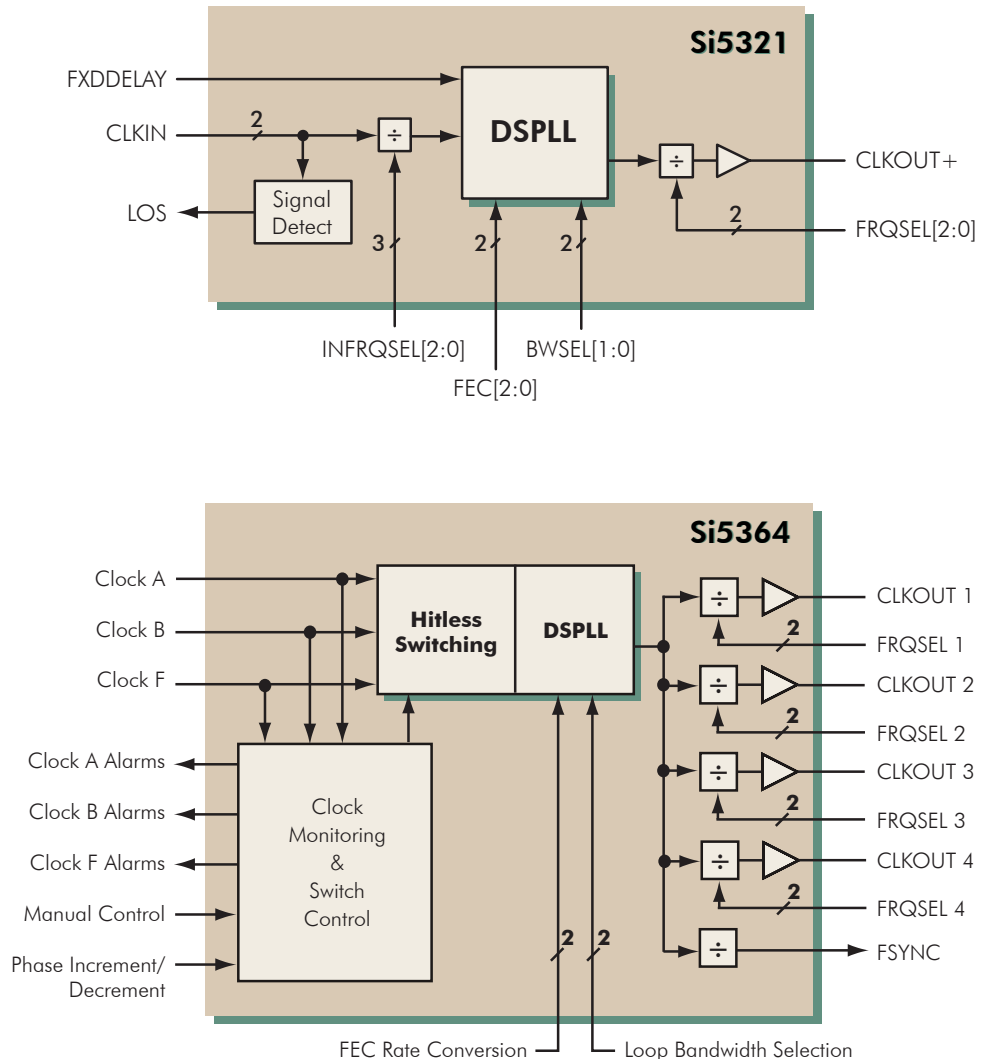

CONTACT INFORMATION



SILICON LABORATORIES

Silicon Laboratories Inc.

4635 Boston Lane • Austin, TX 78735

Toll Free: (877) 444-3032

Email: ClockInfo@silabs.com

Web site: www.silabs.com

DSPLL, Silicon Laboratories and the Silicon Laboratories logo are trademarks of Silicon Laboratories Inc.

A, 5000, October 03, Rev B

ORDERING INFORMATION

Product

Si5364-BC

Si5321-BC

Si5320-BC

Description

SONET/SDH Precision Port Card Clock IC

SONET/SDH Precision Clock Multiplier IC

SONET/SDH Precision Clock Multiplier IC

Data Sheets

Si5364-DS

Si5364-EVB-DS

Si5321-DS

Si5321-EVB-DS

Si5320-DS

Si5320-EVB-DS

Si5364 Data Sheet

Si5364 Evaluation Board Data Sheet

Si5321 Data Sheet

Si5321 Evaluation Board Data Sheet

Si5320 Data Sheet

Si5320 Evaluation Board Data Sheet

Evaluation Boards

Si5364-EVB

Si5321-EVB

Si5320-EVB

Si5364 Evaluation Board

Si5321 Evaluation Board

Si5320 Evaluation Board