

# Si3000 Voice Codec

VOICE CODEC WITH MICROPHONE AMPLIFIER,  
HEADPHONE DRIVER, AND HANDSET HYBRID



## FEATURES

- 84 dB dynamic range A/D Converter
- 84 dB dynamic range D/A Converter
- 16 bit resolution
- Microphone input
  - Programmable gain of 0, +10, +20, +30 dB
- Line level input (1Vrms)
- 3:1 analog input mixer
- Headphone output
  - Capable of driving a 32  $\Omega$  load
- Line level output (1 Vrms)
- Integrated handset hybrid
- Digital input/output gain
  - Programmable range of +12.5 to -34.5 dB
  - 1.5 dB step resolution
- 3.3V or 5V operation
- 50 mW power consumption
- Low profile 16-pin small outline package (SOIC)
- Supports daisy-chaining with Si3034/44 or Si3035 silicon DAAs for single DSP serial port operation

## APPLICATIONS

- Modems with Voice Channel – Speakerphone
- PC Card Modems with Cellular Telephone Support
- Web Phone
- Fax Machines with Handset Support
- Voice Recognition Systems
- Consumer/Computer Telephony

## PRODUCT DESCRIPTION

The Si3000 is a complete codec solution for voice applications (<12 kHz sample rate) requiring a low cost, high integration voice codec. The device integrates a microphone amplifier, 3:1 analog input mixer, +12.5 to -34.5 dB of programmable input/output digital gain, headphone driver, and an integrated handset hybrid for direct connection to an analog telephone. Programmable gain and attenuation settings are available on both the A/D converter and D/A converter signal paths with 1.5 dB step resolution. The gain/attenuation is implemented using a zero crossing technique to enable “click-free” level transitions. Operation from a single +5V or a single +3.3V power supply make the device suitable for low power portable applications.

## Si3000 VOICE CODEC

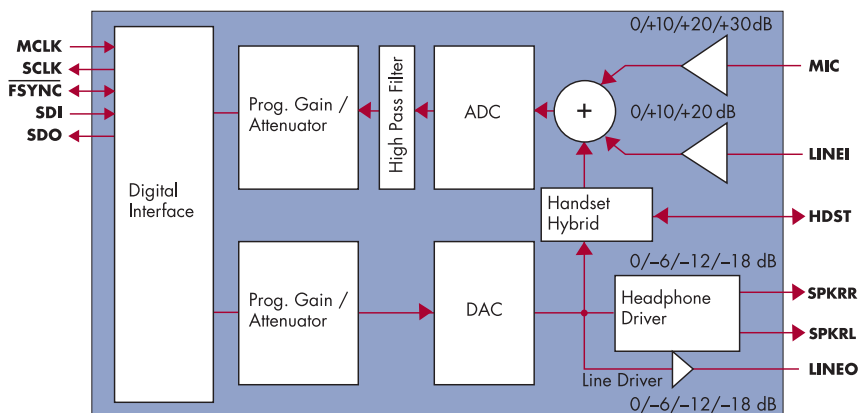

## PRODUCT BRIEF

THE Si3000 VOICE CODEC

WITH A SILICON LABS DAA OFFERS

A COMPLETE MIXED-SIGNAL

VOICE/MODEM SOLUTION.



SILICON LABORATORIES

## COMPLETE MIXED-SIGNAL MODEM SOLUTIONS

The Si3000, when used in conjunction with the Silicon Labs Si3035 North American DAA or the Si3034/44 International DAA, forms a complete mixed-signal input/output solution for data/fax/voice modems, fax machines, and web phone products. When coupled with the advanced features of the Si3044 that specifically target voice applications, a feature-rich solution suitable for any voice application using the PSTN is achieved. For easy operation, the Si3000 voice codec and Silicon Labs' DAA may share a single DSP serial port using the daisy-chaining operation of the Si3035/34/44 DAAs. In this operating mode, the DAA is the system master utilizing the first 16 bit timeslot and the Si3000 is configured as a slave utilizing the second 16 bit timeslot of a sample period. The Si3000 voice codec and Silicon Labs' DAAs are both capable of operating from a single +3.3V or single +5V power supply.

## 60% Area Reduction and 30% Cost Savings

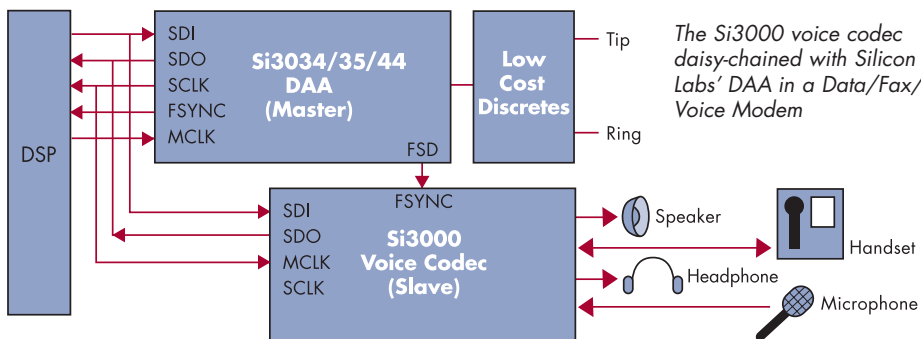

The Si3000 voice codec daisy-chained with Silicon Labs' DAA in a Data/Fax/Voice Modem

The Si3000 is packaged in a 16 pin SOIC surface mount package, and it requires only a few external low cost discrete components to offer a complete voice channel solution, enabling a 60% board space reduction and a 30% cost reduction versus competitive solutions consisting of a separate microphone amplifier, discrete handset hybrid, discrete microphone bias circuit, and an external headphone amplifier.

With all these features included, the Si3000 offers not only a voice codec, but also all of the analog support circuitry required to implement most voice applications. The microphone pre-amp includes not only a selectable 0-30 dB gain in addition to the digital volume control, but also includes full support for powered microphones with a complete microphone bias circuit.

The Si3000 also includes a fully integrated handset hybrid providing a complete handset solution with minimal external components required.

## CONTACT INFORMATION



SILICON LABORATORIES

### Silicon Laboratories Inc.

4635 Boston Lane • Austin, TX 78735

Toll Free: 1 (877) 444-3032

Email: [productinfo@silabs.com](mailto:productinfo@silabs.com)

Web site: [www.silabs.com](http://www.silabs.com)

ISOCap, Silicon Laboratories, and the Silicon Laboratories logos are trademarks of Silicon Laboratories Inc.

PB:Si3000; REG-5,000-June00

## ORDERING INFORMATION

| Part Number   | Description                  |
|---------------|------------------------------|
| Si3000-KS     | Voice Codec, 0 to 70°C       |
| Si3000SSI-EVB | Voice Codec Evaluation Board |

### Documentation

|                  |                             |
|------------------|-----------------------------|
| Si3000-DS        | Product Data Sheet          |
| Si3000SSI-EVB-DS | Evaluation Board Data Sheet |