

Si3216 Wideband ProSLIC™

PROGRAMMABLE SLIC/WIDEBAND CODEC WITH RINGING AND BATTERY VOLTAGE GENERATION

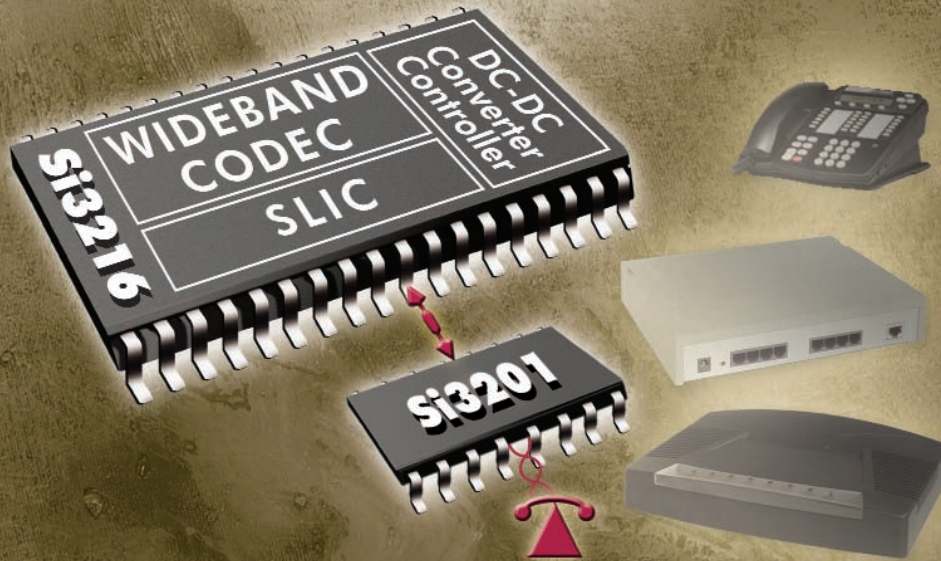

PRODUCT DESCRIPTION

The Si3216 ProSLIC™ is the world's first integrated SLIC/codec solution to provide both wideband (50 Hz to 7.0 kHz) and narrowband (200 Hz to 3.4 kHz) audio codec modes for enhanced voice quality in Voice-over-IP (VoIP) applications. The Si3216 delivers high-fidelity voice quality at a fraction of the cost. Like the Si3210, the Si3216 integrates subscriber line interface circuit (SLIC), codec and battery generation functionality into a single low-voltage CMOS integrated circuit. Combined with Silicon Laboratories' new Si3201 linefeed integrated circuit, the Si3216 packs maximum performance and flexibility into a 1.5 in² footprint, making it the smallest single-channel telephony interface available.

The integrated battery supply continuously adapts voltage to minimize power and enables the entire solution to be powered from a single 3.3 V or 5 V supply. Software configurable features include 5 REN internal ringing up to 90 V_{PK}, dual-tone audio generation and an enhanced set of telephony linefeed and signaling capabilities for global operation with only one hardware solution. The Si3216 is pin-for-pin, and software, compatible with the Si3210 and is packaged in a 38-pin TSSOP. The Si3201 is packaged in a thermally-enhanced 16-pin SOIC.

ProSLIC BLOCK DIAGRAM

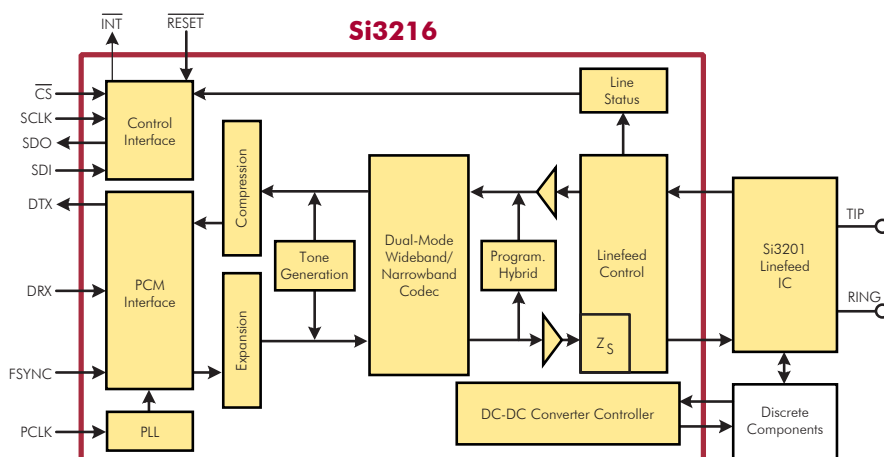

FEATURES

- Performs all battery, overvoltage, ringing, supervision, coding, hybrid and test (BORSCHT) functions
- Dual-mode wideband (50 Hz to 7.0 kHz)/ narrowband (200 Hz to 3.4 kHz) audio codec with 16-bit, 16 kHz sampling for high fidelity audio
- Adaptive battery voltage generation minimizes power in all operating modes
- Entire solution can be powered from a single 3.3 V or 5 V supply
- 5 REN sinewave or trapezoid internal ringing up to 90 V_{PK}
- Software programmable parameters for global compliance with one hardware solution:
 - Ringing amplitude, frequency and cadence
 - Constant current loop feed (20–41 mA)
 - Ring trip/loop closure thresholds and filtering
 - 2-wire AC impedance and transhybrid balance
- Extensive telephony signaling capabilities:
 - DTMF and FSK (caller ID)
 - Polarity reversal
- Audio loopback, DC and GR-909 subscriber line diagnostic capabilities
- Configurable PCM/SPI digital interface

APPLICATIONS

- Wideband VoIP CPE systems
- Voice-over-broadband (VoB) systems
- Terminal adapters: ISDN, Ethernet, USB
- PBX/IP-PBX/key telephone systems
- Computer telephony

PRODUCT BRIEF

**HIGH-FIDELITY VOICE IN THE
SMALLEST ANALOG TELEPHONY
INTERFACE AVAILABLE**



SILICON LABORATORIES

INTEGRATED SLIC, WIDEBAND CODEC AND BATTERY SUPPLY

Enhanced Audio Performance

The Si3216 delivers enhanced audio dynamic range and frequency response to today's VoIP and VoB applications. The Si3216 provides high-fidelity voice quality at a fraction of the cost. The Si3216 can switch on the fly between traditional narrowband and wideband audio modes.

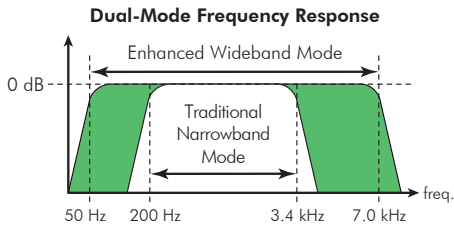

Integrated Battery Supply

The integrated DC-DC converter controller eliminates the need for designing bulky, expensive high-voltage power supplies, as the entire ProSLIC solution can operate from a single 3.3 V or 5 V power supply. The ProSLIC continuously adapts battery output voltage to minimize power for all operating modes and line conditions.

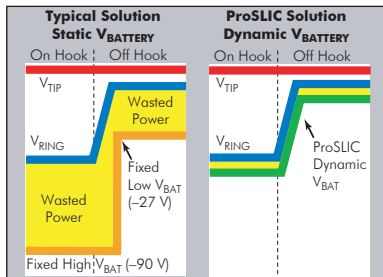

Flexible

The ProSLIC's highly programmable feature set provides the flexibility to optimize performance across a wide range of customer premise applications. All SLIC and codec parameters are 100% configurable using software programmable registers.

Global

The Si3216 and Si3215 contain all the features and flexibility needed for one hardware design to ship worldwide, including expanded coverage of Asian countries.

Enhanced Voice Quality—Smallest Footprint

The Si3216's unique integration of a complete analog wideband telephony interface enables flexible channel scalability without sacrificing cost or channel density.

(Actual Size)
1.5 in²

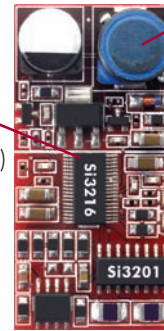

Si3216 ProSLIC

- Dual-mode wideband (50 Hz to 7 kHz)/ narrowband (200 Hz to 3.4 kHz) codec
- Integrates SLIC, codec, and battery generation
- 90 V_{PK} 5 REN internal ringing
- Globally compliant, including line impedances for China and Japan
- 38-pin TSSOP

Integrated Battery Supply

- 3.3 V to 35 V DC input range
- Dynamic 0 V to -94.5 V output
- Real time adaptive voltage output minimizes power
- Supports low cost inductor and high-efficiency transformer versions

Si3201 Linefeed Interface Chip

- Supports operation up to 100 V
- Power-enhanced 16-pin SOIC
- Fully discrete solution also supported

ProSLIC Family Feature Summary

Feature	Si3216	Si3210/ Si3211/ Si3215	Si3220	Si3225	Si3232
Number of Channels	single	single	dual	dual	dual
Integrated SLIC and Codec	✓	✓	✓	✓	no codecs
On-Chip DC/DC Converter	✓	Si3210/15			
Wideband Audio Mode	✓				✓*
Internal Ringing	90 V _{PK}	90 V _{PK}	95 V _{PK}	–	95 V _{PK}
External Ringing Support				✓	
Linefeed Device	Si3201	Si3201	Si3200	Si3200	Si3200
On-Chip DTMF Decoder		Si3210/11	✓	✓	
Subscriber Line Diagnostics	DC	DC	audio, DC	audio, DC	DC

* Using an external wideband codec.

CONTACT INFORMATION



SILICON LABORATORIES

Silicon Laboratories Inc.

4635 Boston Lane • Austin, TX 78735

Toll Free: (877) 444-3032

Email: ProSLICinfo@silabs.com

Web site: www.silabs.com

ProSLIC, Silicon Laboratories and the Silicon Laboratories logo are trademarks of Silicon Laboratories Inc.

W, 5000, September 02, Rev A

ORDERING INFORMATION

Product	Description	Evaluation Board
Si3216-KT	Wideband ProSLIC w/inductor-based DC-DC converter	Si3216PPT1-EVB
Si3216M-KT	Wideband ProSLIC w/transformer-based DC-DC converter	Si3216MPPT1-EVB
Si3215-KT	ProSLIC w/inductor-based DC-DC converter	Si3215PPT1-EVB
Si3215M-KT	ProSLIC w/transformer-based DC-DC converter	Si3215MPPT1-EVB
Si3210-KT	ProSLIC w/inductor-based DC-DC converter and DTMF decoding	Si3210PPT1-EVB
Si3210M-KT	ProSLIC w/transformer-based DC-DC converter and DTMF decoding	Si3210MPPT1-EVB
Si3211-KT	ProSLIC w/DTMF decoding	Si3211PPTX-EVB
Si3212-KT	ProSLIC	Si3212PPTX-EVB
Si3201-KS	ProSLIC linefeed interface chip for Si321x	

Standard temperature "K" grade (0 to 70 °C) part numbers shown; extended temperature "B" grade (-40 to 85 °C) also available