

USB Microcontrollers

INTEGRATED USB 2.0 FUNCTION CONTROLLER

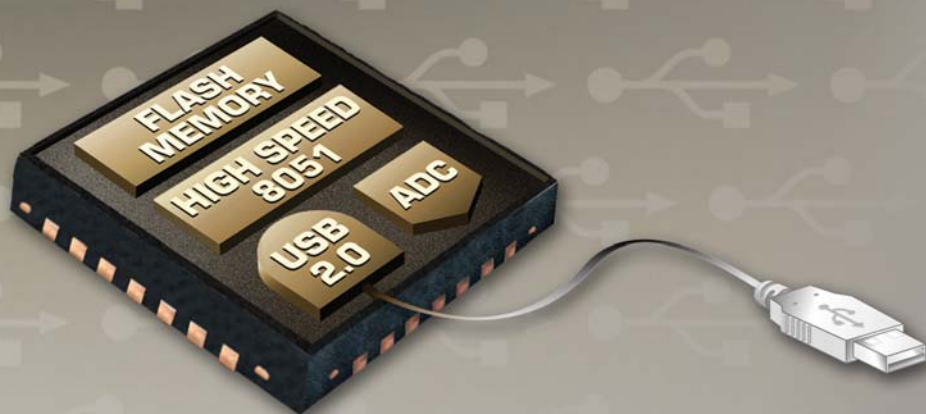

DESCRIPTION

The USB microcontroller family features an on-board universal serial bus (USB) 2.0 function controller with an integrated transceiver and on-chip clock recovery. No external resistors, crystal, voltage regulator, EEPROM or other components are required. On-chip resources include a high-speed 8051 CPU with up to 64 kB Flash, UARTs, I²C, SPI, timers, counters and PWM generators. On-chip analog features include a multi-channel 10-bit ADC, precision voltage reference, internal oscillator, comparators and a temperature sensor. Available in 28-pin QFN, 32-pin LQFP or 48-pin TQFP packages, these devices provide a single-chip solution for embedded USB applications.

USB BLOCK DIAGRAM

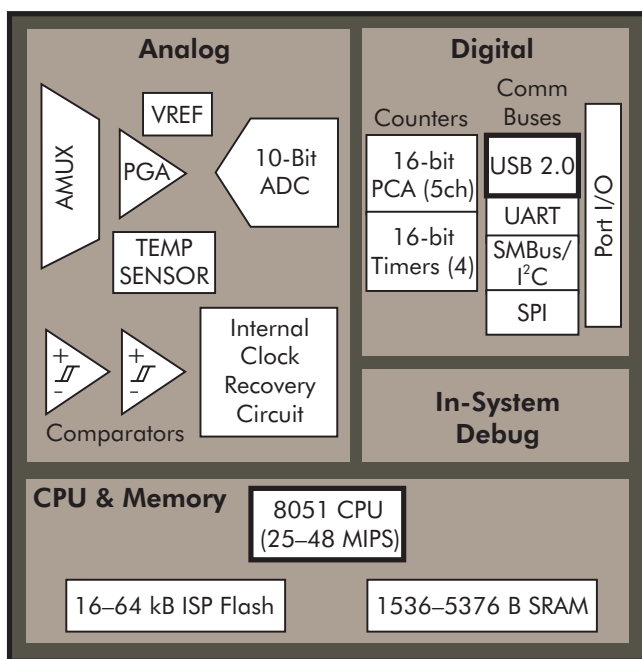

FEATURES

- USB 2.0
 - Integrated transceiver
 - Integrated clock recovery
 - 1 kB buffer RAM
 - Full (12 Mbps) or low-speed operation
 - Control endpoint plus six bi-directional endpoint pipes
- 25-48 MIPS 8051 CPU
- 16-64 kB Flash Memory
- 1536-5376 B RAM
- 10-bit, 200 ksps ADC
- Two asynchronous comparators
- Precision voltage reference
- Temperature sensor
- 15-40 digital I/O
- Packages (Pb-free, RoHS compliant)
 - QFN28
 - LQFP32
 - TQFP48



APPLICATIONS

- PC peripherals
- Point-of-sale terminals
- Consumer medical devices
- PC-based lab instrumentation
- USB modems
- Game controllers
- IP telephones
- Upgrade legacy RS-232 to USB
- Personal navigation devices

ACTUAL SIZE



SOLUTIONS GUIDE

**SINGLE-CHIP
SOLUTION FOR EMBEDDED
USB APPLICATIONS**



USB Microcontrollers

**INTEGRATED. SMALL SIZE.
WORLD-CLASS TOOLS.**

Integrated USB 2.0 Interface

These compact MCUs uniquely combine a USB 2.0 function controller with on-board clock extraction eliminating resistors, crystal, voltage regulator, EEPROM and other external components required in competing solutions. This high level of integration results in small package sizes, saving board space and reducing overall system cost.

Analog Peripherals

The USB MCUs include 10-bit ADCs with programmable throughput up to 200 ksp/s, ± 1 LSB INL with no missing codes. These ADCs also feature up to 17 external inputs that can be programmed to operate in single-ended or differential mode. Other analog peripherals include two comparators, built-in temperature sensor and internal precision voltage reference.

Development Tools

Silicon Laboratories' low-cost development kits provide all the hardware and software needed to design almost any circuit application. Standard contents include a USB to serial debugging adapter, Integrated Development Environment (IDE) CD, prototyping target PCB, USB cable and a universal power supply.

In-System Debug

All USB MCUs include on-chip 2-wire debug circuitry that provides non-intrusive, full-speed, in-circuit debugging of the production part installed in the user's end application. Emulators are never required.

USB Microcontroller Product Matrix

Part Number	Flash Memory	MIPS (peak)	RAM (bytes)	Ext Mem I/F	Digital Port I/O Pins	Serial Buses	Timers (16-bit)	PCA Chnls	Internal Osc	ADC	Temp Sensor	VREF	Comp.	Other	Package	Eval Kit
C8051F340	64 kB	48	5376	Y	40	USB 2.0, 2 x UART, SMBus, SPI	4	5	$\pm 1.5\%$	10-bit, 17-ch., 200 ksp/s	Y	Y	2	-	TQFP48	C8051F340DK
C8051F341	32 kB	48	3328	Y	40	USB 2.0, 2 x UART, SMBus, SPI	4	5	$\pm 1.5\%$	10-bit, 17-ch., 200 ksp/s	Y	Y	2	-	TQFP48	C8051F340DK
C8051F342	64 kB	48	5376	-	25	USB 2.0, UART, SMBus, SPI	4	5	$\pm 1.5\%$	10-bit, 17-ch., 200 ksp/s	Y	Y	2	-	LQFP32	C8051F340DK
C8051F343	32 kB	48	3328	-	25	USB 2.0, UART, SMBus, SPI	4	5	$\pm 1.5\%$	10-bit, 17-ch., 200 ksp/s	Y	Y	2	-	LQFP32	C8051F340DK
C8051F344	64 kB	25	5376	Y	40	USB 2.0, 2 x UART, SMBus, SPI	4	5	$\pm 1.5\%$	10-bit, 17-ch., 200 ksp/s	Y	Y	2	-	TQFP48	C8051F340DK
C8051F345	32 kB	25	3328	Y	40	USB 2.0, 2 x UART, SMBus, SPI	4	5	$\pm 1.5\%$	10-bit, 17-ch., 200 ksp/s	Y	Y	2	-	TQFP48	C8051F340DK
C8051F346	64 kB	25	5376	-	25	USB 2.0, UART, SMBus, SPI	4	5	$\pm 1.5\%$	10-bit, 17-ch., 200 ksp/s	Y	Y	2	-	LQFP32	C8051F340DK
C8051F347	32 kB	25	3328	-	25	USB 2.0, UART, SMBus, SPI	4	5	$\pm 1.5\%$	10-bit, 17-ch., 200 ksp/s	Y	Y	2	-	LQFP32	C8051F340DK
C8051F326	16 kB	25	1536	-	15	USB 2.0, UART	2	-	$\pm 1.5\%$	-	-	-	-	Separate I/O Supply Pin	QFN28	C8051F326DK
C8051F327	16 kB	25	1536	-	15	USB 2.0, UART	2	-	$\pm 1.5\%$	-	-	-	-	Fixed I/O Supply Pin	QFN28	C8051F326DK
C8051F320	16 kB	25	2304	-	25	USB 2.0, UART, SMBus, SPI	4	5	$\pm 1.5\%$	10-bit, 17-ch., 200 ksp/s	Y	Y	2	-	LQFP32	C8051F320DK
C8051F321	16 kB	25	2304	-	21	USB 2.0, UART, SMBus, SPI	4	5	$\pm 1.5\%$	10-bit, 13-ch., 200 ksp/s	Y	Y	2	-	QFN28	C8051F320DK
CP2102	1 kB	-	1024	-	-	USB to UART Bridge	-	-	Y	-	-	-	-	Volt Reg	QFN28	CP2102EK
CP2103	1 kB	-	1024	-	4	USB to UART Bridge	-	-	Y	-	-	-	-	RS485	QFN28	CP2103EK

USBXpress® Development Software

With Silicon Laboratories' USBXpress Development Software, interfacing your design to the USB has never been easier. The comprehensive kit provides a complete host and device software solution, including Microsoft Windows device drivers. No USB protocol or hardware expertise is required. Instead, a simple, high-level application program interface (API) is used on both the host and USB MCU to achieve high-performance USB connectivity.

The USBXpress Development Software includes royalty-free, Microsoft-certified device drivers, INF driver installation files, host API library and MCU API library. Microsoft Windows 2000, XP, Vista and WinCE (4.2, 5.0 and 6.0)* are supported.

*Please see Silicon Labs' USBXpress webpage for supported platforms.

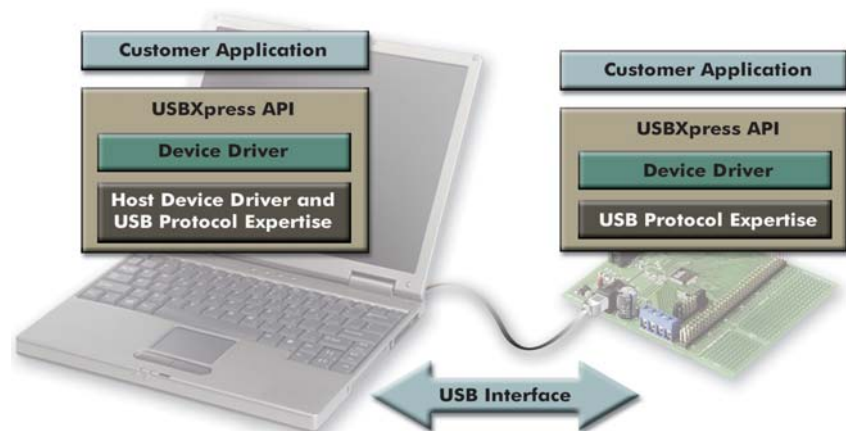

Silicon Laboratories Inc.
400 West Cesar Chavez • Austin, TX 78701
Toll Free: (877) 444-3032
Email: MCUInfo@silabs.com
Web site: www.silabs.com

