



Smart Metering Brings Intelligence and Connectivity to Utilities, Green Energy and Natural Resource Management

As green energy management becomes a global imperative, the idea of implementing intelligent systems and wireless technology to more efficiently use energy and other natural resources has become a pervasive reality. It began with a relatively simple idea. If you add embedded intelligence and a communications link to a traditional metering device, you have the ability to remotely access the data that the “smart meter” has collected. The first and most obvious application of this technology was to streamline the meter reading and billing process. However, through this seemingly simple enhancement of a communications link, a network was born, and with it came an explosion of applications and innovations transforming the way energy is measured, priced and consumed.

Multiple forms of energy are monitored and controlled in the energy metering ecosystem, including gas, water, electricity and thermal energy. Metering information from a group of residential, commercial and industrial facilities is typically sampled at regular intervals and aggregated by a common metering collector before being sent to the service provider. While the ability to automatically read meters provides compelling advantages, utilities today are implementing two-way networks that further allow individuals and businesses to make more efficient use of the energy they consume. In-home energy displays, thermostats and load controllers are emerging tools in the marketplace that enable this improved level of control. Operators equally enjoy the benefits of two-way networking due to the improved reliability and dynamic billing opportunities that it provides.

Primary utility meter types

In the very broadest sense, there are three distinct categories of metering devices. The most common is the electricity meter, which quantifies the consumption of electrical energy. The second most common is a meter that measures the consumption of a fluid, such as water, natural gas, or fuel oil. The third category of meters quantifies the consumption of thermal energy, commonly referred to as heat meters or heat cost allocators.

With respect to electricity meters, functionality can be split into two functional areas: the metrology or measurement function and the communications subsystem. The requirements for the metrology function vary by region and meter type (residential versus industrial), with some of the variables including the number of phases being measured, the accuracy of the measurement, the requirement for different rates dependent on time of use and the level of security (including encryption) required at the communication layer. In general, these systems measure the electrical power consumed by a customer, the power factor of the load and the time of electricity consumption to support multi-rate metering. These measurements rely on various sensor technologies that match the number of electrical phases in the system. Consumer meters are typically single phase, whereas commercial and industrial customers might have multiphase meters. These meters usually derive power from the mains but require an alternate supply, such as a battery or supercapacitor to maintain a state in disconnect or disruption of service condition.

Gas and water meters (see Figure 1) are generally battery-powered and consist of an embedded controller that interfaces to a metering sensor, display and communications block, typically a wireless transmitter or transceiver. They often use positive displacement flow meters to measure the number of times a unit volume of the fluid moves through the meter. For more viscous fluids, volume is measured by

a magnet or shaft that rotates. Each revolution is converted to an electrical signal and accumulated by an embedded controller. Less viscous fluids such as natural gas might rely on ultrasonic transducers to measure mass flow. Regardless of the material that is measured, low power consumption is a critical design parameter in these systems, as electricity is generally not wired to the locations of these meters.

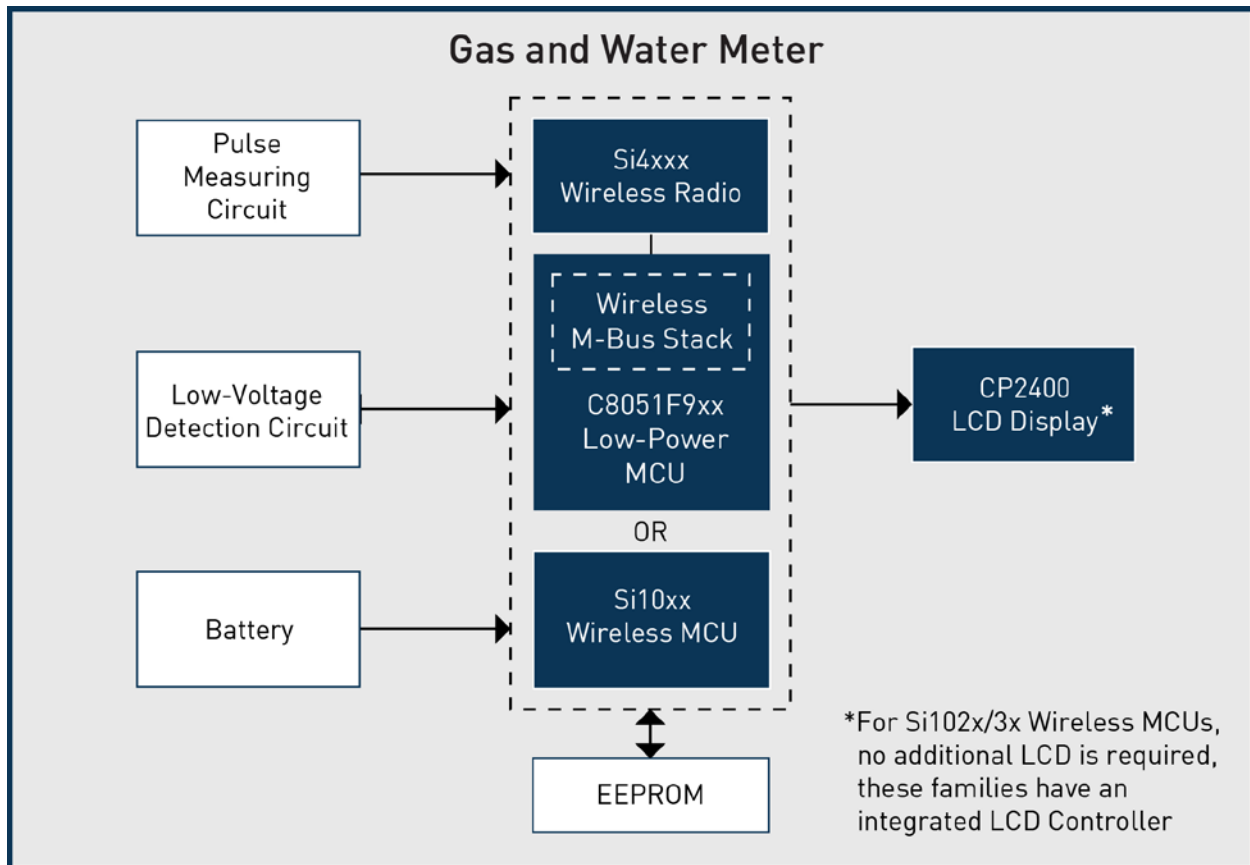

Figure 1. Smart Gas/Water Meter System Based on Silicon Labs' Wireless MCU

The third class of meters is the thermal energy meter. Heat meters and heat cost allocators are typically installed in buildings with multiple residences that rely on a centralized heating system. These meters measure the amount of heat being delivered to a location in a given period of time. Again, these are battery-operated solutions that are optimized for the lowest overall system power.

Similar in topology to gas and water meters, thermal energy meters generally have an embedded controller measuring the flow and temperature of the heating fluid and incorporate a display and communications block. Heat is billed by the power (thermal energy per unit time) delivered to the location measured by the flow of the heating fluid and the input and exit fluid temperatures over a given time period. This information is displayed for the customer on a display either integrated into the meter itself or remotely located. This information from multiple locations is transmitted over a wireless link to a collector, where it is aggregated and communicated to the service provider.

Metering functions

With those basic categories in mind, nearly every type of meter has to provide one or more of the following functions:

- **Quantitative measurement:** This varies by meter type, but the primary function of any meter is to accurately measure a quantity of something. These measurement systems span a wide range of topologies. Some examples include, but are not limited to: temperature sensors, flow sensors, shunt resistors, isolation transformers, current transformers and time-keeping systems.
- **Control and calibration:** This also varies by type of meter and is typically needed to compensate for small variations in the measurement system. These systems can also perform functions such as tamper resistance and interruption of service.
- **Communications:** This can be used to configure parameters in the meter and transfer stored data to a host via wired or wireless connection. It can also be used to update the firmware or other operational characteristics of the meter.
- **Power management:** Low power and system robustness are needed in the event of a primary source of energy going down. In nonelectric metering applications, power management is critical to minimize power consumption and maximize the battery service interval.
- **Display:** Interfaces to low-cost and low-power LCD and LED displays in seven-segment, alphanumeric, or matrix format are very common user interfaces. In many cases, there is a regulatory requirement that a customer must have the ability to view the billable quantity directly from the meter.
- **Synchronization:** Timing synchronization is critical for the reliable transmission of data to central hub or other collector systems to support functions such as data analysis and accurate billing. This is particularly needed in a wireless network that has an unpredictable or asynchronous communication protocol.

Savings from Ultra-Low Power

In some applications and markets, meters are subject to stringent low-power requirements. For example, the service interval for an underground water meter is 20 years or more. For these applications, specific lithium battery chemistries (such as lithium thionyl chloride or Li-SOCl₂) with very low self-discharge rates are needed to meet the longevity requirement. Unfortunately, these battery chemistries can be quite costly compared to their more established counterparts.

A typical “D” size Li-SOCl₂ battery has a capacity between 16 and 19 amp-hours. Even in high volume, costs of 50 cents to 75 cents per amp-hour are not unreasonable. However, when we consider the entire service life of 20 years, steady-state system currents of 10 microamps can result in dollars of battery cost for the meter provider:

10 microamps * 24 hour/day * 365 day/year * 20 years * \$0.75 amp/hour = \$1.31 in battery / system cost

Meter manufacturers frequently produce and ship millions of units per year. The high level of smart meter shipments clearly illustrates the critical importance of optimizing metering systems for the lowest power consumption.

Applying Embedded Intelligence to the Solution

When we review the different meter categories and overlay them on the metering functions, a set of core capabilities and technologies surface as key building blocks for designers of these systems. The key to any embedded intelligent system is a microcontroller (MCU). In these applications, the MCU should have very low-power requirements as well as integrating features such as a real-time clock, analog-to-digital converter and communications interface. More advanced features such as integrated LCD controllers, a cyclic redundancy check block, or an encryption engine can reduce the processing burden of the MCU and enable it to reside in low-power modes for longer periods of time, ultimately reducing the overall system power consumption.

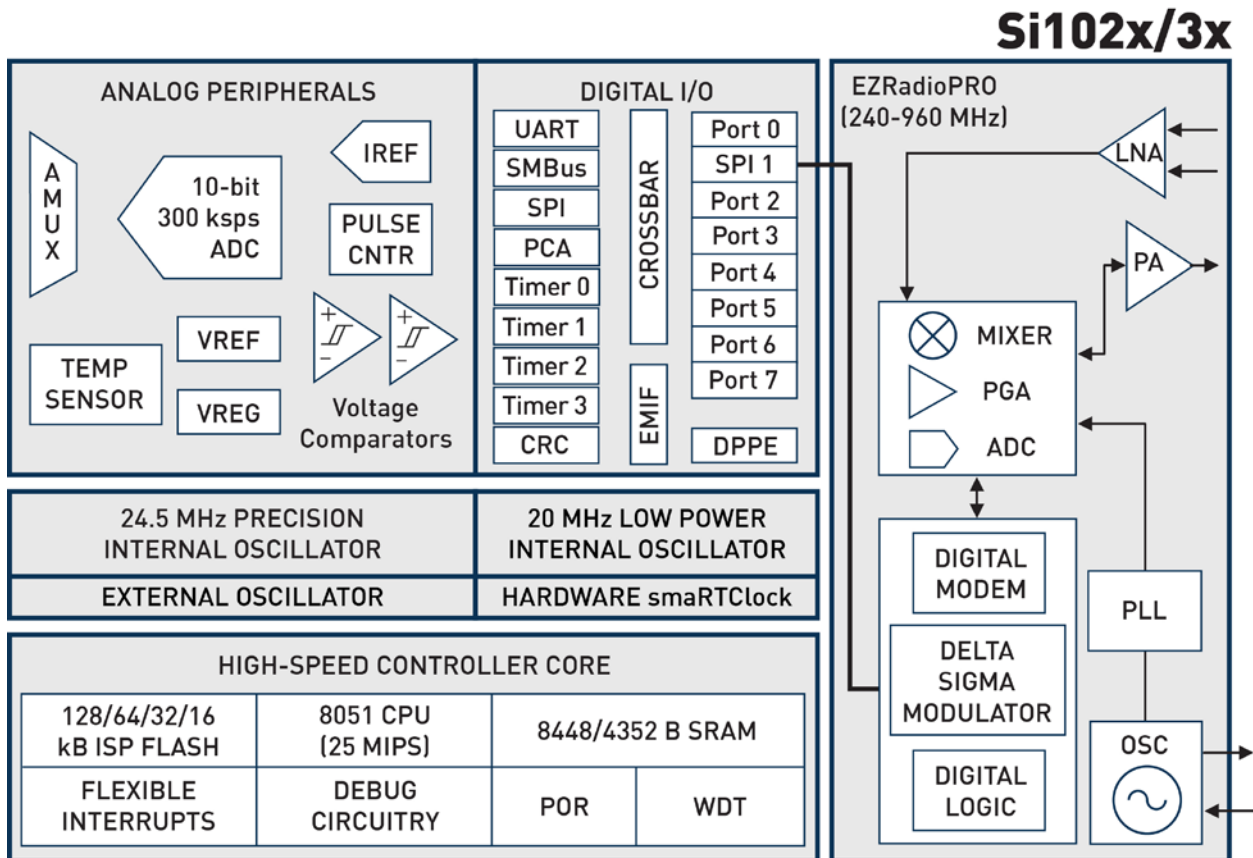

Figure 2. Si10xx Wireless MCUs Provide a Highly Integrated Control and Connectivity Solution

Wireless transmitters, receivers and transceivers are becoming more common in these systems. Key features include high levels of integration, very low power operation, fast start-up from low-power states, high receiver sensitivity (greater than -118 dBm) and high transmit powers without external power amplifiers (up to 20 dBm). More advanced features include automatic packet handling, integrated FIFO and variable frequency and modulation schemes.

Wireless MCUs (see Figure 2) that combine the microcontroller function with a wireless transceiver are also available for use in smart meter applications. These highly integrated single-chip devices can help reduce BOM and system cost while providing a low-power embedded control solution capable of high-performance wireless connectivity.

Other technologies key to these next-generation metering systems include wired access products such as modems for line-based data communication, timing solutions for network synchronization and isolation products for safety and compliance of electrical meters.

As more embedded intelligence becomes integrated into utility meters, there is no doubt there will be a growth of applications and additional opportunities to harness the energy and resource-saving capabilities these smart metering systems will bring.