

### Description

Silicon Laboratories' Si4012 is a fully integrated crystal-less CMOS high-data rate RF transmitter designed for the sub-GHz ISM band. This chip is optimized for battery powered applications requiring low standby currents and high output transmit power.

The device offers advanced radio features including continuous frequency coverage from 27–960 MHz, adjustable output power of up to +10 dBm, and data rates up to 100 Kbaud in FSK mode. The Si4012's high level of integration offers reduced BOM cost while simplifying the overall system design.

The transmitter supports data streaming into the TX FIFO without external MCU support. The digital transmit modulation and automatic PA power ramping ensure precise transmit modulation and reduced spectral splatter, ensuring compliance with FCC, ETSI, and ARIB regulations. Additional system features such as the low battery detector and 256 byte TX FIFO reduce overall current consumption and allow the use of lower-cost system MCUs. The Si4012 is optimized for wireless MBUS T1-mode.

The device leverages Silicon Labs' patented and proven crystal-less oscillator technology and offers better than  $\pm 150$  ppm carrier frequency stability over the temperature range of 0 to +70 °C and  $\pm 250$  ppm carrier frequency stability over the industrial range of -40 to +85 °C without the use of an external crystal or frequency reference. The Si4012 automatically calibrates the on-chip voltage controlled oscillator (LCOSC) which forms the output carrier frequency for process and temperature variations. An external 1-pin crystal oscillator option is available for applications requiring tighter frequency tolerances. The Si4012 is designed to work with an MCU and a few passives to create a very low-cost system. Voltage regulators are integrated on-chip, which allows for a wide range of operating supply voltage conditions from +1.8 to +3.6 V. Digital integration reduces the amount of required external components compared to traditional offerings. The high integration of the Si4012 improves the system manufacturing reliability, quality, and minimizes costs. This chip offers industry leading RF performance, high integration, flexibility, low BOM, small board area, and ease of design. No production alignment is necessary as all RF functions are integrated into the device.

### Features

- Frequency Range = 27–960 MHz
- FSK and OOK modulation
- Output Power
  - Maximum: +10 dBm
  - Configurable: -13 to +10 dBm
- Crystal-less operation
  - $\pm 150$  ppm: 0 to +70 °C
  - $\pm 250$  ppm: -40 to +85 °C
  - Optional crystal input for tighter tolerances
- Data Rate
  - FSK: 0.1 to 100 Kbaud
  - OOK: 0.1 to 20 Kbaud
- Power Supply = 1.8 to 3.6 V
- TX 256 byte FIFO
- Low battery detector
- SMBus interface
- -40 to +85 °C temperature range
- 10-pin MSOP, Pb free/RoHS compliant

### Applications

- Remote meter reading
- Wireless MBUS T1-mode
- Remote control
- Remote keyless entry
- Home security and alarm
- Telemetry
- Toy control
- Home automation
- Industrial control
- Sensor networks
- Health monitors

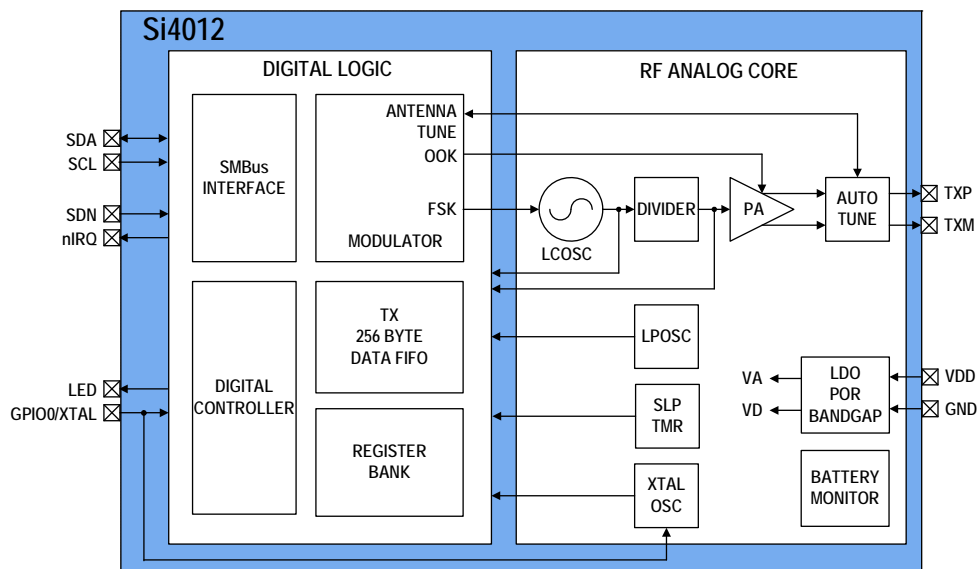

### Selected Electrical Specifications

Parameter	Symbol	Test Condition	Min	Typ	Max	Unit
Supply Voltage Range	$V_{DD}$		1.8	—	3.6	V
Power Saving Modes	$I_{Shutdown}$	Lowest current mode	—	100	—	nA
	$I_{Idle}$	Register values retained, lowest current consumption idle mode	—	700	—	nA
	$I_{Tune}$	Register values retained, LCOSC on, fastest response to TX mode	—	5	—	mA
TX Mode Current @ +10 dBm	$I_{TX\_OOK}$	OOK, Manchester encoded	—	14.2	—	mA
	$I_{TX\_FSK}$	FSK	—	19.8	—	mA
Mode Response Time to TX	$t_{Shutdown-TX}$		—	21.4	—	ms
	$t_{Shutdown-Idle}$		—	16.4	—	ms
	$t_{Idle-TX}$		—	5	—	ms
	$t_{Tune-TX}$		—	100	—	us
Frequency Range	$F_{Range}$		27	—	960	MHz
Carrier Frequency Accuracy		0 to + 70 °C	-150	—	+150	ppm
		-40 to + 85 °C	-250	—	+250	ppm
		Error contribution using optional crystal	-10	—	+10	ppm
Frequency Noise (rms)		Allen deviation, measured across 1ms interval	—	0.3	—	ppm
Frequency Tuning Time			—	5	—	ms
FSK Modulation Data Rate	$DR_{FSK}$		0.1	—	100	Kbaud
OOK Modulation Data Rate	$DR_{OOK}$		0.1	—	50	Kbaud
Transmit Power		Configurable output power range with optimum load and $V_{DD} > 2.2$ V	-13	—	+10	dBm
		Power variation vs temp and supply, with optimum load and $V_{DD} > 2.2$ V	-1.0	—	+0.5	dB
		Power variation vs temp and supply, with optimum load and $V_{DD} > 1.8$ V	-2.5	—	+0.5	dB
		Step size from -13 to +6.5 dBm with optimum load and $V_{DD} > 2.2$ V	—	0.25	—	dB
FSK Deviation			—	300	—	ppm
Operating Ambient Temperature Range	$T_A$		-40	—	85	°C

### MSOP-10 Pin Package

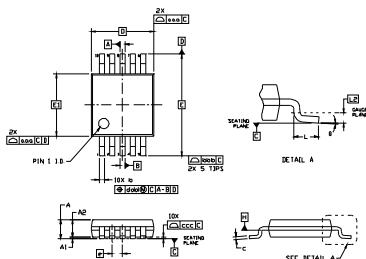
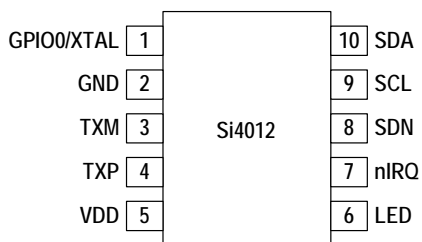

Symbol	Min	Nom	Max
A	—	—	1.10
A1	0.00	—	0.15
A2	0.75	0.85	0.95
b	0.17	—	0.33
c	0.08	—	0.23
D	3.00 BSC		
E	4.90 BSC		
E1	3.00 BSC		

Symbol	Min	Nom	Max
e	0.50 BSC		
L	0.40	0.60	0.80
L2	0.25 BSC		
q	0°	—	8°
aaa	—	—	0.20
bbb	—	—	0.25
ccc	—	—	0.10
ddd	—	—	0.08

#### Notes:

1. All dimensions are shown in millimeters (mm).
2. Dimensioning and tolerancing per ASME Y14.5M-1994.
3. This drawing conforms to JEDEC Outline MS012, variation "BA."
4. Recommended card reflow profile is per the JEDEC/IPC J-STD-020 specification for Small Body Components.