

## ANY FREQUENCY PRECISION CLOCK MULTIPLIER/JITTER ATTENUATOR

### Features

- Generates any frequency from 2 kHz to 945 MHz and select frequencies to 1.4 GHz from an input frequency of 2 kHz to 710 MHz
- Ultra-low jitter clock outputs with jitter generation as low as 0.3 ps rms (50 kHz–80 MHz)
- Integrated loop filter with selectable loop bandwidth (60 Hz to 8.4 kHz)
- Meets OC-192 GR-253-CORE jitter specifications
- Dual clock inputs with manual or automatically controlled hitless switching (LVPECL, LVDS, CML, CMOS)
- Dual clock outputs with selectable signal format
- Support for ITU G.709 and custom FEC ratios (255/238, 255/237, 255/236)
- LOL, LOS, FOS alarm outputs
- Digitally-controlled output phase adjustment
- I<sup>2</sup>C or SPI programmable
- On-chip voltage regulator for 1.8 ±5%, 2.5 ±10%, or 3.3 V ±10% operation
- Small size: 6 x 6 mm 36-lead QFN
- Pb-free, ROHS compliant



### Applications

- SONET/SDH OC-48/OC-192/STM-16/STM-64 line cards
- ITU G.709 and custom FEC line cards
- GbE/10GbE, 1/2/4/8/10G Fibre Channel line cards
- GbE/10GbE Synchronous Ethernet
- Optical modules
- Wireless basestations
- Data converter clocking
- xDSL
- PDH clock synthesis
- Test and measurement
- Broadcast video

### Description

The Si5326 is a jitter-attenuating precision clock multiplier for applications requiring sub 1 ps jitter performance. The Si5326 accepts two input clocks ranging from 2 kHz to 710 MHz and generates two output clocks ranging from 2 kHz to 945 MHz and select frequencies to 1.4 GHz. The two outputs are divided down separately from a common source. The Si5326 can also use its crystal oscillator as a clock source for frequency synthesis. The Si5326 input clock frequency and clock multiplication ratio are programmable through an I<sup>2</sup>C or SPI interface. The Si5326 is based on Silicon Laboratories' 3rd-generation DSPLL<sup>®</sup> technology, which provides frequency synthesis and jitter attenuation in a highly integrated PLL solution that eliminates the need for external VCXO and loop filter components. The DSPLL loop bandwidth is digitally programmable, providing jitter performance optimization at the application level. Operating from a single 1.8, 2.5, or 3.3 V supply, the Si5326 is ideal for providing clock multiplication and jitter attenuation in high performance timing applications.

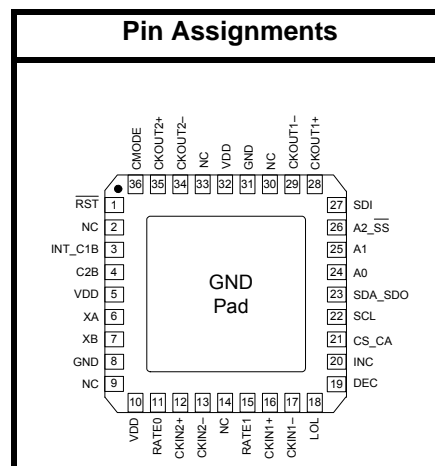

# Si5326

## Functional Block Diagram

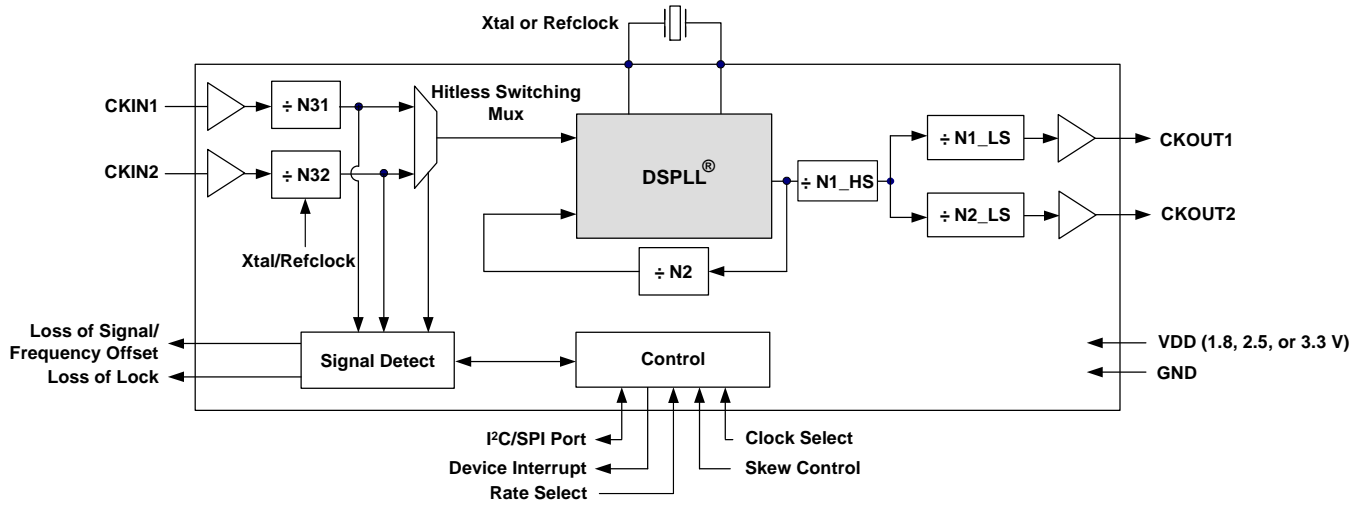

---

**TABLE OF CONTENTS**

---

<b>1. Electrical Specifications</b>	<b>4</b>
<b>2. Typical Phase Noise Performance</b>	<b>16</b>
<b>3. Typical Application Circuit</b>	<b>17</b>
<b>4. Functional Description</b>	<b>18</b>
4.1. External Reference	19
4.2. Further Documentation	19
<b>5. Register Map</b>	<b>20</b>
<b>6. Register Descriptions</b>	<b>22</b>
<b>7. Pin Descriptions: Si5326</b>	<b>58</b>
<b>8. Ordering Guide</b>	<b>65</b>
<b>9. Package Outline: 36-Pin QFN</b>	<b>66</b>
<b>10. Recommended PCB Layout</b>	<b>67</b>
<b>11. Si5326 Device Top Mark</b>	<b>69</b>
<b>Document Change List</b>	<b>70</b>
<b>Contact Information</b>	<b>72</b>

## 1. Electrical Specifications

**Table 1. Recommended Operating Conditions**

Parameter	Symbol	Test Condition	Min	Typ	Max	Unit
Ambient Temperature	$T_A$		-40	25	85	C
Supply Voltage during Normal Operation	$V_{DD}$	3.3 V Nominal	2.97	3.3	3.63	V
		2.5 V Nominal	2.25	2.5	2.75	V
		1.8 V Nominal	1.71	1.8	1.89	V

**Note:** All minimum and maximum specifications are guaranteed and apply across the recommended operating conditions. Typical values apply at nominal supply voltages and an operating temperature of 25 °C unless otherwise stated.

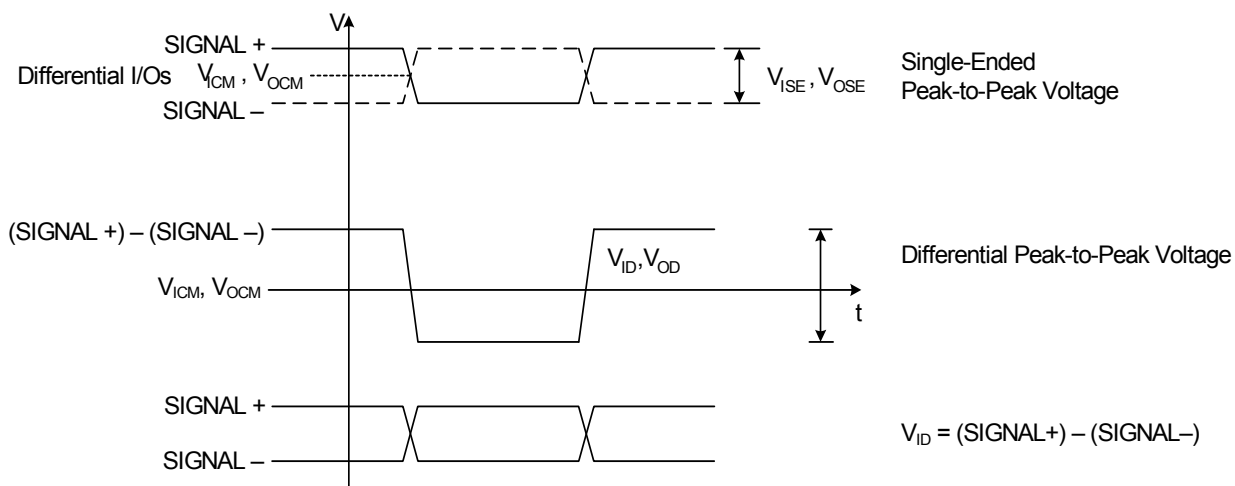

**Figure 1. Differential Voltage Characteristics**

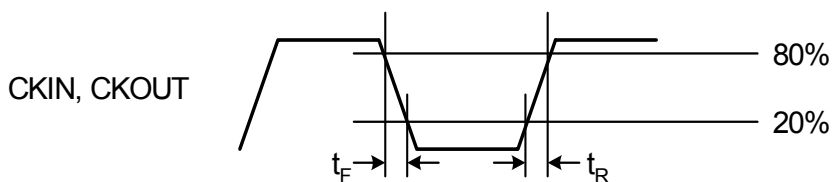

**Figure 2. Rise/Fall Time Characteristics**

**Table 2. DC Characteristics** $(V_{DD} = 1.8 \pm 5\%, 2.5 \pm 10\%, \text{ or } 3.3 \text{ V} \pm 10\%, T_A = -40 \text{ to } 85 \text{ }^\circ\text{C})$ 

Parameter	Symbol	Test Condition	Min	Typ	Max	Unit
Supply Current <sup>1</sup>	$I_{DD}$	LVPECL Format 622.08 MHz Out Both CKOUTs Enabled	—	251	279	mA
		LVPECL Format 622.08 MHz Out 1 CKOUT Enabled	—	217	243	mA
		CMOS Format 19.44 MHz Out Both CKOUTs Enabled	—	204	234	mA
		CMOS Format 19.44 MHz Out 1 CKOUT Enabled	—	194	220	mA
		Disable Mode	—	165	—	mA
<b>CKINn Input Pins<sup>2</sup></b>						
Input Common Mode Voltage (Input Threshold Voltage)	$V_{ICM}$	1.8 V $\pm$ 5%	0.9	—	1.4	V
		2.5 V $\pm$ 10%	1	—	1.7	V
		3.3 V $\pm$ 10%	1.1	—	1.95	V
Input Resistance	$CKN_{RIN}$	Single-ended	20	40	60	k $\Omega$
Single-Ended Input Voltage Swing (See Absolute Specs)	$V_{ISE}$	$f_{CKIN} < 212.5 \text{ MHz}$ See Figure 1.	0.2	—	—	$V_{PP}$
		$f_{CKIN} > 212.5 \text{ MHz}$ See Figure 1.	0.25	—	—	$V_{PP}$
Differential Input Voltage Swing (See Absolute Specs)	$V_{ID}$	$f_{CKIN} < 212.5 \text{ MHz}$ See Figure 1.	0.2	—	—	$V_{PP}$
		$f_{CKIN} > 212.5 \text{ MHz}$ See Figure 1.	0.25	—	—	$V_{PP}$
<b>Output Clocks (CKOUTn)<sup>3</sup></b>						
Common Mode	$CKO_{VCM}$	LVPECL 100 $\Omega$ load line-to-line	$V_{DD} - 1.42$	—	$V_{DD} - 1.25$	V
<b>Notes:</b>						
1. Current draw is independent of supply voltage						
2. No under- or overshoot is allowed.						
3. LVPECL outputs require nominal $V_{DD} \geq 2.5 \text{ V}$ .						
4. This is the amount of leakage that the 3-Level inputs can tolerate from an external driver. See Si53xx Family Reference Manual for more details.						
5. LVPECL, CML, LVDS and low-swing LVDS measured with $F_o = 622.08 \text{ MHz}$ .						

**Table 2. DC Characteristics (Continued)** $(V_{DD} = 1.8 \pm 5\%, 2.5 \pm 10\%, \text{ or } 3.3 \text{ V} \pm 10\%, T_A = -40 \text{ to } 85 \text{ }^\circ\text{C})$ 

Parameter	Symbol	Test Condition	Min	Typ	Max	Unit
Differential Output Swing	$CKO_{VD}$	LVPECL 100 $\Omega$ load line-to-line	1.1	—	1.9	$V_{PP}$
Single Ended Output Swing	$CKO_{VSE}$	LVPECL 100 $\Omega$ load line-to-line	0.5	—	0.93	$V_{PP}$
Differential Output Voltage	$CKO_{VD}$	CML 100 $\Omega$ load line-to-line	350	425	500	$mV_{PP}$
Common Mode Output Voltage	$CKO_{VCM}$	CML 100 $\Omega$ load line-to-line	—	$V_{DD}-0.36$	—	V
Differential Output Voltage	$CKO_{VD}$	LVDS 100 $\Omega$ load line-to-line	500	700	900	$mV_{PP}$
		Low Swing LVDS 100 $\Omega$ load line-to-line	350	425	500	$mV_{PP}$
Common Mode Output Voltage	$CKO_{VCM}$	LVDS 100 $\Omega$ load line-to-line	1.125	1.2	1.275	V
Differential Output Resistance	$CKO_{RD}$	CML, LVPECL, LVDS	—	200	—	$\Omega$
Output Voltage Low	$CKO_{VOLLH}$	CMOS	—	—	0.4	V
Output Voltage High	$CKO_{VOHLH}$	$V_{DD} = 1.71 \text{ V}$ CMOS	$0.8 \times V_{DD}$	—	—	V

**Notes:**

1. Current draw is independent of supply voltage
2. No under- or overshoot is allowed.
3. LVPECL outputs require nominal  $V_{DD} \geq 2.5 \text{ V}$ .
4. This is the amount of leakage that the 3-Level inputs can tolerate from an external driver. See Si53xx Family Reference Manual for more details.
5. LVPECL, CML, LVDS and low-swing LVDS measured with  $F_o = 622.08 \text{ MHz}$ .

**Table 2. DC Characteristics (Continued)** $(V_{DD} = 1.8 \pm 5\%, 2.5 \pm 10\%, \text{ or } 3.3 \text{ V} \pm 10\%, T_A = -40 \text{ to } 85 \text{ }^\circ\text{C})$ 

Parameter	Symbol	Test Condition	Min	Typ	Max	Unit
Output Drive Current (CMOS driving into CKO <sub>VOL</sub> for output low or CKO <sub>VOH</sub> for output high. CKOUT+ and CKOUT– shorted externally)	CKO <sub>IO</sub>	ICMOS[1:0] =11 $V_{DD} = 1.8 \text{ V}$	—	7.5	—	mA
		ICMOS[1:0] =10 $V_{DD} = 1.8 \text{ V}$	—	5.5	—	mA
		ICMOS[1:0] =01 $V_{DD} = 1.8 \text{ V}$	—	3.5	—	mA
		ICMOS[1:0] =00 $V_{DD} = 1.8 \text{ V}$	—	1.75	—	mA
		ICMOS[1:0] =11 $V_{DD} = 3.3 \text{ V}$	—	32	—	mA
		ICMOS[1:0] =10 $V_{DD} = 3.3 \text{ V}$	—	24	—	mA
		ICMOS[1:0] =01 $V_{DD} = 3.3 \text{ V}$	—	16	—	mA
		ICMOS[1:0] =00 $V_{DD} = 3.3 \text{ V}$	—	8	—	mA
<b>2-Level LVCMOS Input Pins</b>						
Input Voltage Low	$V_{IL}$	$V_{DD} = 1.71 \text{ V}$	—	—	0.5	V
		$V_{DD} = 2.25 \text{ V}$	—	—	0.7	V
		$V_{DD} = 2.97 \text{ V}$	—	—	0.8	V
Input Voltage High	$V_{IH}$	$V_{DD} = 1.89 \text{ V}$	1.4	—	—	V
		$V_{DD} = 2.25 \text{ V}$	1.8	—	—	V
		$V_{DD} = 3.63 \text{ V}$	2.5	—	—	V
<b>Notes:</b>						
1. Current draw is independent of supply voltage						
2. No under- or overshoot is allowed.						
3. LVPECL outputs require nominal $V_{DD} \geq 2.5 \text{ V}$ .						
4. This is the amount of leakage that the 3-Level inputs can tolerate from an external driver. See Si53xx Family Reference Manual for more details.						
5. LVPECL, CML, LVDS and low-swing LVDS measured with $F_o = 622.08 \text{ MHz}$ .						

**Table 2. DC Characteristics (Continued)**(V<sub>DD</sub> = 1.8 ± 5%, 2.5 ± 10%, or 3.3 V ± 10%, T<sub>A</sub> = -40 to 85 °C)

Parameter	Symbol	Test Condition	Min	Typ	Max	Unit
<b>3-Level Input Pins<sup>4</sup></b>						
Input Voltage Low	V <sub>ILL</sub>		—	—	0.15 x V <sub>DD</sub>	V
Input Voltage Mid	V <sub>IMM</sub>		0.45 x V <sub>DD</sub>	—	0.55 x V <sub>DD</sub>	V
Input Voltage High	V <sub>IHH</sub>		0.85 x V <sub>DD</sub>	—	—	V
Input Low Current	I <sub>ILL</sub>	See Note 4	-20	—	—	μA
Input Mid Current	I <sub>IMM</sub>	See Note 4	-2	—	+2	μA
Input High Current	I <sub>IHH</sub>	See Note 4	—	—	20	μA
<b>LVC MOS Output Pins</b>						
Output Voltage Low	V <sub>OL</sub>	IO = 2 mA V <sub>DD</sub> = 1.71 V	—	—	0.4	V
Output Voltage Low		IO = 2 mA V <sub>DD</sub> = 2.97 V	—	—	0.4	V
Output Voltage High	V <sub>OH</sub>	IO = -2 mA V <sub>DD</sub> = 1.71 V	V <sub>DD</sub> - 0.4	—	—	V
Output Voltage High		IO = -2 mA V <sub>DD</sub> = 2.97 V	V <sub>DD</sub> - 0.4	—	—	V
Disabled Leakage Current	I <sub>OZ</sub>	RSTb = 0	-100	—	100	μA
<b>Notes:</b>						
1. Current draw is independent of supply voltage						
2. No under- or overshoot is allowed.						
3. LVPECL outputs require nominal V <sub>DD</sub> ≥ 2.5 V.						
4. This is the amount of leakage that the 3-Level inputs can tolerate from an external driver. See Si53xx Family Reference Manual for more details.						
5. LVPECL, CML, LVDS and low-swing LVDS measured with Fo = 622.08 MHz.						

**Table 3. Microprocessor Control** $(V_{DD} = 1.8 \pm 5\%, 2.5 \pm 10\%, \text{ or } 3.3 \text{ V} \pm 10\%, T_A = -40 \text{ to } 85 \text{ }^\circ\text{C})$ 

Parameter	Symbol	Test Condition	Min	Typ	Max	Unit
<b>I<sup>2</sup>C Bus Lines (SDA, SCL)</b>						
Input Voltage Low	$V_{IL_{I2C}}$		—	—	$0.25 \times V_{DD}$	V
Input Voltage High	$V_{IH_{I2C}}$		$0.7 \times V_{DD}$	—	$V_{DD}$	V
Input Current	$I_{I2C}$	$V_{IN} = 0.1 \times V_{DD}$ to $0.9 \times V_{DD}$	-10	—	10	$\mu\text{A}$
Hysteresis of Schmitt trigger inputs	$V_{HYS_{I2C}}$	$V_{DD} = 1.8\text{V}$	$0.1 \times V_{DD}$	—	—	V
		$V_{DD} = 2.5 \text{ or } 3.3 \text{ V}$	$0.05 \times V_{DD}$	—	—	V
Output Voltage Low	$V_{OL_{I2C}}$	$V_{DD} = 1.8 \text{ V}$ $I_O = 3 \text{ mA}$	—	—	$0.2 \times V_{DD}$	V
		$V_{DD} = 2.5 \text{ or } 3.3 \text{ V}$ $I_O = 3 \text{ mA}$	—	—	0.4	V

**Table 3. Microprocessor Control (Continued)**

( $V_{DD} = 1.8 \pm 5\%$ ,  $2.5 \pm 10\%$ , or  $3.3 V \pm 10\%$ ,  $T_A = -40$  to  $85\text{ }^\circ\text{C}$ )

Parameter	Symbol	Test Condition	Min	Typ	Max	Unit
<b>SPI Specifications</b>						
Duty Cycle, SCLK	$t_{DC}$	SCLK = 10 MHz	40	—	60	%
Cycle Time, SCLK	$t_c$		100	—	—	ns
Rise Time, SCLK	$t_r$	20–80%	—	—	25	ns
Fall Time, SCLK	$t_f$	20–80%	—	—	25	ns
Low Time, SCLK	$t_{lsc}$	20–20%	30	—	—	ns
High Time, SCLK	$t_{hsc}$	80–80%	30	—	—	ns
Delay Time, SCLK Fall to SDO Active	$t_{d1}$		—	—	25	ns
Delay Time, SCLK Fall to SDO Transition	$t_{d2}$		—	—	25	ns
Delay Time, SS Rise to SDO Tri-state	$t_{d3}$		—	—	25	ns
Setup Time, SS to SCLK Fall	$t_{su1}$		25	—	—	ns
Hold Time, SS to SCLK Rise	$t_{h1}$		20	—	—	ns
Setup Time, SDI to SCLK Rise	$t_{su2}$		25	—	—	ns
Hold Time, SDI to SCLK Rise	$t_{h2}$		20	—	—	ns
Delay Time between Slave Selects	$t_{cs}$		25	—	—	ns

**Table 4. AC Specifications** $(V_{DD} = 1.8 \pm 5\%, 2.5 \pm 10\%, \text{ or } 3.3 \text{ V} \pm 10\%, T_A = -40 \text{ to } 85 \text{ }^\circ\text{C})$ 

Parameter	Symbol	Test Condition	Min	Typ	Max	Unit
<b>Single-Ended Reference Clock Input Pin XA (XB with cap to GND)</b>						
Input Resistance	$XA_{RIN}$	RATE[1:0] = LM, ML, MH, or HM, ac coupled	—	12	—	$k\Omega$
Input Voltage Swing	$XA_{VPP}$	RATE[1:0] = LM, ML, MH, or HM, ac coupled	0.5	—	1.2	$V_{PP}$
<b>Differential Reference Clock Input Pins (XA/XB)</b>						
Input Voltage Swing	$XA/XB_{VPP}$	RATE[1:0] = LM, ML, MH, or HM	0.5	—	1.2	$V_{PP}$ , each.
<b>CKINn Input Pins</b>						
Input Frequency	$CKN_F$		0.002	—	710	MHz
Input Duty Cycle (Minimum Pulse Width)	$CKN_{DC}$	Whichever is smaller (i.e., the 40% / 60% limitation applies only to high frequency clocks)	40	—	60	%
			2	—	—	ns
Input Capacitance	$CKN_{CIN}$		—	—	3	pF
Input Rise/Fall Time	$CKN_{TRF}$	20–80% See Figure 2	—	—	11	ns
<b>CKOUTn Output Pins</b>						
(See ordering section for speed grade vs frequency limits)						
Output Frequency (Output not configured for CMOS or Disabled)	$CKO_F$	$N1 \geq 6$	0.002	—	945	MHz
		$N1 = 5$	970	—	1134	MHz
		$N1 = 4$	1.213	—	1.4	GHz
Maximum Output Frequency in CMOS Format	$CKO_F$		—	—	212.5	MHz
Output Rise/Fall (20–80 %) @ 622.08 MHz output	$CKO_{TRF}$	Output not configured for CMOS or Disabled See Figure 2	—	230	350	ps
Output Rise/Fall (20–80%) @ 212.5 MHz output	$CKO_{TRF}$	CMOS Output $V_{DD} = 1.71$ $C_{LOAD} = 5 \text{ pF}$	—	—	8	ns

**Table 4. AC Specifications (Continued)** $(V_{DD} = 1.8 \pm 5\%, 2.5 \pm 10\%, \text{ or } 3.3 \text{ V} \pm 10\%, T_A = -40 \text{ to } 85 \text{ }^\circ\text{C})$ 

Parameter	Symbol	Test Condition	Min	Typ	Max	Unit
Output Rise/Fall (20–80%) @ 212.5 MHz output	CKO <sub>TRF</sub>	CMOS Output $V_{DD} = 2.97$ $C_{LOAD} = 5 \text{ pF}$	—	—	2	ns
Output Duty Cycle Uncertainty @ 622.08 MHz	CKO <sub>DC</sub>	100 $\Omega$ Load Line-to-Line Measured at 50% Point (Not for CMOS)	—	—	+/-40	ps
<b>LVC MOS Input Pins</b>						
Minimum Reset Pulse Width	t <sub>RSTMN</sub>		1			$\mu\text{s}$
Reset to Microprocessor Access Ready	t <sub>READY</sub>				10	ms
Input Capacitance	C <sub>in</sub>		—	—	3	pF
<b>LVC MOS Output Pins</b>						
Rise/Fall Times	t <sub>RF</sub>	$C_{LOAD} = 20\text{pF}$ See Figure 2	—	25	—	ns
LOS <sub>n</sub> Trigger Window	LOS <sub>TRIG</sub>	From last CKIN <sub>n</sub> $\uparrow$ to $\downarrow$ Internal detection of LOS <sub>n</sub> $N3 \neq 1$	—	—	4.5 x N3	T <sub>CKIN</sub>
Time to Clear LOL after LOS Cleared	t <sub>CLRLOL</sub>	$\downarrow$ LOS to $\downarrow$ LOL Fold = F <sub>new</sub> Stable Xa/XB reference	—	10	—	ms
<b>Device Skew</b>						
Output Clock Skew	t <sub>SKEW</sub>	$\uparrow$ of CKOUT <sub>n</sub> to $\uparrow$ of CKOUT <sub>m</sub> , CKOUT <sub>n</sub> and CKOUT <sub>m</sub> at same frequency and signal format PHASEOFFSET = 0 CKOUT_ALWAYS_ON = 1 SQ_ICAL = 1	—	—	100	ps
Phase Change due to Temperature Variation	t <sub>TEMP</sub>	Max phase changes from -40 to +85 $^\circ\text{C}$	—	300	500	ps

**Table 4. AC Specifications (Continued)**(V<sub>DD</sub> = 1.8 ± 5%, 2.5 ± 10%, or 3.3 V ± 10%, T<sub>A</sub> = -40 to 85 °C)

Parameter	Symbol	Test Condition	Min	Typ	Max	Unit
<b>PLL Performance</b> (f <sub>in</sub> =f <sub>out</sub> = 622.08 MHz; BW=120 Hz; LVPECL)						
Lock Time	t <sub>LOCKMP</sub>	Start of ICAL to ↓ of LOL	—	35	1200	ms
Output Clock Phase Change	t <sub>P_STEP</sub>	After clock switch f <sub>3</sub> ≥ 128 kHz	—	200	—	ps
Closed Loop Jitter Peaking	J <sub>PK</sub>		—	0.05	0.1	dB
Jitter Tolerance	J <sub>TOL</sub>	Jitter Frequency ≥ Loop Bandwidth	5000/BW	—	—	ns pk-pk
Phase Noise f <sub>out</sub> = 622.08 MHz	CKO <sub>PN</sub>	1 kHz Offset	—	-106	-87	dBc/Hz
		10 kHz Offset	—	-121	-100	dBc/Hz
		100 kHz Offset	—	-132	-104	dBc/Hz
		1 MHz Offset	—	-132	-119	dBc/Hz
Subharmonic Noise	SP <sub>SUBH</sub>	Phase Noise @ 100 kHz Offset	—	-88	-76	dBc
Spurious Noise	SP <sub>SPUR</sub>	Max spur @ n x F <sub>3</sub> (n ≥ 1, n x F <sub>3</sub> < 100 MHz)	—	-93	-70	dBc

Table 5. Jitter Generation

Parameter	Symbol	Test Condition*		Min	Typ	Max	GR-253-Specification	Unit
		Measurement Filter	DSPLL BW <sup>2</sup>					
Jitter Gen OC-192	JGEN	0.02–80 MHz	120 Hz	—	4.2	6.2	30	ps <sub>pp</sub>
				—	.27	.42	N/A	ps <sub>rms</sub>
		4–80 MHz	120 Hz	—	3.7	6.4	10	ps <sub>pp</sub>
				—	.14	0.31	N/A	ps <sub>rms</sub>
		0.05–80 MHz	120 Hz	—	4.4	6.9	10	ps <sub>pp</sub>
				—	.26	0.41	1.0	ps <sub>rms</sub>
Jitter Gen OC-48	JGEN	0.12–20 MHz	120 Hz	—	3.5	5.4	40.2	ps <sub>pp</sub>
				—	.27	0.41	4.02	ps <sub>rms</sub>

**\*Note:** Test conditions:  
1. f<sub>IN</sub> = f<sub>OUT</sub> = 622.08 MHz  
2. Clock input: LVPECL  
3. Clock output: LVPECL  
4. PLL bandwidth: 120 Hz  
5. 114.285 MHz 3rd OT crystal used as XA/XB input  
6. V<sub>DD</sub> = 2.5 V  
7. T<sub>A</sub> = 85 °C

Table 6. Thermal Characteristics

(V<sub>DD</sub> = 1.8 ±5%, 2.5 ±10%, or 3.3 V ±10%, T<sub>A</sub> = –40 to 85 °C)

Parameter	Symbol	Test Condition	Value	Unit
Thermal Resistance Junction to Ambient	θ <sub>JA</sub>	Still Air	32	C°/W
Thermal Resistance Junction to Case	θ <sub>JC</sub>	Still Air	14	C°/W

Table 7. Absolute Limits

Parameter	Symbol	Test Condition	Min	Typ	Max	Unit
DC Supply Voltage	$V_{DD}$		-0.5	—	3.8	V
LVC MOS Input Voltage	$V_{DIG}$		-0.3		$V_{DD}+0.3$	V
CKINn Voltage Level Limits	$CKN_{VIN}$		0	—	$V_{DD}$	V
XA/XB Voltage Level Limits	$XA_{VIN}$		0	—	1.2	V
Operating Junction Temperature	$T_{JCT}$		-55	—	150	°C
Storage Temperature Range	$T_{STG}$		-55	—	150	°C
ESD HBM Tolerance (100 pF, 1.5 k $\Omega$ ); All pins except CKIN+/CKIN-			2	—	—	kV
ESD MM Tolerance; All pins except CKIN+/CKIN-			150	—	—	V
ESD HBM Tolerance (100 pF, 1.5 k $\Omega$ ); CKIN+/CKIN-			750	—	—	V
ESD MM Tolerance; CKIN+/CKIN-			100	—	—	V
Latch-up Tolerance			JESD78 Compliant			

## 2. Typical Phase Noise Performance

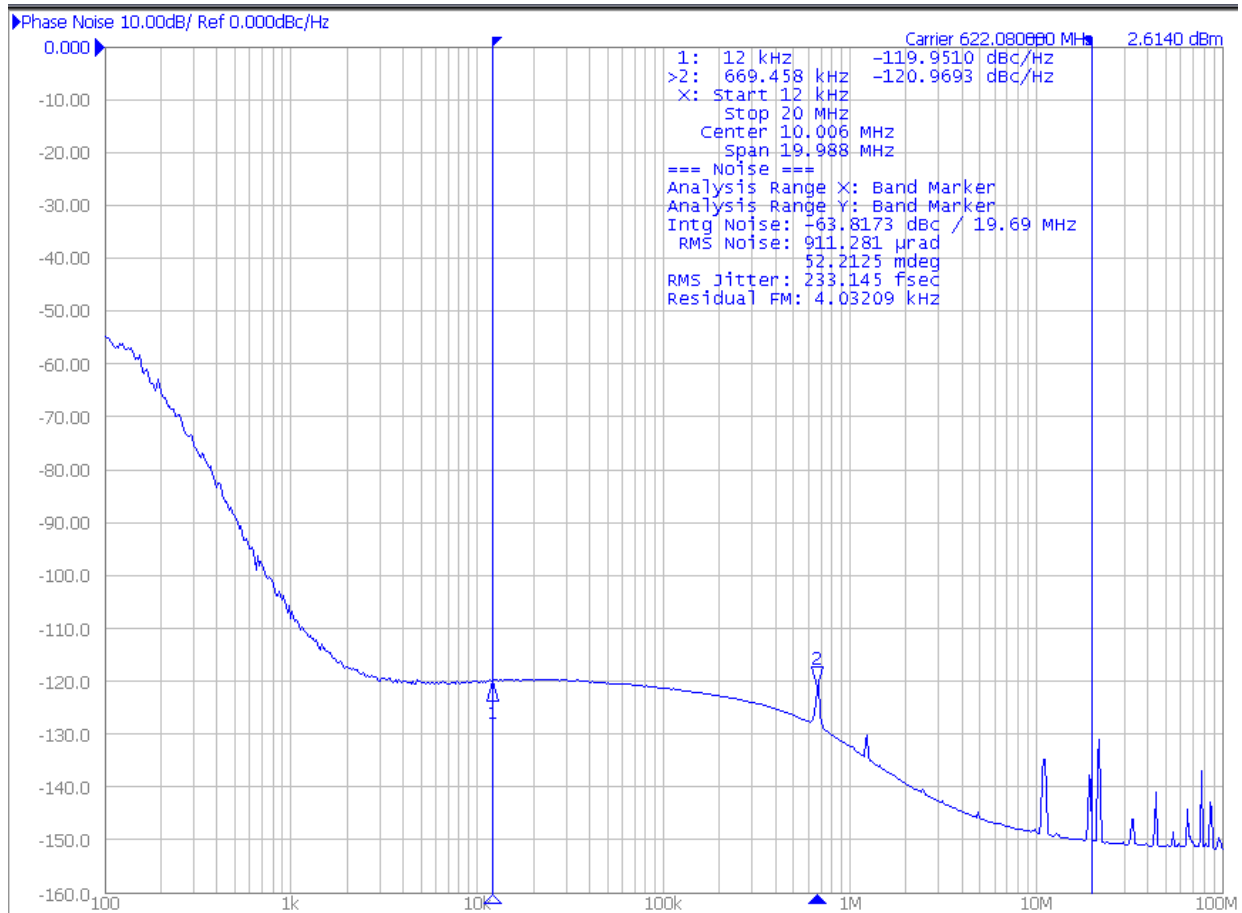
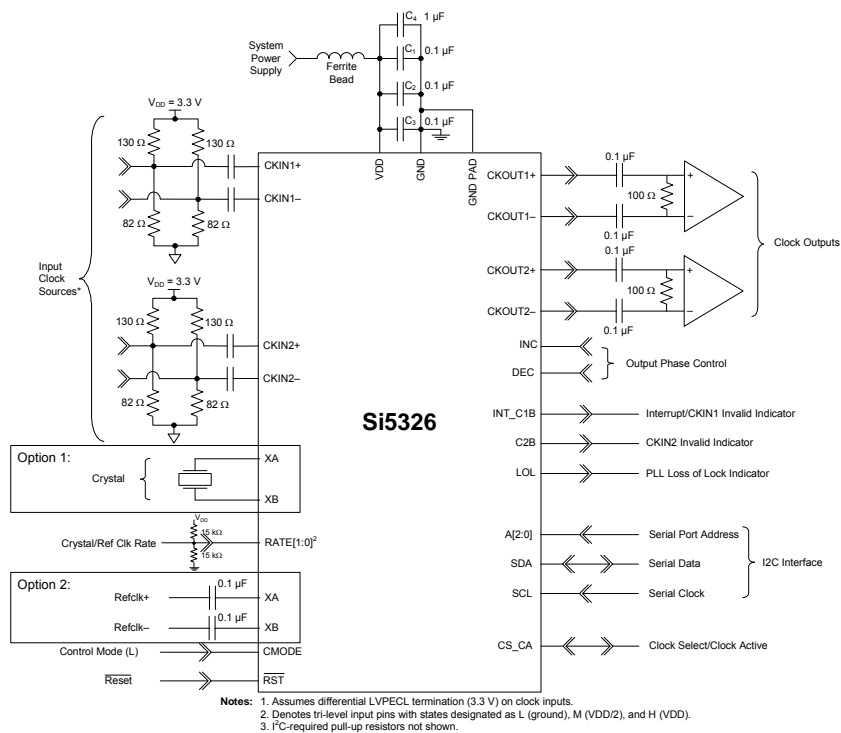

Figure 3. Typical Phase Noise Plot

Jitter Band	Jitter, RMS
SONET_OC48, 12 kHz to 20 MHz	249 fs
SONET_OC192_A, 20 kHz to 80 MHz	274 fs
SONET_OC192_B, 4 MHz to 80 MHz	166 fs
SONET_OC192_C, 50 kHz to 80 MHz	267 fs
Brick Wall_800 Hz to 80 MHz	274 fs
<p><b>*Note:</b> Jitter integration bands include low-pass (-20 dB/Dec) and hi-pass (-60 dB/Dec) roll-offs per Telecordia GR-253-CORE.</p>	

### 3. Typical Application Circuit



**Figure 4. Si5326 Typical Application Circuit (I<sup>2</sup>C Control Mode)**

**Note:** For an example schematic and layout, refer to the Si5325/26-EVB User's Guide.

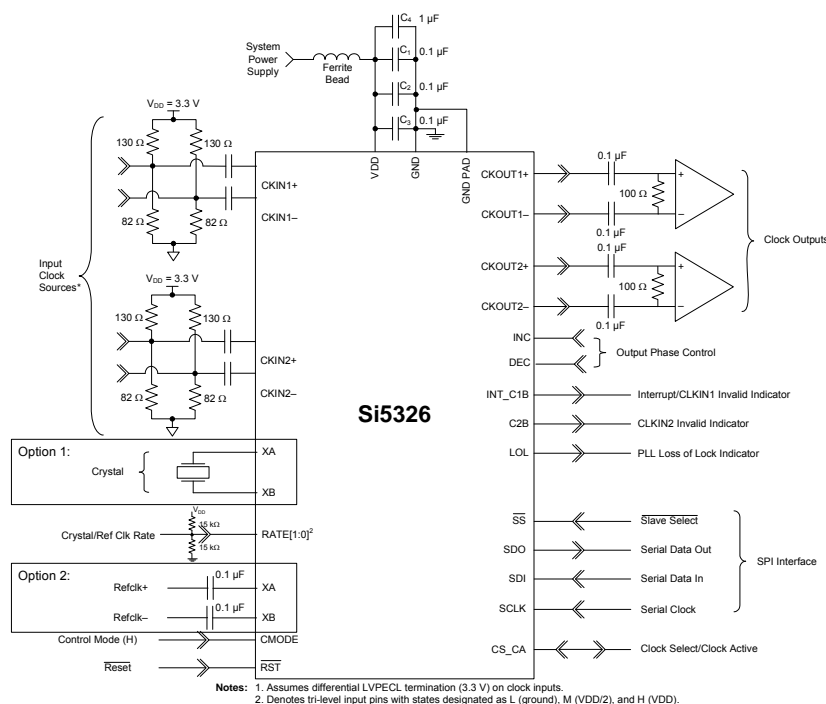

**Figure 5. Si5326 Typical Application Circuit (SPI Control Mode)**

**Note:** For an example schematic and layout, refer to the Si5325/26-EVB User's Guide.

## 4. Functional Description

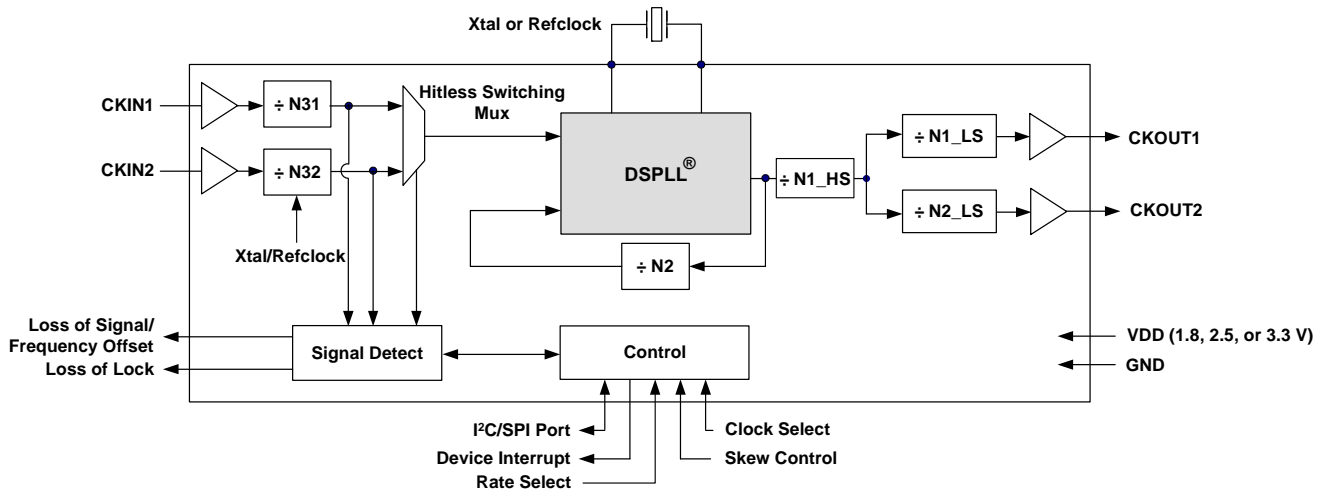

Figure 6. Functional Block Diagram

The Si5326 is a jitter-attenuating precision clock multiplier for applications requiring sub 1 ps jitter performance. The Si5326 accepts two input clocks ranging from 2 kHz to 710 MHz and generates two output clocks ranging from 2 kHz to 945 MHz and select frequencies to 1.4 GHz. The Si5326 can also use its crystal oscillator as a clock source for frequency synthesis. The device provides virtually any frequency translation combination across this operating range. Independent dividers are available for each input clock and output clock, so the Si5326 can accept input clocks at different frequencies and it can generate output clocks at different frequencies. The Si5326 input clock frequency and clock multiplication ratio are programmable through an I<sup>2</sup>C or SPI interface. Silicon Laboratories offers a PC-based software utility, *DSPLLsim*, that can be used to determine the optimum PLL divider settings for a given input frequency/clock multiplication ratio combination that minimizes phase noise and power consumption. This utility can be downloaded from <http://www.silabs.com/timing>.

The Si5326 is based on Silicon Laboratories' 3rd-generation DSPLL<sup>®</sup> technology, which provides any frequency synthesis and jitter attenuation in a highly integrated PLL solution that eliminates the need for external VCXO and loop filter components. The Si5326 PLL loop bandwidth is digitally programmable and supports a range from 60 Hz to 8.4 kHz. The *DSPLLsim* software utility can be used to calculate valid loop bandwidth settings for a given input clock frequency/clock multiplication ratio.

The Si5326 supports hitless switching between the two synchronous input clocks in compliance with GR-253-CORE that greatly minimizes the propagation of phase transients to the clock outputs during an input clock transition (maximum 200 ps phase change). Manual and automatic revertive and non-revertive input clock switching options are available. The Si5326 monitors both input clocks for loss-of-signal (LOS) and provides a LOS alarm (INT\_C1B and C2B) when it detects missing pulses on either input clock. The device monitors the lock status of the PLL. The lock detect algorithm works by continuously monitoring the phase of the input clock in relation to the phase of the feedback clock. The Si5326 also monitors frequency offset alarms (FOS), which indicate if an input clock is within a specified frequency band relative to the frequency of a reference clock. Both Stratum 3/3E and SONET Minimum Clock (SMC) FOS thresholds are supported. The Si5326 provides a digital hold capability that allows the device to continue generation of a stable output clock when the selected input reference is lost. During digital hold, the DSPLL generates an output frequency based on a historical average frequency that existed for a fixed amount of time before the error event occurred, eliminating the effects of phase and frequency transients that may occur immediately preceding digital hold.

The Si5326 has two differential clock outputs. The electrical format of each clock output is independently programmable to support LVPECL, LVDS, CML, or CMOS loads. If not required, the second clock output can be powered down to minimize power consumption. The phase difference between the selected input clock and the output clocks is adjustable in 200 ps increments for system skew control using the *CLAT*[7:0] register. Fine phase adjustment is available and is set using the *FLAT* register bits. The nominal range and resolution of the *FLAT*[14:0] skew adjustment word are:  $\pm 110$  ps and 3 ps, respectively. In addition, the phase of one output clock may be adjusted in relation to the phase of the other output clock. The resolution varies from 800 ps to 2.2 ns depending on the PLL divider settings. See Table 8 for instructions on ensuring output-to-output alignment. The input to output skew is not specified. The *DSPLLsim* software utility determines the phase offset resolution for a given input clock/clock multiplication ratio combination. For system-level debugging, a bypass mode is available which drives the output clock directly from the input clock, bypassing the internal DSPLL. The device is powered by a single 1.8, 2.5, or 3.3 V supply.

#### 4.1. External Reference

An external, high quality clock or a low-cost 114.285 MHz 3rd overtone crystal is used as part of a fixed-frequency oscillator within the DSPLL. This external reference is required for the device to perform jitter attenuation. Silicon Laboratories recommends using a high quality crystal. Specific recommendations may be found in the Family Reference Manual.

In digital hold, the DSPLL remains locked and tracks the external reference. Note that crystals can have temperature sensitivities.

#### 4.2. Further Documentation

Consult the Silicon Laboratories Si53xx Any Frequency Precision Clock Family Reference Manual (FRM) for detailed information about the Si5326 functions. Additional design support is available from Silicon Laboratories through your distributor.

Silicon Laboratories has developed a PC-based software utility called *DSPLLsim* to simplify device configuration, including frequency planning and loop bandwidth selection. The FRM and this utility can be downloaded from <http://www.silabs.com/timing>.

**Table 8. CKOUT\_ALWAYS\_ON and SQ\_ICAL Truth Table**

CKOUT_ALWAYS_ON	SQ_ICAL	Results
0	0	CKOUT OFF until after the first ICAL
0	1	CKOUT OFF until after the first successful ICAL (i.e., when LOL is low)
1	0	CKOUT always ON, including during an ICAL
1	1	CKOUT always ON, including during an ICAL. Use these settings to preserve output-to-output skew

## 5. Register Map

All register bits that are not defined in this map should always be written with the specified Reset Values. The writing to these bits of values other than the specified Reset Values may result in undefined device behavior. Registers not listed, such as Register 64, should never be written to.

Register	D7	D6	D5	D4	D3	D2	D1	D0
0		FREE_RUN	CKOUT_ALWAYS_ON				BYPASS_REG	
1					CK_PRIOR2[1:0]		CK_PRIOR[1:0]	
2	BWSEL_REG[3:0]							
3	CKSEL_REG[1:0]		DHOLD	SQ_ICAL				
4	AUTOSEL_REG[1:0]		HST_DEL[4:0]					
5	ICMOS[1:0]							
6		SLEEP	SFOUT2_REG[2:0]			SFOUT1_REG[2:0]		
7						FOSREFSEL[2:0]		
8	HLOG_2[1:0]		HLOG_1[1:0]					
9	HIST_AVG[4:0]							
10					DSBL2_REG	DSBL1_REG		
11							PD_CK2	PD_CK1
16	CLAT[7:0]							
17	FLAT_VALID	FLAT[14:8]						
18	FLAT[7:0]							
19	FOS_EN	FOS_THR[1:0]		VALTIME[1:0]		LOCK[T2:0]		
20					CK2_BAD_PIN	CK1_BAD_PIN	LOL_PIN	INT_PIN
21	INCDEC_PIN						CK1_ACTV_PIN	CKSEL_PIN
22					CK_ACTV_POL	CK_BAD_POL	LOL_POL	INT_POL
23						LOS2_MSK	LOS1_MSK	LOSX_MSK
24						FOS2_MSK	FOS1_MSK	LOL_MSK
25	N1_HS[2:0]							
31					NC1_LS[19:16]			
32	NC1_LS[15:8]							

Register	D7	D6	D5	D4	D3	D2	D1	D0
33	NC1_LS[7:0]							
34	NC2_LS[19:16]							
35	NC2_LS[15:8]							
36	NC2_LS[7:0]							
40	N2_HS[2:0]					N2_LS[19:16]		
41	N2_LS[15:8]							
42	N2_LS[7:0]							
43	N31[18:16]							
44	N31[15:8]							
45	N31[7:0]							
46	N32[18:16]							
47	N32[15:8]							
48	N32[7:0]							
55	CLKIN2RATE[2:0]				CLKIN1RATE[2:0]			
128	CK2_ACTV_REG CK1_ACTV_REG							
129	LOS2_INT LOS1_INT LOSX_INT							
130	CLAT- PROGRESS	DIGHOLD- VALID			FOS2_INT FOS1_INT		LOL_INT	
131	LOS2_FLG LOS1_FLG LOSX_FLG							
132	FOS2_FLG FOS1_FLG LOL_FLG							
134	PARTNUM_RO[11:4]							
135	PARTNUM_RO[3:0]				REVID_RO[3:0]			
136	RST_REG	ICAL			GRADE_RO[1:0]			
138	LOS2_EN [1:1] LOS1_EN [1:1]							
139	LOS2_EN [0:0] LOS1_EN [0:0] FOS2_EN FOS1_EN							
142	INDEPENDENTSKEW1[7:0]							
143	INDEPENDENTSKEW2[7:0]							

## 6. Register Descriptions

### Register 0.

Bit	D7	D6	D5	D4	D3	D2	D1	D0
<b>Name</b>		FREE_ RUN	CKOUT_ ALWAYS_ ON				BYPASS_ REG	
<b>Type</b>	R	R/W	R/W	R	R	R	R/W	R

Reset value = 0001 0100

Bit	Name	Function
7	Reserved	<b>Reserved.</b>
6	FREE_RUN	<b>Free Run.</b> Internal to the device, route XA/XB to CKIN2. This allows the device to lock to its XA-XB reference. 0: Disable 1: Enable
5	CKOUT_ ALWAYS_ON	<b>CKOUT Always On.</b> This will bypass the SQ_ICAL function. Output will be available even if SQ_ICAL is on and ICAL is not complete or successful. See Table 8 on page 19. 0: Squelch output until part is calibrated (ICAL). 1: Provide an output. Note: The frequency may be significantly off and variable until the part is calibrated.
4:2	Reserved	<b>Reserved.</b>
1	BYPASS_ REG	<b>Bypass Register.</b> This bit enables or disables the PLL bypass mode. Use only when the device is in digital hold or before the first ICAL. 0: Normal operation 1: Bypass mode. Selected input clock is connected to CKOUT buffers, bypassing the PLL. Bypass mode does not support CMOS clock outputs.
0	Reserved	<b>Reserved.</b>

**Register 1.**

Bit	D7	D6	D5	D4	D3	D2	D1	D0
<b>Name</b>	Reserved				CK_PRIOR2 [1:0]		CK_PRIOR1 [1:0]	
<b>Type</b>	R				R/W		R/W	

Reset value = 1110 0100

Bit	Name	Function
7:4	Reserved	<b>Reserved.</b>
3:2	CK_PRIOR2 [1:0]	<b>CK_PRIOR 2.</b> Selects which of the input clocks will be 2nd priority in the autoselection state machine. 00: CKIN1 is 2nd priority. 01: CKIN2 is 2nd priority. 10: Reserved 11: Reserved
1:0	CK_PRIOR1 [1:0]	<b>CK_PRIOR 1.</b> Selects which of the input clocks will be 1st priority in the autoselection state machine. 00: CKIN1 is 1st priority. 01: CKIN2 is 1st priority. 10: Reserved 11: Reserved

**Register 2.**

Bit	D7	D6	D5	D4	D3	D2	D1	D0
<b>Name</b>	BWSEL_REG [3:0]				Reserved			
<b>Type</b>	R/W				R			

Reset value = 0100 0010

Bit	Name	Function
7:4	BWSEL_REG [3:0]	<b>BWSEL_REG.</b> Selects nominal f3dB bandwidth for PLL. See DSPLL <i>sim</i> for settings. After BWSEL_REG is written with a new value, an ICAL is required for the change to take effect.
3:0	Reserved	<b>Reserved.</b>

## Register 3.

Bit	D7	D6	D5	D4	D3	D2	D1	D0
<b>Name</b>	CKSEL_REG [1:0]		DHOLD	SQ_ICAL	Reserved			
<b>Type</b>	R/W		R/W	R/W	R			

Reset value = 0000 0101

Bit	Name	Function
7:6	CKSEL_REG [1:0]	<p><b>CKSEL_REG.</b></p> <p>If the device is operating in register-based manual clock selection mode (AUTOSEL_REG = 00), and CKSEL_PIN = 0, then these bits select which input clock will be the active input clock. If CKSEL_PIN = 1 and AUTOSEL_REG = 00, the CS_CA input pin continues to control clock selection and CKSEL_REG is of no consequence.</p> <p>00: CKIN_1 selected.            01: CKIN_2 selected.            10: Reserved            11: Reserved</p>
5	DHOLD	<p><b>DHOLD.</b></p> <p>Forces the part into digital hold. This bit overrides all other manual and automatic clock selection controls.</p> <p>0: Normal operation.            1: Force digital hold mode. Overrides all other settings and ignores the quality of all of the input clocks.</p>
4	SQ_ICAL	<p><b>SQ_ICAL.</b></p> <p>This bit determines if the output clocks will remain enabled or be squelched (disabled) during an internal calibration. See Table 8 on page 19.</p> <p>0: Output clocks enabled during ICAL.            1: Output clocks disabled during ICAL.</p>
3:0	Reserved	<b>Reserved.</b>

**Register 4.**

Bit	D7	D6	D5	D4	D3	D2	D1	D0
<b>Name</b>	AUTOSEL_REG [1:0]		Reserved	HIST_DEL [4:0]				
<b>Type</b>	R/W		R	R/W				

Reset value = 0001 0010

Bit	Name	Function
7:6	AUTOSEL_REG [1:0]	<b>AUTOSEL_REG [1:0].</b> Selects method of input clock selection to be used. 00: Manual (either register or pin controlled, see CKSEL_PIN) 01: Automatic Non-Revertive 10: Automatic Revertive 11: Reserved See the Si53xx Family Reference Manual for a detailed description.
5	Reserved	<b>Reserved.</b>
4:0	HIST_DEL [4:0]	<b>HIST_DEL [4:0].</b> Selects amount of delay to be used in generating the history information used for Digital Hold. See the Si53xx Family Reference Manual for a detailed description.

**Register 5.**

Bit	D7	D6	D5	D4	D3	D2	D1	D0
<b>Name</b>	ICMOS [1:0]		Reserved					
<b>Type</b>	R/W		R					

Reset value = 1110 1101

Bit	Name	Function
7:6	ICMOS [1:0]	<b>ICMOS [1:0].</b> When the output buffer is set to CMOS mode, these bits determine the output buffer drive strength. The first number below refers to 3.3 V operation; the second to 1.8 V operation. These values assume CKOUT+ is tied to CKOUT-. 00: 8mA/2mA 01: 16mA/4mA 10: 24mA/6mA 11: 32mA/8mA
5:0	Reserved	<b>Reserved.</b>

## Register 6.

Bit	D7	D6	D5	D4	D3	D2	D1	D0
<b>Name</b>	Reserved	SLEEP	SFOUT2_REG [2:0]			SFOUT1_REG [2:0]		
<b>Type</b>	R	R/W	R/W			R/W		

Reset value = 0010 1101

Bit	Name	Function
7	Reserved	<b>Reserved.</b>
6	SLEEP	<p><b>SLEEP.</b></p> <p>In sleep mode, all clock outputs are disabled and the maximum amount of internal circuitry is powered down to reduce power dissipation and noise generation. This bit overrides the SFOUT<sub>n</sub>_REG[2:0] output signal format settings.</p> <p>0: Normal operation 1: Sleep mode</p>
5:3	SFOUT2_REG [2:0]	<p><b>SFOUT2_REG [2:0].</b></p> <p>Controls output signal format and disable for CKOUT2 output buffer.</p> <p>000: Reserved 001: Disable 010: CMOS (Bypass mode not supported) 011: Low swing LVDS 100: Reserved 101: LVPECL 110: CML 111: LVDS</p> <p><b>Note:</b> LVPECL requires a nominal <math>V_{DD} \geq 2.5</math> V.</p>
2:0	SFOUT1_REG [2:0]	<p><b>SFOUT1_REG [2:0].</b></p> <p>Controls output signal format and disable for CKOUT1 output buffer.</p> <p>000: Reserved 001: Disable 010: CMOS (Bypass mode not supported) 011: Low swing LVDS 100: Reserved 101: LVPECL 110: CML 111: LVDS</p> <p><b>Note:</b> LVPECL requires a nominal <math>V_{DD} \geq 2.5</math> V.</p>

**Register 7.**

Bit	D7	D6	D5	D4	D3	D2	D1	D0
<b>Name</b>	Reserved					FOSREFSEL [2:0]		
<b>Type</b>	R					R/W		

Reset value = 0010 1010

Bit	Name	Function
7:3	Reserved.	<b>Reserved.</b>
2:0	FOSREFSEL [2:0]	<b>FOSREFSEL [2:0].</b> Selects which input clock is used as the reference frequency for frequency offset (FOS) alarms. 000: XA/XB (External reference) 001: CKIN1 010: CKIN2 011: Reserved 100: Reserved 101: Reserved 110: Reserved 111: Reserved

## Register 8.

Bit	D7	D6	D5	D4	D3	D2	D1	D0
<b>Name</b>	HLOG_2[1:0]		HLOG_1[1:0]		Reserved			
<b>Type</b>	R/W		R/W		R			

Reset value = 0000 0000

Bit	Name	Function
7:6	HLOG_2 [1:0]	<b>HLOG_2 [1:0].</b> 00: Normal operation 01: Holds CKOUT2 output at static logic 0. Entrance and exit from this state will occur without glitches or runt pulses. 10: Holds CKOUT2 output at static logic 1. Entrance and exit from this state will occur without glitches or runt pulses. 11: Reserved
5:4		<b>HLOG_1 [1:0].</b> 00: Normal operation 01: Holds CKOUT1 output at static logic 0. Entrance and exit from this state will occur without glitches or runt pulses. 10: Holds CKOUT1 output at static logic 1. Entrance and exit from this state will occur without glitches or runt pulses. 11: Reserved
3:0	Reserved	<b>Reserved.</b>

## Register 9.

Bit	D7	D6	D5	D4	D3	D2	D1	D0
<b>Name</b>	HIST_AVG [4:0]					Reserved		
<b>Type</b>	R/W					R	R	R

Reset value = 1100 0000

Bit	Name	Function
7:3	HIST_AVG [4:0]	<b>HIST_AVG [4:0].</b> Selects amount of averaging time to be used in generating the history information for Digital Hold. See the Si53xx Family Reference Manual for a detailed description
2:0	Reserved	<b>Reserved.</b>

**Register 10.**

Bit	D7	D6	D5	D4	D3	D2	D1	D0
<b>Name</b>	Reserved				DSBL2_REG	DSBL1_REG	Reserved	Reserved
<b>Type</b>	R				R/W	R/W	R	R

Reset value = 0000 0000

Bit	Name	Function
7:4	Reserved	<b>Reserved.</b>
3	DSBL2_REG	<b>DSBL2_REG.</b> This bit controls the powerdown of the CKOUT2 output buffer. If disable mode is selected, the N2_LS output divider is also powered down. 0: CKOUT2 enabled 1: CKOUT2 disabled
2	DSBL1_REG	<b>DSBL1_REG.</b> This bit controls the powerdown of the CKOUT1 output buffer. If disable mode is selected, the N1_LS output divider is also powered down. 0: CKOUT1 enabled 1: CKOUT1 disabled
1:0	Reserved	<b>Reserved.</b>

## Register 11.

Bit	D7	D6	D5	D4	D3	D2	D1	D0
Name	Reserved						PD_CK2	PD_CK1
Type	R						R/W	R/W

Reset value = 0100 0000

Bit	Name	Function
7:2	Reserved	<b>Reserved.</b>
1	PD_CK2	<b>PD_CK2.</b> This bit controls the powerdown of the CKIN2 input buffer. 0: CKIN2 enabled 1: CKIN2 disabled
0	PD_CK1	<b>PD_CK1.</b> This bit controls the powerdown of the CKIN1 input buffer. 0: CKIN1 enabled 1: CKIN1 disabled

## Register 16.

Bit	D7	D6	D5	D4	D3	D2	D1	D0
Name	CLAT [7:0]							
Type	R/W							

Reset value = 0000 0000

Bit	Name	Function
7:0	CLAT [7:0]	<b>CLAT [7:0].</b> With INCDEC_PIN = 0, this register sets the phase delay for CKOUTn in units of 1/Fosc. This can take as long as 20 seconds. 01111111 = 127/Fosc (2s compliment) 00000000 = 0 10000000 = -128/Fosc (2s compliment) If NI_HS[2:0] = 000, increasing CLAT does not work.

**Register 17.**

Bit	D7	D6	D5	D4	D3	D2	D1	D0
<b>Name</b>	FLAT_VALID	FLAT [14:8]						
<b>Type</b>	R/W	R/W						

Reset value = 1000 0000

Bit	Name	Function
7	FLAT_VALID	<p><b>FLAT_VALID.</b></p> <p>Before writing a new FLAT[14:0] value, this bit must be set to zero, which causes the existing FLAT[14:0] value to be held internally for use while the new value is being written. Once the new FLAT[14:0] value is completely written, set FLAT_VALID = 1 to enable its use.</p> <p>0: Memorize existing FLAT[14:0] value and ignore intermediate register values during write of new FLAT[14:0] value.</p> <p>1: Use FLAT[14:0] value directly from registers.</p>
6:0	FLAT [14:8]	<p><b>FLAT [14:8].</b></p> <p>Fine resolution control for overall device skew from input clocks to output clocks. Positive values increase the skew. See <i>DSPLLsim</i> for details.</p> <p>FLAT [14:0] is a 2's complement number.</p>

**Register 18.**

Bit	D7	D6	D5	D4	D3	D2	D1	D0
<b>Name</b>	FLAT [7:0]							
<b>Type</b>	R/W							

Reset value = 0000 0000

Bit	Name	Function
7:0	FLAT [7:0]	<p><b>FLAT [7:0].</b></p> <p>Fine resolution control for overall device skew from input clocks to output clocks. Positive values increase the skew. See <i>DSPLLsim</i> for details.</p> <p>FLAT [14:0] is a 2's complement number.</p>

## Register 19.

Bit	D7	D6	D5	D4	D3	D2	D1	D0
<b>Name</b>	FOS_EN	FOS_THR [1:0]		VALTIME [1:0]		LOCKT [2:0]		
<b>Type</b>	R/W	R/W		R/W		R/W		

Reset value = 0010 1100

Bit	Name	Function
7	FOS_EN	<p><b>FOS_EN.</b></p> <p>Frequency Offset Enable globally disables FOS. See the individual FOS enables (FOSX_EN, register 139).</p> <p>0: FOS disable</p> <p>1: FOS enabled by FOSx_EN</p>
6:5	FOS_THR [1:0]	<p><b>FOS_THR [1:0].</b></p> <p>Frequency Offset at which FOS is declared (relative to the selected FOS reference):</p> <p>00: ± 11 to 12 ppm (Stratum 3/3E compliant, with a Stratum 3/3E used for REFCLK)</p> <p>01: ± 48 to 49 ppm (SMC)</p> <p>10: ± 30 ppm (SONET Minimum Clock (SMC), with a Stratum 3/3E used for REFCLK.)</p> <p>11: ± 200 ppm</p>
4:3	VALTIME [1:0]	<p><b>VALTIME [1:0].</b></p> <p>Sets amount of time for input clock to be valid before the associated alarm is removed.</p> <p>00: 2 ms</p> <p>01: 100 ms</p> <p>10: 200 ms</p> <p>11: 13 seconds</p>
2:0	LOCKT [2:0]	<p><b>LOCKT [2:0].</b></p> <p>Sets retrigger interval for one shot monitoring phase detector output. One shot is triggered by phase slip in DSPLL. Refer to the Si53xx Family Reference Manual for more details.</p> <p>000: 106 ms</p> <p>001: 53 ms</p> <p>010: 26.5 ms</p> <p>011: 13.3 ms</p> <p>100: 6.6 ms</p> <p>101: 3.3 ms</p> <p>110: 1.66 ms</p> <p>111: .833 ms</p>

**Register 20.**

Bit	D7	D6	D5	D4	D3	D2	D1	D0
<b>Name</b>	Reserved				CK2_BAD_PIN	CK1_BAD_PIN	LOL_PIN	INT_PIN
<b>Type</b>	R				R/W	R/W	R/W	R/W

Reset value = 0011 1110

Bit	Name	Function
7:4	Reserved	<b>Reserved.</b>
3	CK2_BAD_PIN	<b>CK2_BAD_PIN.</b> The CK2_BAD status can be reflected on the C2B output pin. 0: C2B output pin tristated 1: C2B status reflected to output pin
2	CK1_BAD_PIN	<b>CK1_BAD_PIN.</b> Either LOS1 or INT (see INT_PIN) status can be reflected on the INT_C1B output pin. 0: INT_C1B output pin tristated 1: LOS1 or INT (see INT_PIN) status reflected to output pin
1	LOL_PIN	<b>LOL_PIN.</b> The LOL_INT status bit can be reflected on the LOL output pin. 0: LOL output pin tristated 1: LOL_INT status reflected to output pin
0	INT_PIN	<b>INT_PIN.</b> Reflects the interrupt status on the INT_C1B output pin. 0: Interrupt status not displayed on INT_C1B output pin. Instead, the INT_C1B pin indicates when CKIN1 is bad. If CK1_BAD_PIN = 0, INT_C1B output pin is tristated. 1: Interrupt status reflected to output pin.

## Register 21.

Bit	D7	D6	D5	D4	D3	D2	D1	D0
<b>Name</b>	INCDEC_PIN	Reserved					CK1_ACTV_PIN	CKSEL_PIN
<b>Type</b>	R/W	Force 1	R	R	R	R	R/W	R/W

Reset value = 1111 1111

Bit	Name	Function
7	INCDEC_PIN	<p><b>INCDEC_PIN.</b></p> <p>Determines how coarse skew adjustments can be made. The adjustments can be made via hardware using the INC/DEC pins or via software using the CLAT register.</p> <p>0: INC and DEC inputs ignored; use CLAT register to adjust skew.</p> <p>1: INC and DEC inputs control output phase increment/decrement.</p>
6:2	Reserved	<b>Reserved.</b>
1	CK1_ACTV_PIN	<p><b>CK1_ACTV_PIN.</b></p> <p>The CK1_ACTV_REG status bit can be reflected to the CS_CA output pin using the CK1_ACTV_PIN enable function. CK1_ACTV_PIN is of consequence only when pin controlled clock selection is being used. (See CKSEL_PIN)</p> <p>0: CS_CA output pin tristated.</p> <p>1: Clock Active status reflected to output pin.</p>
0	CKSEL_PIN	<p><b>CKSEL_PIN.</b></p> <p>If manual clock selection is being used, clock selection can be controlled via the CKSEL_REG[1:0] register bits or the CS_CA input pin. This bit is only active when AUTOSEL_REG = Manual.</p> <p>0: CS_CA pin is ignored. CKSEL_REG[1:0] register bits control clock selection.</p> <p>1: CS_CA input pin controls clock selection.</p>

**Register 22.**

Bit	D7	D6	D5	D4	D3	D2	D1	D0
<b>Name</b>	Reserved				CK_ACTV_POL	CK_BAD_POL	LOL_POL	INT_POL
<b>Type</b>	R				R/W	R/W	R/W	R/W

Reset value = 1101 1111

Bit	Name	Function
7:4	Reserved	<b>Reserved.</b>
3	CK_ACTV_POL	<b>CK_ACTV_POL.</b> Sets the active polarity for the CS_CA signals when reflected on an output pin. 0: Active low 1: Active high
2	CK_BAD_POL	<b>CK_BAD_POL.</b> Sets the active polarity for the INT_C1B and C2B signals when reflected on output pins. 0: Active low 1: Active high
1	LOL_POL	<b>LOL_POL.</b> Sets the active polarity for the LOL status when reflected on an output pin. 0: Active low 1: Active high
0	INT_POL	<b>INT_POL.</b> Sets the active polarity for the interrupt status when reflected on the INT_C1B output pin. 0: Active low 1: Active high

## Register 23.

Bit	D7	D6	D5	D4	D3	D2	D1	D0
Name	Reserved					LOS2_MSK	LOS1_MSK	LOSX_MSK
Type	R					R/W	R/W	R/W

Reset value = 0001 1111

Bit	Name	Function
7:3	Reserved	<b>Reserved.</b>
2	LOS2_MSK	<p><b>LOS2_MSK.</b></p> <p>Determines if a LOS on CKIN2 (LOS2_FLG) is used in the generation of an interrupt. Writes to this register do not change the value held in the LOS2_FLG register.</p> <p>0: LOS2 alarm triggers active interrupt on INT_C1B output (if INT_PIN=1).</p> <p>1: LOS2_FLG ignored in generating interrupt output.</p>
1	LOS1_MSK	<p><b>LOS1_MSK.</b></p> <p>Determines if a LOS on CKIN1 (LOS1_FLG) is used in the generation of an interrupt. Writes to this register do not change the value held in the LOS1_FLG register.</p> <p>0: LOS1 alarm triggers active interrupt on INT_C1B output (if INT_PIN=1).</p> <p>1: LOS1_FLG ignored in generating interrupt output.</p>
0	LOSX_MSK	<p><b>LOSX_MSK.</b></p> <p>Determines if a LOS on XA/XB(LOSX_FLG) is used in the generation of an interrupt. Writes to this register do not change the value held in the LOSX_FLG register.</p> <p>0: LOSX alarm triggers active interrupt on INT_C1B output (if INT_PIN=1).</p> <p>1: LOSX_FLG ignored in generating interrupt output.</p>

**Register 24.**

Bit	D7	D6	D5	D4	D3	D2	D1	D0
<b>Name</b>	Reserved					FOS2_MS MSK	FOS1_MS MSK	LOL_MS MSK
<b>Type</b>	R					R/W	R/W	R/W

Reset value = 0011 1111

Bit	Name	Function
7:3	Reserved	<b>Reserved.</b>
2	FOS2_MS MSK	<b>FOS2_MS MSK.</b> Determines if the FOS2_FLG is used in the generation of an interrupt. Writes to this register do not change the value held in the FOS2_FLG register. 0: FOS2 alarm triggers active interrupt on INT_C1B output (if INT_PIN=1). 1: FOS2_FLG ignored in generating interrupt output.
1	FOS1_MS MSK	<b>FOS1_MS MSK.</b> Determines if the FOS1_FLG is used in the generation of an interrupt. Writes to this register do not change the value held in the FOS1_FLG register. 0: FOS1 alarm triggers active interrupt on INT_C1B output (if INT_PIN=1). 1: FOS1_FLG ignored in generating interrupt output.
0	LOL_MS MSK	<b>LOL_MS MSK.</b> Determines if the LOL_FLG is used in the generation of an interrupt. Writes to this register do not change the value held in the LOL_FLG register. 0: LOL alarm triggers active interrupt on INT_C1B output (if INT_PIN=1). 1: LOL_FLG ignored in generating interrupt output.

# Si5326

## Register 25.

Bit	D7	D6	D5	D4	D3	D2	D1	D0
<b>Name</b>	N1_HS [2:0]				Reserved			
<b>Type</b>	R/W				R			

Reset value = 0010 0000

Bit	Name	Function
7:5	N1_HS [2:0]	<b>N1_HS [2:0].</b> Sets value for N1 high speed divider which drives NCn_LS (n = 1 to 2) low-speed divider. 000: N1= 4 Note: Changing the coarse skew via the INC pin or <u>CLAT</u> register is disabled for this value. 001: N1= 5 010: N1= 6 011: N1= 7 100: N1= 8 101: N1= 9 110: N1= 10 111: N1= 11
4:0	Reserved	<b>Reserved.</b>

## Register 31.

Bit	D7	D6	D5	D4	D3	D2	D1	D0
<b>Name</b>	Reserved				NC1_LS [19:16]			
<b>Type</b>	R				R/W			

Reset value = 0000 0000

Bit	Name	Function
7:4	Reserved	<b>Reserved.</b>
3:0	NC1_LS [19:16]	<b>NC1_LS [19:16].</b> Sets value for NC1 low-speed divider, which drives CKOUT1 output. Must be 0 or odd. 00000000000000000000 = 1 00000000000000000001 = 2 00000000000000000011 = 4 00000000000000000101 = 6 ... 11111111111111111111 = 2 <sup>20</sup> Valid divider values=[1, 2, 4, 6, ..., 2 <sup>20</sup> ]

**Register 32.**

Bit	D7	D6	D5	D4	D3	D2	D1	D0
<b>Name</b>	NC1_LS [15:8]							
<b>Type</b>	R/W							

Reset value = 0000 0000

Bit	Name	Function
7:0	NC1_LS [15:8]	<b>NC1_LS [15:8].</b> Sets value for NC1 low-speed divider, which drives CKOUT1 output. Must be 0 or odd. 00000000000000000000 = 1 00000000000000000001 = 2 00000000000000000011 = 4 00000000000000000101 = 6 ... 11111111111111111111=2^20 Valid divider values=[1, 2, 4, 6, ..., 2^20]

**Register 33.**

Bit	D7	D6	D5	D4	D3	D2	D1	D0
<b>Name</b>	NC1_LS [7:0]							
<b>Type</b>	R/W							

Reset value = 0011 0001

Bit	Name	Function
7:0	NC1_LS [19:0]	<b>NC1_LS [7:0].</b> Sets value for N1 low-speed divider, which drives CKOUT1 output. Must be 0 or odd. 00000000000000000000 = 1 00000000000000000001 = 2 00000000000000000011 = 4 00000000000000000101 = 6 ... 11111111111111111111=2^20 Valid divider values=[1, 2, 4, 6, ..., 2^20]

## Register 34.

Bit	D7	D6	D5	D4	D3	D2	D1	D0
<b>Name</b>	Reserved				NC2_LS [19:16]			
<b>Type</b>	R				R/W			

Reset value = 0000 0000

Bit	Name	Function
7:4	Reserved	<b>Reserved.</b>
3:0	NC2_LS [19:16]	<b>NC2_LS [19:16].</b> Sets value for NC2 low-speed divider, which drives CKOUT2 output. Must be 0 or odd. 00000000000000000000=1 00000000000000000001=2 00000000000000000011=4 00000000000000000101=6 ... 11111111111111111111=2^20 Valid divider values=[1, 2, 4, 6, ..., 2^20]

## Register 35.

Bit	D7	D6	D5	D4	D3	D2	D1	D0
<b>Name</b>	NC2_LS [15:8]							
<b>Type</b>	R/W							

Reset value = 0000 0000

Bit	Name	Function
7:0	NC2_LS [15:8]	<b>NC2_LS [15:8].</b> Sets value for NC2 low-speed divider, which drives CKOUT2 output. Must be 0 or odd. 00000000000000000000 = 1 00000000000000000001 = 2 00000000000000000011 = 4 00000000000000000101 = 6 ... 11111111111111111111=2^20 Valid divider values=[1, 2, 4, 6, ..., 2^20]

**Register 36.**

Bit	D7	D6	D5	D4	D3	D2	D1	D0
<b>Name</b>	NC2_LS [7:0]							
<b>Type</b>	R/W							

Reset value = 0011 0001

Bit	Name	Function
7:0	NC2_LS [7:0]	<p><b>NC2_LS [7:0].</b></p> <p>Sets value for NC2 low-speed divider, which drives CKOUT2 output. Must be 0 or odd.</p> <p>00000000000000000000 = 1</p> <p>00000000000000000001 = 2</p> <p>00000000000000000011 = 4</p> <p>00000000000000000101 = 6</p> <p>...</p> <p>11111111111111111111=2^20</p> <p>Valid divider values=[1, 2, 4, 6, ..., 2^20]</p>

## Register 40.

Bit	D7	D6	D5	D4	D3	D2	D1	D0
<b>Name</b>	N2_HS [2:0]			Reserved	N2_LS [19:16]			
<b>Type</b>	R/W			R	R/W			

Reset value = 1100 0000

Bit	Name	Function
7:5	N2_HS [2:0]	<b>N2_HS [2:0].</b> Sets value for N2 high speed divider, which drives N2LS low-speed divider. 000: 4 001: 5 010: 6 011: 7 100: 8 101: 9 110: 10 111: 11
4	Reserved	<b>Reserved.</b>
3:0	N2_LS [19:16]	<b>N2_LS [19:16].</b> Sets value for N2 low-speed divider, which drives phase detector. 00000000000000000001 = 2 00000000000000000011 = 4 00000000000000000101 = 6 ... 11111111111111111111 = 2 <sup>20</sup> Valid divider values = [2, 4, 6, ..., 2 <sup>20</sup> ]

**Register 41.**

Bit	D7	D6	D5	D4	D3	D2	D1	D0
<b>Name</b>	N2_LS [15:8]							
<b>Type</b>	R/W							

Reset value = 0000 0000

Bit	Name	Function
7:0	N2_LS [15:8]	<p><b>N2_LS [15:8].</b>  Sets value for N2 low-speed divider, which drives phase detector.  00000000000000000001 = 2  00000000000000000011 = 4  00000000000000000101 = 6  ...  11111111111111111111 = 2<sup>20</sup>  Valid divider values = [2, 4, 6, ..., 2<sup>20</sup>]</p>

**Register 42.**

Bit	D7	D6	D5	D4	D3	D2	D1	D0
<b>Name</b>	N2_LS [7:0]							
<b>Type</b>	R/W							

Reset value = 1111 1001

Bit	Name	Function
7:0	N2_LS [7:0]	<p><b>N2_LS [7:0].</b>  Sets value for N2 low-speed divider, which drives phase detector.  00000000000000000001 = 2  00000000000000000011 = 4  00000000000000000101 = 6  ...  11111111111111111111 = 2<sup>20</sup>  Valid divider values = [2, 4, 6, ..., 2<sup>20</sup>]</p>

# Si5326

## Register 43.

Bit	D7	D6	D5	D4	D3	D2	D1	D0
<b>Name</b>	Reserved					N31 [18:16]		
<b>Type</b>	R					R/W		

Reset value = 0000 0000

Bit	Name	Function
7:3	Reserved	<b>Reserved.</b>
2:0	N31 [18:16]	<b>N31 [18:16].</b> Sets value for input divider for CKIN1. 00000000000000000000 = 1 00000000000000000001 = 2 00000000000000000010 = 3 ... 11111111111111111111 = 2 <sup>19</sup> Valid divider values=[1, 2, 3, ..., 2 <sup>19</sup> ]

## Register 44.

Bit	D7	D6	D5	D4	D3	D2	D1	D0
<b>Name</b>	N31_[15:8]							
<b>Type</b>	R/W							

Reset value = 0000 0000

Bit	Name	Function
7:0	N31_[15:8]	<b>N31_[15:8].</b> Sets value for input divider for CKIN1. 00000000000000000000 = 1 00000000000000000001 = 2 00000000000000000010 = 3 ... 11111111111111111111 = 2 <sup>19</sup> Valid divider values=[1, 2, 3, ..., 2 <sup>19</sup> ]

**Register 45.**

Bit	D7	D6	D5	D4	D3	D2	D1	D0
<b>Name</b>	N31_[7:0]							
<b>Type</b>	R/W							

Reset value = 0000 1001

Bit	Name	Function
7:0	N31_[7:0]	<b>N31_[7:0].</b> Sets value for input divider for CKIN1. 00000000000000000000 = 1 00000000000000000001 = 2 00000000000000000010 = 3 ... 11111111111111111111 = 2 <sup>19</sup> Valid divider values=[1, 2, 3, ..., 2 <sup>19</sup> ]

**Register 46.**

Bit	D7	D6	D5	D4	D3	D2	D1	D0
<b>Name</b>	Reserved					N32_[18:16]		
<b>Type</b>	R					R/W		

Reset value = 0000 0000

Bit	Name	Function
7:3	Reserved	<b>Reserved.</b>
2:0	N32_[18:16]	<b>N32_[18:16].</b> Sets value for input divider for CKIN2. 00000000000000000000 = 1 00000000000000000001 = 2 00000000000000000010 = 3 ... 11111111111111111111 = 2 <sup>19</sup> Valid divider values=[1, 2, 3, ..., 2 <sup>19</sup> ]

# Si5326

## Register 47.

Bit	D7	D6	D5	D4	D3	D2	D1	D0
Name	N32_[15:8]							
Type	R/W							

Reset value = 0000 0000

Bit	Name	Function
7:0	N32_[15:8]	<b>N32_[15:8].</b> Sets value for input divider for CKIN2. 00000000000000000000 = 1 00000000000000000001 = 2 00000000000000000010 = 3 ... 11111111111111111111 = 2 <sup>19</sup> Valid divider values=[1, 2, 3, ..., 2 <sup>19</sup> ]

## Register 48.

Bit	D7	D6	D5	D4	D3	D2	D1	D0
Name	N32_[7:0]							
Type	R/W							

Reset value = 0000 1001

Bit	Name	Function
7:0	N32_[7:0]	<b>N32_[7:0].</b> Sets value for input divider for CKIN1. 00000000000000000000 = 1 00000000000000000001 = 2 00000000000000000010 = 3 ... 11111111111111111111 = 2 <sup>19</sup> Valid divider values=[1, 2, 3, ..., 2 <sup>19</sup> ]

**Register 55.**

Bit	D7	D6	D5	D4	D3	D2	D1	D0
<b>Name</b>	Reserved		CLKIN2RATE_[2:0]			CLKIN1RATE[2:0]		
<b>Type</b>	R		R/W			R/W		

Reset value = 0000 0000

Bit	Name	Function
7:6	Reserved	<b>Reserved.</b>
5:3	CLKIN2RATE [2:0]	<b>CLKIN2RATE[2:0].</b> CKINn frequency selection for FOS alarm monitoring. 000: 10 - 27 MHz 001: 25 - 54 MHz 010: 50 - 105 MHz 011: 95 - 215 MHz 100: 190 - 435 MHz 101: 375 - 710 MHz 110: Reserved 111: Reserved
2:0	CLKIN1RATE [2:0]	<b>CLKIN1RATE[2:0].</b> CKINn frequency selection for FOS alarm monitoring. 000: 10 - 27 MHz 001: 25 - 54 MHz 010: 50 - 105 MHz 011: 95 - 215 MHz 100: 190 - 435 MHz 101: 375 - 710 MHz 110: Reserved 111: Reserved

## Register 128.

Bit	D7	D6	D5	D4	D3	D2	D1	D0
Name	Reserved						CK2_ACTV_REG	CK1_ACTV_REG
Type	R						R	R

Reset value = 0010 0000

Bit	Name	Function
7:2	Reserved	<b>Reserved.</b>
1	CK2_ACTV_REG	<b>CK2_ACTV_REG.</b> Indicates if CKIN2 is currently the active clock for the PLL input. 0: CKIN2 is not the active input clock. Either it is not selected or LOS2_INT is 1. 1: CKIN2 is the active input clock.
0	CK1_ACTV_REG	<b>CK1_ACTV_REG.</b> Indicates if CKIN1 is currently the active clock for the PLL input. 0: CKIN1 is not the active input clock. Either it is not selected or LOS1_INT is 1. 1: CKIN1 is the active input clock.

**Register 129.**

Bit	D7	D6	D5	D4	D3	D2	D1	D0
<b>Name</b>	Reserved					LOS2_INT	LOS1_INT	LOSX_INT
<b>Type</b>	R					R	R	R

Reset value = 0000 0110

Bit	Name	Function
7:3	Reserved	<b>Reserved.</b>
2	LOS2_INT	<b>LOS2_INT.</b> Indicates the LOS status on CKIN2. 0: Normal operation. 1: Internal loss-of-signal alarm on CKIN2 input.
1	LOS1_INT	<b>LOS1_INT.</b> Indicates the LOS status on CKIN1. 0: Normal operation. 1: Internal loss-of-signal alarm on CKIN1 input.
0	LOSX_INT	<b>LOSX_INT.</b> Indicates the LOS status of the external reference on the XA/XB pins. 0: Normal operation. 1: Internal loss-of-signal alarm on XA/XB reference clock input.

## Register 130.

Bit	D7	D6	D5	D4	D3	D2	D1	D0
<b>Name</b>	CLAT-PROGRESS	DIGHOLD-VALID	Reserved			FOS2_INT	FOS1_INT	LOL_INT
<b>Type</b>	R	R	R			R	R	R

Reset value = 0000 0001

Bit	Name	Function
7	CLAT-PROGRESS	<b>CLAT Progress.</b> Indicates if the last change in the CLAT register has been processed. 0: Coarse skew adjustment not in progress. 1: Coarse skew adjustment in progress.
6	DIGHOLD-VALID	<b>Digital Hold Valid.</b> Indicates if the digital hold circuit has enough samples of a valid clock to meet digital hold specifications. 0: Indicates digital hold history registers have not been filled. The digital hold output frequency may not meet specifications. 1: Indicates digital hold history registers have been filled. The digital hold output frequency is valid.
5:3	Reserved	<b>Reserved.</b>
2	FOS2_INT	<b>CKIN2 Frequency Offset Status.</b> 0: Normal operation. 1: Internal frequency offset alarm on CKIN2 input.
1	FOS1_INT	<b>CKIN1 Frequency Offset Status.</b> 0: Normal operation. 1: Internal frequency offset alarm on CKIN1 input.
0	LOL_INT	<b>PLL Loss of Lock Status.</b> 0: PLL locked. 1: PLL unlocked.

**Register 131.**

Bit	D7	D6	D5	D4	D3	D2	D1	D0
<b>Name</b>	Reserved					LOS2_FLG	LOS1_FLG	LOSX_FLG
<b>Type</b>	R					R/W	R/W	R/W

Reset value = 0001 1111

Bit	Name	Function
7:3	Reserved	<b>Reserved.</b>
2	LOS2_FLG	<b>CKIN2 Loss-of-Signal Flag.</b> 0: Normal operation. 1: Held version of LOS2_INT. Generates active output interrupt if output interrupt pin is enabled (INT_PIN = 1) and if not masked by LOS2_MSK bit. Flag cleared by writing 0 to this bit.
1	LOS1_FLG	<b>CKIN1 Loss-of-Signal Flag.</b> 0: Normal operation 1: Held version of LOS1_INT. Generates active output interrupt if output interrupt pin is enabled (INT_PIN = 1) and if not masked by LOS1_MSK bit. Flag cleared by writing 0 to this bit.
0	LOSX_FLG	<b>External Reference (signal on pins XA/XB) Loss-of-Signal Flag.</b> 0: Normal operation 1: Held version of LOSX_INT. Generates active output interrupt if output interrupt pin is enabled (INT_PIN = 1) and if not masked by LOSX_MSK bit. Flag cleared by writing 0 to this bit.

## Register 132.

Bit	D7	D6	D5	D4	D3	D2	D1	D0
Name	Reserved				FOS2_FLG	FOS1_FLG	LOL_FLG	Reserved
Type	R				R/W	R/W	R/W	R

Reset value = 0000 0010

Bit	Name	Function
7:4	Reserved	<b>Reserved.</b>
3	FOS2_FLG	<b>CLKIN_2 Frequency Offset Flag.</b> 0: Normal operation. 1: Held version of FOS2_INT. Generates active output interrupt if output interrupt pin is enabled (INT_PIN = 1) and if not masked by FOS2_MSK bit. Flag cleared by writing 0 to this bit.
2	FOS1_FLG	<b>CLKIN_1 Frequency Offset Flag.</b> 0: Normal operation 1: Held version of FOS1_INT. Generates active output interrupt if output interrupt pin is enabled (INT_PIN = 1) and if not masked by FOS1_MSK bit. Flag cleared by writing 0 to this bit.
1	LOL_FLG	<b>PLL Loss of Lock Flag.</b> 0: PLL locked 1: Held version of LOL_INT. Generates active output interrupt if output interrupt pin is enabled (INT_PIN = 1) and if not masked by LOL_MSK bit. Flag cleared by writing 0 to this bit.
0	Reserved	<b>Reserved.</b>

**Register 134.**

Bit	D7	D6	D5	D4	D3	D2	D1	D0
<b>Name</b>	PARTNUM_RO [11:4]							
<b>Type</b>	R							

Reset value = 0000 0001

Bit	Name	Function
7:0	PARTNUM_RO [11:0]	<b>Device ID (1 of 2).</b> 0000 0001 1010: Si5326

**Register 135.**

Bit	D7	D6	D5	D4	D3	D2	D1	D0
<b>Name</b>	PARTNUM_RO [3:0]				REVID_RO [3:0]			
<b>Type</b>	R				R			

Reset value = 1010 0010

Bit	Name	Function
7:4	PARTNUM_RO [11:0]	<b>Device ID (2 of 2).</b> 0000 0001 1010: Si5326
3:0	REVID_RO [3:0]	<b>Device Revision.</b> 0000: Revision A 0001: Revision B 0010: Revision C Others: Reserved

## Register 136.

Bit	D7	D6	D5	D4	D3	D2	D1	D0
<b>Name</b>	RST_REG	ICAL	Reserved					
<b>Type</b>	R/W	R/W	R					

Reset value = 0000 0000

Bit	Name	Function
7	RST_REG	<p><b>Internal Reset (Same as Pin Reset).</b></p> <p><b>Note:</b> The I<sup>2</sup>C (or SPI) port may not be accessed until 10 ms after RST_REG is asserted.</p> <p>0: Normal operation. 1: Reset of all internal logic. Outputs disabled or tristated during reset.</p>
6	ICAL	<p><b>Start an Internal Calibration Sequence.</b></p> <p>For proper operation, the device must go through an internal calibration sequence. ICAL is a self-clearing bit. Writing a "1" to this location initiates an ICAL. The calibration is complete once the LOL alarm goes low.</p> <p>0: Normal operation. 1: Writing a "1" initiates internal self-calibration. Upon completion of internal self-calibration, LOL will go low.</p> <p><b>Notes:</b></p> <ol style="list-style-type: none"> <li>1. A valid stable clock (within 100 ppm) must be present to begin ICAL.</li> <li>2. If the input changes by more than 500 ppm, the part may do an autonomous ICAL.</li> <li>3. See Table 9, "Register Locations Requiring ICAL," on page 63 for register changes that require an ICAL.</li> </ol>
5:0	Reserved	<b>Reserved.</b>

**Register 138.**

Bit	D7	D6	D5	D4	D3	D2	D1	D0
Name	Reserved						LOS2_EN [1:1]	LOS1_EN [1:1]
Type	R						R/W	R/W

Reset value = 0000 1111

Bit	Name	Function
7:2	Reserved	<b>Reserved.</b>
1	LOS2_EN [1:0]	<p><b>Enable CKIN2 LOS Monitoring on the Specified Input (2 of 2).</b></p> <p><b>Note:</b> LOS2_EN is split between two registers.            00: Disable LOS monitoring            01: Reserved            10: Enable LOSA monitoring            11: Enable LOS monitoring            LOSA is a slower and less sensitive version of LOS. See the Si53xx Family Reference Manual for details.</p>
0	LOS1_EN [1:0]	<p><b>Enable CKIN1 LOS Monitoring on the Specified Input (1 of 2).</b></p> <p><b>Note:</b> LOS1_EN is split between two registers.            00: Disable LOS monitoring            01: Reserved            10: Enable LOSA monitoring            11: Enable LOS monitoring            LOSA is a slower and less sensitive version of LOS. See the Si53xx Family Reference Manual for details.</p>

## Register 139.

Bit	D7	D6	D5	D4	D3	D2	D1	D0
<b>Name</b>	Reserved		LOS2_EN [0:0]	LOS1_EN [0:0]	Reserved		FOS2_EN	FOS1_EN
<b>Type</b>	R		R/W	R/W	R		R/W	R/W

Reset value = 1111 1111

Bit	Name	Function
7:6	Reserved	<b>Reserved.</b>
5	LOS2_EN [1:0]	<p><b>Enable CKIN2 LOS Monitoring on the Specified Input (2 of 2).</b></p> <p><b>Note:</b> LOS2_EN is split between two registers.            00: Disable LOS monitoring            01: Reserved            10: Enable LOSA monitoring            11: Enable LOS monitoring            LOSA is a slower and less sensitive version of LOS. See the Si53xx Family Reference Manual for details</p>
4	LOS1_EN [1:0]	<p><b>Enable CKIN1 LOS Monitoring on the Specified Input (1 of 2).</b></p> <p><b>Note:</b> LOS1_EN is split between two registers.            00: Disable LOS monitoring            01: Reserved            10: Enable LOSA monitoring            11: Enable LOS monitoring            LOSA is a slower and less sensitive version of LOS. See the Si53xx Family Reference Manual for details.</p>
3:2	Reserved	<b>Reserved.</b>
1	FOS2_EN	<p><b>Enables FOS on a Per Channel Basis.</b></p> <p>0: Disable FOS monitoring            1: Enable FOS monitoring</p>
0	FOS1_EN	<p><b>Enables FOS on a Per Channel Basis.</b></p> <p>0: Disable FOS monitoring            1: Enable FOS monitoring</p>

**Register 142.**

Bit	D7	D6	D5	D4	D3	D2	D1	D0
<b>Name</b>	INDEPENDENTSKEW1 [7:0]							
<b>Type</b>	R/W							

Reset value = 0000 0000

Bit	Name	Function
7:0	INDEPENDENTSKEW1 [7:0]	<b>INDEPENDENTSKEW1.</b> Eight-bit field that represents a 2's complement of the phase offset in terms of clocks from the high speed output divider.

**Register 143.**

Bit	D7	D6	D5	D4	D3	D2	D1	D0
<b>Name</b>	INDEPENDENTSKEW2 [7:0]							
<b>Type</b>	R/W							

Reset value = 0000 0000

Bit	Name	Function
7:0	INDEPENDENTSKEW2 [7:0]	<b>INDEPENDENTSKEW2.</b> Eight-bit field that represents a 2's complement of the phase offset in terms of clocks from the high speed output divider.

## 7. Pin Descriptions: Si5326

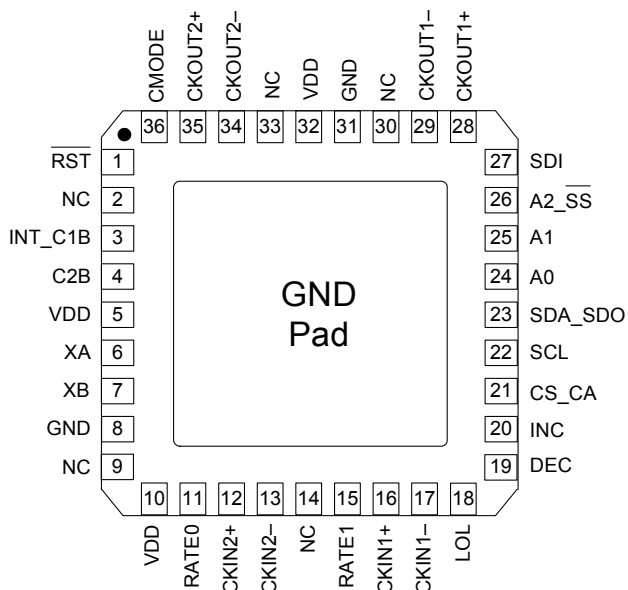

Pin #	Pin Name	I/O	Signal Level	Description
1	$\overline{\text{RST}}$	I	LVC MOS	<b>External Reset.</b> Active low input that performs external hardware reset of device. Resets all internal logic to a known state and forces the device registers to their default value. Clock outputs are tristated during reset. The part must be programmed after a reset or power on to get a clock output. See the Si53xx Family Reference Manual for details. This pin has a weak pull-up.
2, 9, 14, 30, 33	NC	—	—	<b>No Connection.</b> Leave floating. Make no external connections to this pin for normal operation.
3	INT_C1B	O	LVC MOS	<b>Interrupt/CKIN1 Invalid Indicator.</b> This pin functions as a device interrupt output or an alarm output for CKIN1. If used as an interrupt output, <i>INT_PIN</i> must be set to 1. The pin functions as a maskable interrupt output with active polarity controlled by the <i>INT_POL</i> register bit. If used as an alarm output, the pin functions as a LOS (and optionally FOS) alarm indicator for CKIN1. Set <i>CK1_BAD_PIN</i> = 1 and <i>INT_PIN</i> = 0. 0 = CKIN1 present 1 = LOS (FOS) on CKIN1 The active polarity is controlled by <i>CK_BAD_POL</i> . If no function is selected, the pin tristates.
<b>Note:</b> Internal register names are indicated by underlined italics, e.g., <i>INT_PIN</i> . See Section “5.Register Map”.				

Pin #	Pin Name	I/O	Signal Level	Description						
4	C2B	O	LVC MOS	<p><b>CKIN2 Invalid Indicator.</b></p> <p>This pin functions as a LOS (and optionally FOS) alarm indicator for CKIN2 if <math>CK2\_BAD\_PIN = 1</math>.</p> <p>0 = CKIN2 present 1 = LOS (FOS) on CKIN2</p> <p>The active polarity can be changed by <math>CK\_BAD\_POL</math>. If <math>CK2\_BAD\_PIN = 0</math>, the pin tristates.</p>						
5, 10, 32	V <sub>DD</sub>	V <sub>DD</sub>	Supply	<p><b>Supply.</b></p> <p>The device operates from a 1.8, 2.5, or 3.3 V supply. Bypass capacitors should be associated with the following V<sub>DD</sub> pins:</p> <table> <tr> <td>5</td> <td>0.1 μF</td> </tr> <tr> <td>10</td> <td>0.1 μF</td> </tr> <tr> <td>32</td> <td>0.1 μF</td> </tr> </table> <p>A 1.0 μF should also be placed as close to the device as is practical.</p>	5	0.1 μF	10	0.1 μF	32	0.1 μF
5	0.1 μF									
10	0.1 μF									
32	0.1 μF									
7 6	XB XA	I	Analog	<p><b>External Crystal or Reference Clock.</b></p> <p>External crystal should be connected to these pins to use internal oscillator based reference. Refer to the Si53xx Family Reference Manual for interfacing to an external reference. External reference must be from a high-quality clock source (TCXO, OCXO). Frequency of crystal or external clock is set by RATE[1:0] pins.</p>						
8, 31	GND	GND	Supply	<p><b>Ground.</b></p> <p>Must be connected to system ground. Minimize the ground path impedance for optimal performance of this device. Grounding these pins does not eliminate the requirement to ground the GND PAD on the bottom of the package.</p>						
11 15	RATE0 RATE1	I	3-Level	<p><b>External Crystal or Reference Clock Rate.</b></p> <p>Three level inputs that select the type and rate of external crystal or reference clock to be applied to the XA/XB port. Refer to the Si53xx Family Reference Manual for settings. These pins have both a weak pull-up and a weak pull-down; they default to M.</p> <p>L setting corresponds to ground. M setting corresponds to <math>V_{DD}/2</math>. H setting corresponds to <math>V_{DD}</math>.</p> <p><b>Note:</b> Tying the corresponding Rate<sub>n</sub> pins to HH (<math>V_{DD}</math>) provides compatibility to Si5325. Refer to Si5325 data sheet for operating in this mode.</p> <p>Some designs may require an external resistor voltage divider when driven by an active device that will tristate.</p>						
16 17	CKIN1+ CKIN1–	I	Multi	<p><b>Clock Input 1.</b></p> <p>Differential input clock. This input can also be driven with a single-ended signal. Input frequency range is 2 kHz to 710 MHz.</p>						
12 13	CKIN2+ CKIN2–	I	Multi	<p><b>Clock Input 2.</b></p> <p>Differential input clock. This input can also be driven with a single-ended signal. Input frequency range is 2 kHz to 710 MHz.</p>						
<p><b>Note:</b> Internal register names are indicated by underlined italics, e.g., <i>INT_PIN</i>. See Section “5.Register Map”.</p>										

Pin #	Pin Name	I/O	Signal Level	Description
18	LOL	O	LVC MOS	<p><b>PLL Loss of Lock Indicator.</b></p> <p>This pin functions as the active high PLL loss of lock indicator if the LOL_PIN register bit is set to 1.</p> <p>0 = PLL locked 1 = PLL unlocked</p> <p>If <i>LOL_PIN</i> = 0, this pin will tristate. Active polarity is controlled by the <i>LOL_POL</i> bit. The PLL lock status will always be reflected in the <i>LOL_INT</i> read only register bit.</p>
19	DEC	I	LVC MOS	<p><b>Skew Decrement.</b></p> <p>A pulse on this pin decreases the input to output device skew by <math>1/f_{OSC}</math> (approximately 200 ps). There is no limit on the range of skew adjustment by this method.</p> <p>Pin control is enabled by setting <i>INCDEC_PIN</i> = 1. If <i>INCDEC_PIN</i> = 0, this pin is ignored and output skew is controlled via the <i>CLAT</i> register.</p> <p>If both INC and DEC are tied high, phase buildout is disabled and the device maintains a fixed-phase relationship between the selected input clock and the output clock during an input clock switch.</p> <p>See the Si53xx Family Reference Manual for more details.</p> <p>This pin has a weak pull-down.</p>
20	INC	I	LVC MOS	<p><b>Skew Increment.</b></p> <p>A pulse on this pin increases the input to output device skew by <math>1/f_{OSC}</math> (approximately 200 ps). There is no limit on the range of skew adjustment by this method.</p> <p>Pin control is enabled by setting <i>INCDEC_PIN</i> = 1. If <i>INCDEC_PIN</i> = 0, this pin is ignored and output skew is controlled via the <i>CLAT</i> register.</p> <p>If both INC and DEC are tied high, phase buildout is disabled and the device maintains a fixed-phase relationship between the selected input clock and the output clock during an input clock switch.</p> <p>See the Si53xx Family Reference Manual for more details.</p> <p><b>Note:</b> INC does not increase skew if <i>NI_HS</i> = 4.</p> <p>This pin has a weak pull-down.</p>
<p><b>Note:</b> Internal register names are indicated by underlined italics, e.g., <i>INT_PIN</i>. See Section “5.Register Map”.</p>				

Pin #	Pin Name	I/O	Signal Level	Description
21	CS_CA	I/O	LVC MOS	<p><b>Input Clock Select/Active Clock Indicator.</b></p> <p><b>Input:</b> In manual clock selection mode, this pin functions as the manual input clock selector if the <i>CKSEL_PIN</i> is set to 1.  0 = Select CKIN1  1 = Select CKIN2  If <i>CKSEL_PIN</i> = 0, the <i>CKSEL_REG</i> register bit controls this function and this input tristates. If configured for input, must be tied high or low.</p> <p><b>Output:</b> In automatic clock selection mode, this pin indicates which of the two input clocks is currently the active clock. If alarms exist on both clocks, CK_ACTV will indicate the last active clock that was used before entering the digital hold state. The <i>CK_ACTV_PIN</i> register bit must be set to 1 to reflect the active clock status to the CK_ACTV output pin.  0 = CKIN1 active input clock  1 = CKIN2 active input clock  If <i>CK_ACTV_PIN</i> = 0, this pin will tristate. The CK_ACTV status will always be reflected in the <i>CK_ACTV_REG</i> read only register bit.</p>
22	SCL	I	LVC MOS	<p><b>Serial Clock.</b></p> <p>This pin functions as the serial clock input for both SPI and I<sup>2</sup>C modes.  This pin has a weak pull-down.</p>
23	SDA_SDO	I/O	LVC MOS	<p><b>Serial Data.</b></p> <p>In I<sup>2</sup>C control mode (CMODE = 0), this pin functions as the bidirectional serial data port.  In SPI control mode (CMODE = 1), this pin functions as the serial data output.</p>
25 24	A1 A0	I	LVC MOS	<p><b>Serial Port Address.</b></p> <p>In I<sup>2</sup>C control mode (CMODE = 0), these pins function as hardware controlled address bits. The I<sup>2</sup>C address is 1101 [A2] [A1] [A0].  In SPI control mode (CMODE = 1), these pins are ignored.  These pins have a weak pull-down.</p>
26	A2_SS	I	LVC MOS	<p><b>Serial Port Address/Slave Select.</b></p> <p>In I<sup>2</sup>C control mode (CMODE = 0), this pin functions as a hardware controlled address bit [A2].  In SPI control mode (CMODE = 1), this pin functions as the slave select input.  This pin has a weak pull-down.</p>
27	SDI	I	LVC MOS	<p><b>Serial Data In.</b></p> <p>In I<sup>2</sup>C control mode (CMODE = 0), this pin is ignored.  In SPI control mode (CMODE = 1), this pin functions as the serial data input.  This pin has a weak pull-down.</p>
<p><b>Note:</b> Internal register names are indicated by underlined italics, e.g., <i>INT_PIN</i>. See Section "5.Register Map".</p>				

# Si5326

Pin #	Pin Name	I/O	Signal Level	Description
29 28	CKOUT1– CKOUT1+	O	Multi	<b>Output Clock 1.</b> Differential output clock with a frequency range of 2 kHz to 1.4 GHz. Output signal format is selected by <i>SFOUT1_REG</i> register bits. Output is differential for LVPECL, LVDS, and CML compatible modes. For CMOS format, both output pins drive identical single-ended clock outputs.
34 35	CKOUT2– CKOUT2+	O	Multi	<b>Output Clock 2.</b> Differential output clock with a frequency range of 2 kHz to 1.4 GHz. Output signal format is selected by <i>SFOUT2_REG</i> register bits. Output is differential for LVPECL, LVDS, and CML compatible modes. For CMOS format, both output pins drive identical single-ended clock outputs.
36	CMODE	I	LVC MOS	<b>Control Mode.</b> Selects I <sup>2</sup> C or SPI control mode for the Si5326. 0 = I <sup>2</sup> C Control Mode 1 = SPI Control Mode This pin must not be NC. Tie either high or low. See the Si53xx Family Reference Manual for details on I <sup>2</sup> C or SPI operation.
GND PAD	GND	GND	Supply	<b>Ground Pad.</b> The ground pad must provide a low thermal and electrical impedance to a ground plane.
<b>Note:</b> Internal register names are indicated by underlined italics, e.g., <i>INT_PIN</i> . See Section “5.Register Map”.				

Table 9 lists all of the register locations that should be followed by an ICAL after their contents are changed.

**Table 9. Register Locations Requiring ICAL**

Addr	Register
0	BYPASS_REG
0	CKOUT_ALWAYS_ON
1	CK_PRIOR2
1	CK_PRIOR1
2	BWSEL_REG
4	HIST_DEL
5	ICMOS
7	FOSREFSEL
9	HIST_AVG
10	DSBL2_REG
10	DSBL1_REG
11	PD_CK2
11	PD_CK1
19	FOS_EN
19	FOS_THR
19	VALTIME
19	LOCKT
21	INCDEC_PIN
25	N1_HS
31	NC1_LS
34	NC2_LS
40	N2_HS
40	N2_LS
43	N31
46	N32
55	CLKIN2RATE
55	CLKIN1RATE

**Table 10. Si5326 Pull up/Pull down**

Pin #	Si5326	Pull up/ Pull down
1	$\overline{\text{RST}}$	U
11	RATE0	U, D
15	RATE1	U, D
19	DEC	D
20	INC	D
21	CS_CA	U, D
22	SCL	D
24	A0	D
25	A1	D
26	A2_SS	D
27	SDI	D
36	CMODE	U, D

## 8. Ordering Guide

Ordering Part Number	Output Clock Frequency Range	Package	ROHS6, Pb-Free	Temperature Range
Si5326A-C-GM	2 kHz–945 MHz 970–1134 MHz 1.213–1.4 GHz	36-Lead 6 x 6 mm QFN	Yes	–40 to 85 °C
Si5326B-C-GM	2 kHz–808 MHz	36-Lead 6 x 6 mm QFN	Yes	–40 to 85 °C
Si5326C-C-GM	2 kHz–346 MHz	36-Lead 6 x 6 mm QFN	Yes	–40 to 85 °C
Si5325/26-EVB		Evaluation Board		

**Note:** Add an R at the end of the device to denote tape and reel options.



## 10. Recommended PCB Layout

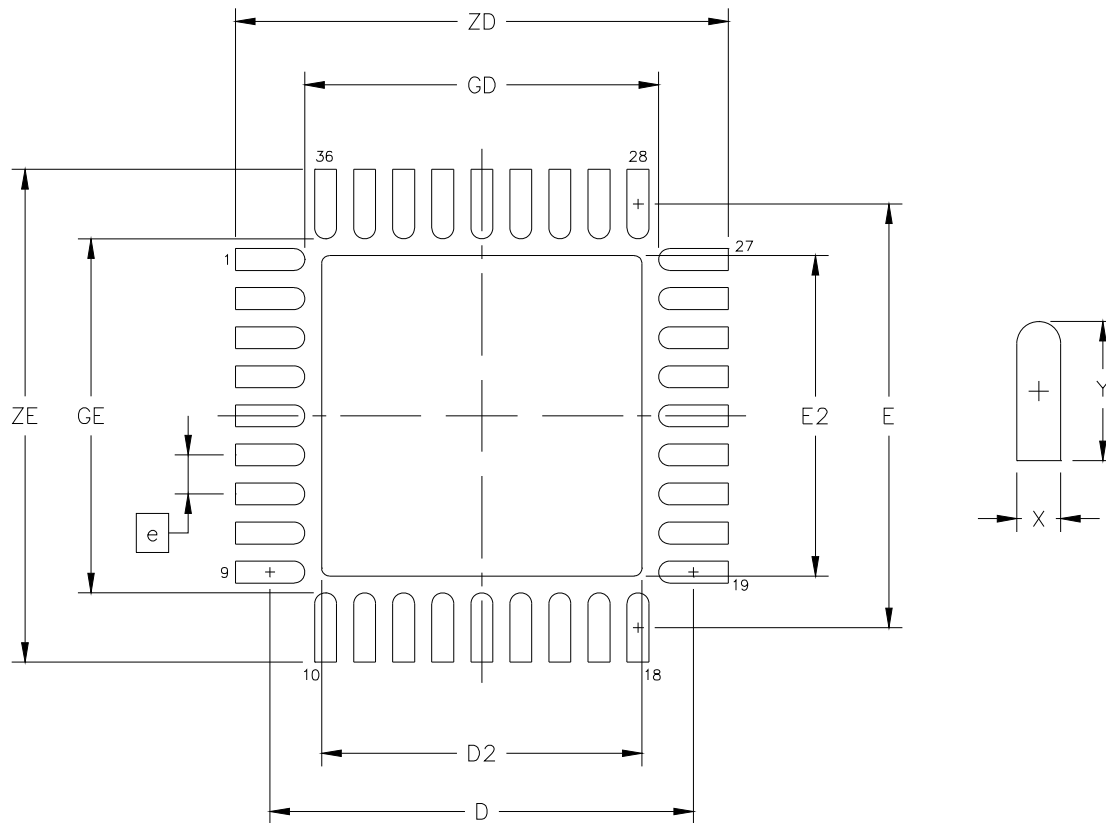

Figure 8. PCB Land Pattern Diagram

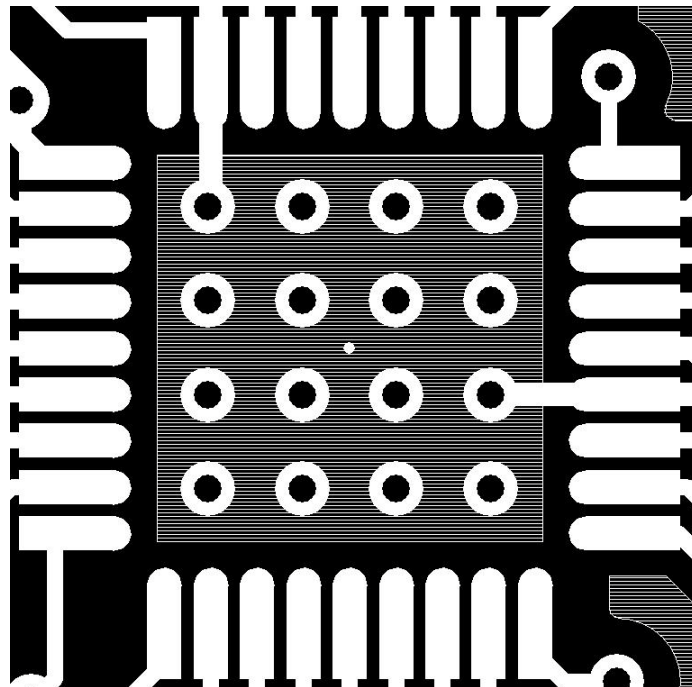

Figure 9. Ground Pad Recommended Layout

Table 12. PCB Land Pattern Dimensions

Dimension	MIN	MAX
e	0.50 BSC.	
E	5.42 REF.	
D	5.42 REF.	
E2	4.00	4.20
D2	4.00	4.20
GE	4.53	—
GD	4.53	—
X	—	0.28
Y	0.89 REF.	
ZE	—	6.31
ZD	—	6.31
<p><b>Notes (General):</b></p> <ol style="list-style-type: none"> <li>All dimensions shown are in millimeters (mm) unless otherwise noted.</li> <li>Dimensioning and Tolerancing is per the ANSI Y14.5M-1994 specification.</li> <li>This Land Pattern Design is based on IPC-SM-782 guidelines.</li> <li>All dimensions shown are at Maximum Material Condition (MMC). Least Material Condition (LMC) is calculated based on a Fabrication Allowance of 0.05 mm.</li> </ol> <p><b>Notes (Solder Mask Design):</b></p> <ol style="list-style-type: none"> <li>All metal pads are to be non-solder mask defined (NSMD). Clearance between the solder mask and the metal pad is to be 60 <math>\mu\text{m}</math> minimum, all the way around the pad.</li> </ol> <p><b>Notes (Stencil Design):</b></p> <ol style="list-style-type: none"> <li>A stainless steel, laser-cut, and electro-polished stencil with trapezoidal walls should be used to assure good solder paste release.</li> <li>The stencil thickness should be 0.125 mm (5 mils).</li> <li>The ratio of stencil aperture to land pad size should be 1:1 for the perimeter pads.</li> <li>A 4 x 4 array of 0.80 mm square openings on 1.05 mm pitch should be used for the center ground pad.</li> </ol> <p><b>Notes (Card Assembly):</b></p> <ol style="list-style-type: none"> <li>A No-Clean, Type-3 solder paste is recommended.</li> <li>The recommended card reflow profile is per the JEDEC/IPC J-STD-020C specification for Small Body Components.</li> </ol>		

## 11. Si5326 Device Top Mark



<b>Mark Method:</b>	Laser	
<b>Font Size:</b>	0.80 mm Right-Justified	
<b>Line 1 Marking:</b>	Si5326Q	Customer Part Number Q = Speed Code: A, B, C See Ordering Guide for options
<b>Line 2 Marking:</b>	C-GM	C = Product Revision G = Temperature Range –40 to 85 °C (RoHS6) M = QFN Package
<b>Line 3 Marking:</b>	YYWWRF	YY = Year WW = Work Week R = Die Revision F = Internal code Assigned by the Assembly House. Corresponds to the year and work week of the mold date.
<b>Line 4 Marking:</b>	Pin 1 Identifier	Circle = 0.75 mm Diameter Lower-Left Justified
	XXXX	Internal Code

## DOCUMENT CHANGE LIST

### Revision 0.1 to Revision 0.2

- Updated LVTTTL to LVCMOS is Table 2, “Absolute Maximum Ratings,” on page 6.
- Added Figure 3, “Typical Phase Noise Plot,” on page 16.
- Updated Figure 4, “Si5326 Typical Application Circuit (I<sup>2</sup>C Control Mode),” and Figure 5, “Si5326 Typical Application Circuit (SPI Control Mode),” on page 17 to show preferred external reference interface.
- Updated “5.Register Map”.
  - Added RATE0 and changed RATE to RATE1 and expanded RATE[1:0] description.
  - Changed font of register names to underlined italics.
- Updated “8. Ordering Guide” on page 65.
- Added “9. Package Outline: 36-Pin QFN” on page 66.
- Added “10.Recommended PCB Layout”.

### Revision 0.2 to Revision 0.3

- Changed 1.8 V operating range to ±5%.
- Updated Table 1 on page 4.
- Updated Table 2 on page 6.
- Updated Table 11 on page 66.
- Added table under Figure 3 on page 16.
- Updated “4. Functional Description” on page 18.
- Clarified “5. Register Map” on page 20 including pull-up/pull-down.

### Revision 0.3 to Revision 0.4

- Updated Table 1 on page 4.
- Added “11. Si5326 Device Top Mark” on page 69.

### Revision 0.4 to Revision 0.41

- Changed “latency” to “skew” throughout.
- Updated Table 1 on page 4.
  - Updated Thermal Resistance Junction to Ambient typical specification.
- Updated Figure 4 on page 17.
- Updated Figure 5, “Si5326 Typical Application Circuit (SPI Control Mode),” on page 17.
- Updated “5. Register Map” on page 20.
- Updated “9. Package Outline: 36-Pin QFN” on page 66.
- Added Figure 9, “Ground Pad Recommended Layout,” on page 67
- Added Register Map

### Revision 0.41 to Revision 0.42

- Text added to section “5. Register Map” on page 20.

### Revision 0.42 to Revision 0.43

- Replaced Figure 9.
- Updated Rise/Fall time values.

### Revision 0.43 to Revision 0.44

- Changed register address labels to decimal.

### Revision 0.44 to Revision 1.0

- Updated first page format to add chip image and pin out
- Updated Functional Block Diagram
- Updated Section “1.Electrical Specifications” to include ac/dc specifications from the Si53xx Family Reference Manual (FRM)
- Updated typical phase noise performance in Section “2.Typical Phase Noise Performance”
- Added INC/DEC pins to Figure 4 and Figure 5
- Clarified the format for FLAT [14:0]
- Added list of weak pull up/down resistors in Table 10, “Si5326 Pull up/Pull down,” on page 64
- Updated register maps 19, 20, 46, 47, 55, 142, 143, 185
- Added note to typical application circuits in Section “3.Typical Application Circuit”
- Added evaluation board part number to “8.Ordering Guide”
- Updated Section “11.Si5326 Device Top Mark”
- Updated Table 5, “Jitter Generation,” on page 14; filled in all TBDs, and lowered typical RMS values

NOTES:

## CONTACT INFORMATION

### Silicon Laboratories Inc.

400 West Cesar Chavez  
Austin, TX 78701  
Tel: 1+(512) 416-8500  
Fax: 1+(512) 416-9669  
Toll Free: 1+(877) 444-3032

Please visit the Silicon Labs Technical Support web page:  
<https://www.silabs.com/support/pages/contacttechnicalsupport.aspx>  
and register to submit a technical support request.

The information in this document is believed to be accurate in all respects at the time of publication but is subject to change without notice. Silicon Laboratories assumes no responsibility for errors and omissions, and disclaims responsibility for any consequences resulting from the use of information included herein. Additionally, Silicon Laboratories assumes no responsibility for the functioning of undescribed features or parameters. Silicon Laboratories reserves the right to make changes without further notice. Silicon Laboratories makes no warranty, representation or guarantee regarding the suitability of its products for any particular purpose, nor does Silicon Laboratories assume any liability arising out of the application or use of any product or circuit, and specifically disclaims any and all liability, including without limitation consequential or incidental damages. Silicon Laboratories products are not designed, intended, or authorized for use in applications intended to support or sustain life, or for any other application in which the failure of the Silicon Laboratories product could create a situation where personal injury or death may occur. Should Buyer purchase or use Silicon Laboratories products for any such unintended or unauthorized application, Buyer shall indemnify and hold Silicon Laboratories harmless against all claims and damages.

Silicon Laboratories, Silicon Labs, and DSPLL are trademarks of Silicon Laboratories Inc.  
Other products or brandnames mentioned herein are trademarks or registered trademarks of their respective holders.