

I²C-PROGRAMMABLE ANY-RATE, ANY-OUTPUT QUAD CLOCK GENERATOR

Features

- Low power MultiSynth technology enables independent, any-rate frequency synthesis on four differential output drivers
- Highly-configurable output drivers support up to four differential outputs or eight single-ended clock outputs or a combination of both
- Low phase jitter of 0.7 ps RMS typ
- High precision synthesis allows true zero ppm frequency accuracy on all outputs
- Flexible input reference:
 - External crystal: 8 to 30 MHz
 - CMOS input: 5 to 200 MHz
 - SSTL/HSTL input: 5 to 350 MHz
 - Differential input: 5 to 710 MHz
- Independently configurable outputs support any frequency or format:
 - LVPECL/LVDS: 0.16 to 710 MHz
 - HCSL: 0.16 to 250 MHz
 - CMOS: 0.16 to 200 MHz
 - SSTL/HSTL: 0.16 to 350 MHz
- Independent output voltage per driver: 1.5, 1.8, 2.5, or 3.3 V
- Single supply core with excellent PSRR: 1.8, 2.5, 3.3 V
- Independent Frequency increment/decrement feature enables glitchless frequency adjustments in 1 ppm steps
- Independent phase adjustment on each of the output drivers with an accuracy of ≤ 20 ps steps
- Highly configurable spread spectrum on any output:
 - Any frequency from 5 to 350 MHz
 - Any spread from 0.5 to 5.0%
 - Any modulation rate from 33 to 63 kHz
- External feedback mode allows zero-delay buffer implementation
- Loss of lock and loss of signal alarms
- I²C/SMBus compatible interface
- Easy to use programming software
- Small size: 4 x 4 mm, 24-QFN
- Low power: 45 mA core supply typ
- Wide temperature range: -40 to +85 °C

Applications

- Ethernet switch/router
- PCI Express 2.0
- Broadcast video/audio timing
- Processor and FPGA clocking
- Any-rate clock conversion
- MSAN/DSLAM/PON
- Fiber channel SAN
- Telecom line cards

Description

The Si5338 is a high-performance, low-jitter clock generator capable of synthesizing any frequency on each of the device's four output drivers. The device is capable of operating in asynchronous mode for replacing free-running crystal oscillators (XO) or in a synchronous mode for translating any frequency to any other frequency within its supported frequency range. Using its patented MultiSynth technology, the Si5338 allows generation of four independent clocks with 0 ppm precision. Each output clock is independently configurable to support any of the supported signal formats and supply voltages. The Si5338 provides low-jitter frequency synthesis with outstanding frequency flexibility in a space-saving 4 x 4 mm QFN package. The device is programmable via an I²C/SMBus-compatible serial interface and supports operation from a 1.8, 2.5, or 3.3 V core supply.

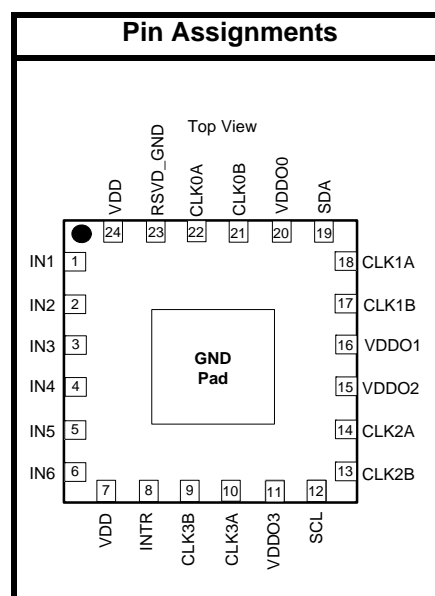

Functional Block Diagram

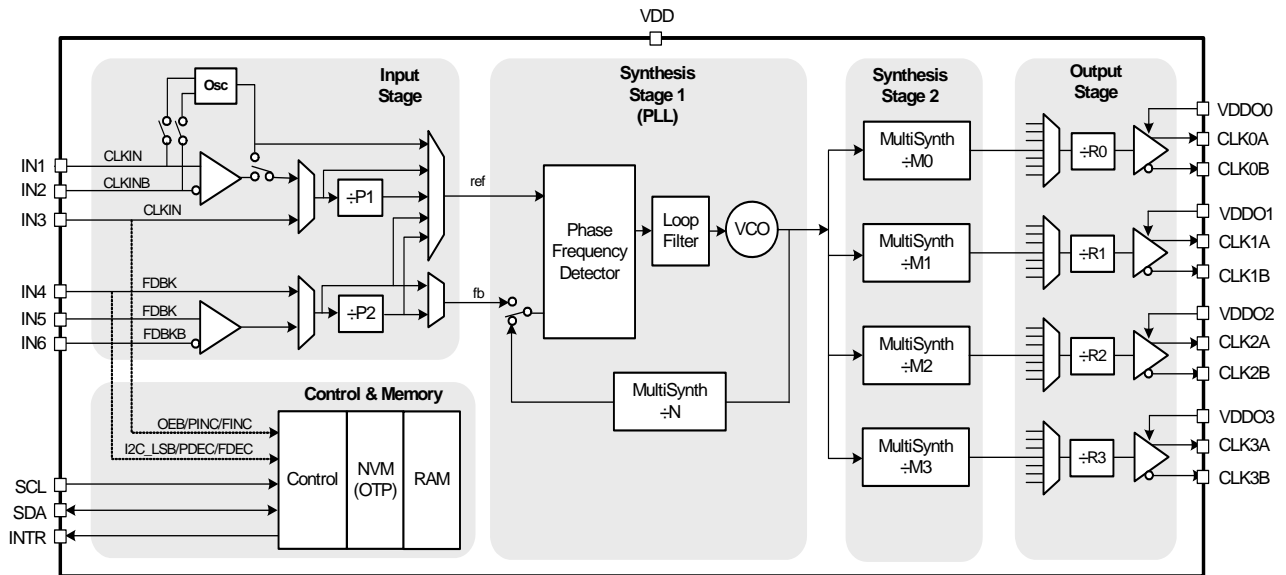

TABLE OF CONTENTS

<u>Section</u>	<u>Page</u>
1. Electrical Specifications	4
2. Typical Application Circuits	15
3. Functional Description	16
3.1. Overview	16
3.2. Input Stage	17
3.3. Synthesis Stages	17
3.4. Output Stage	18
3.5. Configuring the Si5338	18
3.6. Status Indicators	20
3.7. Output Enable	20
3.8. Features of the Si5338	21
4. Applications of the Si5338	22
4.1. Free-Running Clock Generator	22
4.2. Synchronous Frequency Translation	22
4.3. Configurable Buffer and Level Translator	23
5. I²C Interface	24
6. Pin Descriptions	25
7. Device Pinout by Part Number	29
8. Package Outline: 24-Lead QFN	31
9. Recommended PCB Layout	32
10. Ordering Information	33
Document Change List	34
Contact Information	36

1. Electrical Specifications

Table 1. Recommended Operating Conditions

($V_{DD} = 1.8\text{ V} -5\%$ to $+10\%$, $2.5\text{ V} \pm 10\%$, or $3.3\text{ V} \pm 10\%$, $T_A = -40$ to $85\text{ }^\circ\text{C}$)

Parameter	Symbol	Test Condition	Min	Typ	Max	Unit
Ambient Temperature	T_A		-40	25	85	$^\circ\text{C}$
Core Supply Voltage	V_{DD}		2.97	3.3	3.63	V
			2.25	2.5	2.75	V
			1.71	1.8	1.98	V
Output Buffer Supply Voltage	V_{DDOn}		1.4	—	3.63	V

Note: All minimum and maximum specifications are guaranteed and apply across the recommended operating conditions. Typical values apply at nominal supply voltages and an operating temperature of $25\text{ }^\circ\text{C}$ unless otherwise noted.

Table 2. Absolute Maximum Ratings

Parameter	Symbol	Test Condition	Value	Unit
DC Supply Voltage	V_{DD}		-0.5 to 3.8	V
Storage Temperature Range	T_{STG}		-55 to 150	$^\circ\text{C}$
ESD Tolerance		HBM (100 pF, 1.5 k Ω)	2.5	kV
ESD Tolerance		CDM	550	V
ESD Tolerance		MM	175	V
Latch-up Tolerance			JESD78 Compliant	

Note: Permanent device damage may occur if the Absolute Maximum Ratings are exceeded. Functional operation should be restricted to the conditions as specified in the operational sections of this data sheet. Exposure to absolute maximum rating conditions for extended periods may affect device reliability.

Table 3. Thermal Characteristics

Parameter	Symbol	Test Condition	Value	Unit
Thermal Resistance Junction to Ambient	θ_{JA}	Still Air	37	$^\circ\text{C/W}$
Thermal Resistance Junction to Case	θ_{JC}	Still Air	25	$^\circ\text{C/W}$

Table 4. DC Characteristics(V_{DD} = 1.8 V -5% to +10%, 2.5 V ±10%, or 3.3 V ±10%, T_A = -40 to 85 °C)

Parameter	Symbol	Test Condition	Min	Typ	Max	Unit
Core Supply Current*	I _{DD}	100 MHz on all outputs, 25 MHz refclk	—	45	60	mA
Output Buffer Supply Current	I _{DDOx}	LVPECL, 710 MHz	—	—	30	mA
		LVDS, 710 MHz	—	—	8	mA
		HCSL, 250 MHz 2 pF load capacitance	—	—	20	mA
		SSTL, 350 MHz	—	—	19	mA
		CMOS, 50 MHz 15 pF load capacitance	—	—	28	mA
		CMOS, 200 MHz 2 pF load capacitance	—	—	28	mA
		HSTL, 350 MHz	—	—	19	mA

***Note:** Output Supply Voltage = 3.63 V. The supply current is considerably lower for lower supply voltage.

Table 5. Performance Characteristics(V_{DD} = 1.8 V -5% to +10%, 2.5 V ±10%, or 3.3 V ±10%, T_A = -40 to 85 °C)

Parameter	Symbol	Test Condition	Min	Typ	Max	Unit
PLL Acquisition Time	t _{ACQ}		—	—	25	ms
PLL Lock Range	f _{LOCK}		5000	—	—	ppm
PLL Loop Bandwidth	f _{BW}		—	1.6	—	MHz
MultiSynth Frequency Synthesis Resolution	f _{RES}	Output frequency ≤ F _{vco} /8	0	0	1	ppb
CLKIN Loss of Signal Detect Time	t _{LOS}		—	2.6	5	μs
CLKIN Loss of Signal Release Time	t _{LOSRLS}		0.01	0.2	1	μs
PLL Loss of Lock Detect Time	t _{LOL}	Clock multiplication ratio off by 1000 ppm	—	5	10	ms
Reset Time	t _{RST}		—	—	2	ms
POR to Output Clock Valid (Pre-programmed Devices)	t _{RDY}		—	—	2	ms
Input-to-Output Propagation Delay	t _{PROP}	Buffer Mode (PLL Bypass)	—	2.5	—	ns
Output-Output Skew	t _{DSKEW}	Outputs at same frequency, signal format	—	—	100	ps
Programmable Initial Phase Offset	P _{OFFSET}		-45	—	+45	ns
Phase Increment/Decrement Accuracy	P _{STEP}		—	—	20	ps
Phase Increment/Decrement Range	P _{RANGE}		-45	—	+45	ns
Frequency range for phase increment/decrement	f _{PRANGE}		—	—	350 ¹	MHz
Phase Increment/Decrement Update Rate	P _{UPDATE}	Pin control ^{2,3}	—	—	1500	kHz
Frequency Increment/Decrement Step Size	f _{STEP}	R divider not used	1	—	See Note ¹	ppm

Notes:

1. Keep MultiSynth output frequency between 5 MHz to F_{vco}/8.
2. Maximum frequency is F_{vco}/8.
3. Update rate via I²C is limited by the time it takes to perform a write operation.
4. Default value is 5% down spread.
5. Default value is ~31.5 kHz

Table 5. Performance Characteristics (Continued) $(V_{DD} = 1.8\text{ V } -5\% \text{ to } +10\%, 2.5\text{ V } \pm 10\%, \text{ or } 3.3\text{ V } \pm 10\%, T_A = -40 \text{ to } 85\text{ }^\circ\text{C})$

Parameter	Symbol	Test Condition	Min	Typ	Max	Unit
Frequency Increment/ Decrement Range	f_{RANGE}	R divider not used	5	—	350 ¹	MHz
Frequency Increment/ Decrement Update Rate	f_{UPDATE}	Pin control ^{1,2}	—	—	1500	kHz
Spread Spectrum PP Frequency Deviation	SS_{DEV}	MultiSynth Output $\leq \sim F_{\text{vco}}/8$	0.1	—	5.0 ⁴	%
Spread Spectrum Modulation Rate	SS_{DEV}	MultiSynth Output $\leq \sim F_{\text{vco}}/8$	30	—	63 ⁵	kHz
Notes:						
1. Keep MultiSynth output frequency between 5 MHz to $F_{\text{vco}}/8$.						
2. Maximum frequency is $F_{\text{vco}}/8$.						
3. Update rate via I ² C is limited by the time it takes to perform a write operation.						
4. Default value is 5% down spread.						
5. Default value is ~ 31.5 kHz						

Table 6. Input and Output Clock Characteristics $(V_{DD} = 1.8\text{ V } -5\% \text{ to } +10\%, 2.5\text{ V } \pm 10\%, \text{ or } 3.3\text{ V } \pm 10\%, T_A = -40 \text{ to } 85\text{ }^\circ\text{C})$

Parameter	Symbol	Test Condition	Min	Typ	Max	Units
Input Clock (AC Coupled Differential Input Clocks on Pins IN1/2, IN5/6)						
Frequency	f_{IN}		5	—	710	MHz
Differential Voltage Swing	V_{PP}	710 MHz input	0.4	—	2.4	V_{PP}
Rise/Fall Time	$t_{\text{R}}/t_{\text{F}}$	20%–80%	—	—	1.0	ns
Duty Cycle	DC	< 1 ns tr/tf	40	—	60	%
Input Impedance	R_{IN}		10	—	—	$k\Omega$
Input Capacitance	C_{IN}		—	3.5	—	pF
Input Clock (DC-Coupled Single-Ended Input Clock on Pins IN3/4)						
Frequency	f_{IN}	CMOS	5	—	200	MHz
		SSTL/HSTL	5	—	350	MHz
Input Voltage	V_{I}		–0.1	—	3.63	V _{pp}
Input Voltage Swing (CMOS Standard)		200 MHz, Tr/Tf = 1.3 ns	0.8	—	3.73	V
Rise/Fall Time	$t_{\text{R}}/t_{\text{F}}$	20%–80%	—	—	4	ns
Duty Cycle	DC	< 4 ns tr/tf	40	—	60	%
Input Capacitance	C_{IN}		—	2	—	pF

Table 6. Input and Output Clock Characteristics (Continued) $(V_{DD} = 1.8\text{ V} \pm 5\%$ to $+10\%$, $2.5\text{ V} \pm 10\%$, or $3.3\text{ V} \pm 10\%$, $T_A = -40$ to $85\text{ }^\circ\text{C}$)

Parameter	Symbol	Test Condition	Min	Typ	Max	Units
Output Clocks (Differential)						
Frequency	f_{OUT}	LVPECL, LVDS	0.16	—	350	MHz
			367	—	466	MHz
			550	—	710	MHz
		HCSL	0.16	—	250	MHz
LVPECL Output Voltage	V_{OC}	common mode	—	$V_{DDO} - 1.4\text{ V}$	—	V
	V_{SEPP}	peak-to-peak single-ended swing	0.55	0.8	0.96	V_{PP}
LVDS Output Voltage (2.5/3.3 V)	V_{OC}	common mode	1.125	1.2	1.275	V
	V_{SEPP}	peak-to-peak single-ended swing	0.25	0.35	0.45	V_{PP}
LVDS Output Voltage (1.8 V)	V_{OC}	common mode	0.8	0.875	0.95	V
	V_{SEPP}	peak-to-peak single-ended swing	0.25	0.35	0.45	V_{PP}
HCSL Output Voltage	V_{OC}	common mode	0.35	0.375	0.400	V
	V_{SEPP}	peak-to-peak single-ended swing	0.575	0.725	0.85	V_{PP}
Rise/Fall Time	t_R/t_F	20%–80%	—	—	450	ps
Duty Cycle	DC	$CK_n < 350\text{ MHz}$	45	—	55	%
		$350\text{ MHz} < CLK_n < 710\text{ MHz}$	40	—	60	%
Output Clocks (Single-Ended)						
Frequency	f_{OUT}	CMOS	0.16	—	200	MHz
		SSTL, HSTL	0.16	—	350	MHz
CMOS 20%-80% Rise/Fall Time	t_R/t_F	2 pF load	—	0.45	0.85	ns
CMOS 20%-80% Rise/Fall Time	t_R/t_F	15 pF load	—	—	1.7	ns
CMOS Output Resistance			—	50	—	Ω
SSTL Output Resistance			—	50	—	Ω
HSTL Output Resistance			—	50	—	Ω
CMOS Output Voltage	V_{OH}	4 mA load	$V_{DDO} - .3$	—		V
	V_{OL}	4 mA load		—	.3	V

Table 6. Input and Output Clock Characteristics (Continued) $(V_{DD} = 1.8\text{ V } -5\% \text{ to } +10\%, 2.5\text{ V } \pm 10\%, \text{ or } 3.3\text{ V } \pm 10\%, T_A = -40 \text{ to } 85\text{ }^\circ\text{C})$

Parameter	Symbol	Test Condition	Min	Typ	Max	Units
SSTL Output Voltage	V_{OH}	SSTL-3 $V_{DDOx} = 2.97$ to 3.63 V	$.45xV_{DDO}+.41$	—	—	V
	V_{OL}		—	—	$.45xV_{DDO}$ $-.41$	V
	V_{OH}	SSTL-2 $V_{DDOx} = 2.25$ to 2.75 V	$0.5xV_{DDO}+.41$	—	—	V
	V_{OL}		—	—	$0.5xV_{DDO}$ $-.41$	V
	V_{OH}	SSTL-18 $V_{DDOx} = 1.71$ to 1.98 V	$0.5xV_{DDO}+.34$	—	—	V
	V_{OL}		—	—	$0.5xV_{DDO}$ $-.34$	V
HSTL Output Voltage	V_{OH}	$V_{DDO} = 1.4 \text{ to } 1.6\text{ V}$	$0.5xV_{DDO} +.3$	—	—	V
	V_{OL}		—	—	$.5xV_{DDO}$ $-.3$	V
Duty Cycle	DC		45	—	55	%

Table 7. Control Pins

Parameter	Symbol	Condition	Typ	Max	Unit
Input Control Pins (IN3, IN4)					
Input Voltage Low	V_{IL}		-0.1	0.3	V
Input Voltage High	V_{IH}		0.9	3.63	V
Input Capacitance	C_{IN}		—	4	pF
Input Resistance	R_{IN}		20	—	k Ω
Output Control Pins (INTR)					
Output Voltage Low	V_{OL}	$I_{SINK} = 3 \text{ mA}$	0	0.4	V
Rise/Fall Time 20–80%	t_R/t_F	$C_L < 10 \text{ pf}$, pull up $\leq 1 \text{ k}\Omega$	—	10	ns

Table 8. Crystal Specifications for 8 to 11 MHz

Parameter	Symbol	Min	Typ	Max	Unit
Crystal Frequency	f_{XTAL}	8	—	11	MHz
Load Capacitance (on-chip differential)	C_L	11	12	13	pF
Crystal Output Capacitance	C_O	—	—	6	pF
Equivalent Series Resistance	r_{ESR}	—	—	300	Ω
Crystal Max Drive Level	d_L	100	—	—	μW

Table 9. Crystal Specifications for 11 to 19 MHz

Parameter	Symbol	Min	Typ	Max	Unit
Crystal Frequency	f_{XTAL}	11	—	19	MHz
Load Capacitance (on-chip differential)	C_L	11	12	13	pF
Crystal Output Capacitance	C_O	—	—	5	pF
Equivalent Series Resistance	r_{ESR}	—	—	200	Ω
Crystal Max Drive Level	d_L	100	—	—	μW

Table 10. Crystal Specifications for 19 to 26 MHz

Parameter	Symbol	Min	Typ	Max	Unit
Crystal Frequency	f_{XTAL}	19		26	MHz
Load Capacitance (on-chip differential)	C_L	11	12	13	pF
Crystal Output Capacitance	C_O			4	pF
Equivalent Series Resistance	r_{ESR}			100	Ω
Crystal Max Drive Level	d_L	100			μW

Table 11. Crystal Specifications for 26 to 30 MHz

Parameter	Symbol	Min	Typ	Max	Unit
Crystal Frequency	f_{XTAL}	26		30	MHz
Load Capacitance (on-chip differential)	C_L	11	12	13	pF
Crystal Output Capacitance	C_O			4	pF
Equivalent Series Resistance	r_{ESR}			75	Ω
Crystal Max Drive Level	d_L	100			μW

Table 12. Jitter Specifications¹(V_{DD} = 1.8 V -5% to +10%, 2.5 V ±10%, or 3.3 V ±10%, T_A = -40 to 85 °C)

Parameter	Symbol	Test Condition	Min	Typ	Max	Unit
GbE Random Jitter (12 kHz–20 MHz) ²	J _{GbE}	CLKIN = 25 MHz All CLK _n at 125 MHz ³	—	0.7	1	ps RMS
GbE Random Jitter (1.875–20 MHz)	R _{JGbE}	CLKIN = 25 MHz All CLK _n at 125 MHz ³	—	0.38	0.79	ps RMS
OC-12 Random Jitter (12 kHz–5 MHz)	J _{OC12}	CLKIN = 19.44 MHz All CLK _n at 155.52 MHz ³	—	0.7	1	ps RMS
PCI Express 3.0 Random Jitter (1.5 MHz–50 MHz) ²	J _{PCIERJ1}	CLKIN = 25 MHz All CLK _n at 100 MHz Spread Spectrum not enabled ³	—	0.6	1	ps RMS
PCI Express 3.0 Random Jitter (12 kHz–20 MHz) ²	J _{PCIERJ2}	CLKIN = 25 MHz All CLK _n at 100 MHz Spread Spectrum not enabled ³	—	0.7	1	ps RMS
PCI Express 3.0 Period Jitter		CLKIN = 25 MHz All CLK _n at 100 MHz Spread Spectrum not enabled ³	—	8	15	ps pk-pk
PCI Express 3.0 Cycle-Cycle Jitter		CLKIN = 25 MHz All CLK _n at 100 MHz Spread Spectrum not enabled ³	—	13	30	ps pk-pk
Period Jitter	J _{PER}	N = 10,000 cycles ⁴	—	10	30	ps pk-pk
Cycle-Cycle Jitter	J _{CC}	N = 10,000 cycles Output MultiSynth operated in Integer or Fractional mode. ⁴	—	17	50	ps pk-pk
Random Jitter (12 kHz–20 MHz)	R _J	Output and feedback MultiSynth in Integer or fractional mode ⁴	—	0.7	1.5	ps RMS

Notes:

1. All jitter measurements apply for LVDS/HCSL/LVPECL output format with a low noise differential input clock and are made with an Agilent 90804 oscilloscope. All RJ measurements use RJ/DJ separation.
2. D_J for PCI and GbE is < 5 ps pp
3. Output MultiSynth in Integer mode.
4. Input frequency ≥ 25 MHz and any output frequency ≥ 5 MHz.
5. R_J is multiplied by 14; estimate the pp jitter from R_J over 2¹² rising edges.

Table 12. Jitter Specifications¹ (Continued)(V_{DD} = 1.8 V -5% to +10%, 2.5 V ±10%, or 3.3 V ±10%, T_A = -40 to 85 °C)

Parameter	Symbol	Test Condition	Min	Typ	Max	Unit
Deterministic Jitter	D _J	Output MultiSynth operated in fractional mode ⁴	—	3	15	ps pk-pk
		Output MultiSynth operated in integer mode ⁴	—	2	10	ps pk-pk
Total Jitter (12 kHz–20 MHz)	T _J = D _J +14xR _J (See Note ⁵)	Output MultiSynth operated in fractional mode ⁴	—	13	36	ps pk-pk
		Output MultiSynth operated in integer mode ⁴	—	12	20	ps pk-pk
Notes:						
1. All jitter measurements apply for LVDS/HCSL/LVPECL output format with a low noise differential input clock and are made with an Agilent 90804 oscilloscope. All RJ measurements use RJ/DJ separation.						
2. D _J for PCI and GBE is < 5 ps pp						
3. Output MultiSynth in Integer mode.						
4. Input frequency ≥ 25 Mhz and any output frequency ≥ 5 MHz.						
5. R _j is multiplied by 14; estimate the pp jitter from R _j over 2 ¹² rising edges.						

Table 13. Typical Phase Noise Performance

Offset Frequency	25MHz XTAL to 156.25 MHz	27 MHz Ref In to 148.3517 MHz	19.44 MHz Ref In to 155.52 MHz	Units
100 Hz	-90	-87	-110	dBc/Hz
1 kHz	-120	-117	-116	
10 kHz	-126	-123	-123	
100 kHz	-132	-130	-128	
1 MHz	-132	-132	-128	
10 MHz	-145	-145	-145	

Table 14. I²C Specifications (SCL,SDA)¹

Parameter	Symbol	Test Condition	Standard Mode		Fast Mode ²		Unit
			Min	Max	Min	Max	
LOW Level Input Voltage	V _{IL} I2C		-0.5	0.3 x V _{DDI2C}	-0.5	0.3 x V _{DDI2C} ³	V
HIGH Level Input Voltage	V _{IH} I2C		0.7 x V _{DDI2C}	3.63	0.7 x V _{DDI2C} ³	3.63	V
Hysteresis of Schmitt Trigger Inputs	V _{HYS}		N/A	N/A	0.1	—	V
LOW Level Output Voltage (open drain or open collector) at 3 mA Sink Current	V _{OL} I2C ³	V _{DDI2C} ³ = 2.5/3.3 V	0	0.4	0	0.4	V
		V _{DDI2C} ³ = 1.8 V	N/A	N/A	0	0.2 x V _{DDI2C}	V
Input Current	I _I I2C		-10	10	-10	10	μA
Capacitance for each I/O Pin	C _I I2C	V _{IN} = -0.1 to V _{DDI2C}	—	4	—	4	pF
I ² C Bus Timeout	—	Timeout Enabled	25	35	25	35	ms

Notes:

1. Refer to NXP's UM10204 I²C-bus specification and user manual, Revision 03, for further details: www.nxp.com/acrobat_download/usermanuals/UM10204_3.pdf.
2. Compliant with Fast Mode+ pending characterization.
3. Only I²C pullup voltages (V_{DDI2C}) of 1.71 to 3.63 V are supported. Must write register 27[7] = 1 if the I²C bus voltage is less than 2.5 V to maintain compatibility with the I²C bus standard.

2. Typical Application Circuits

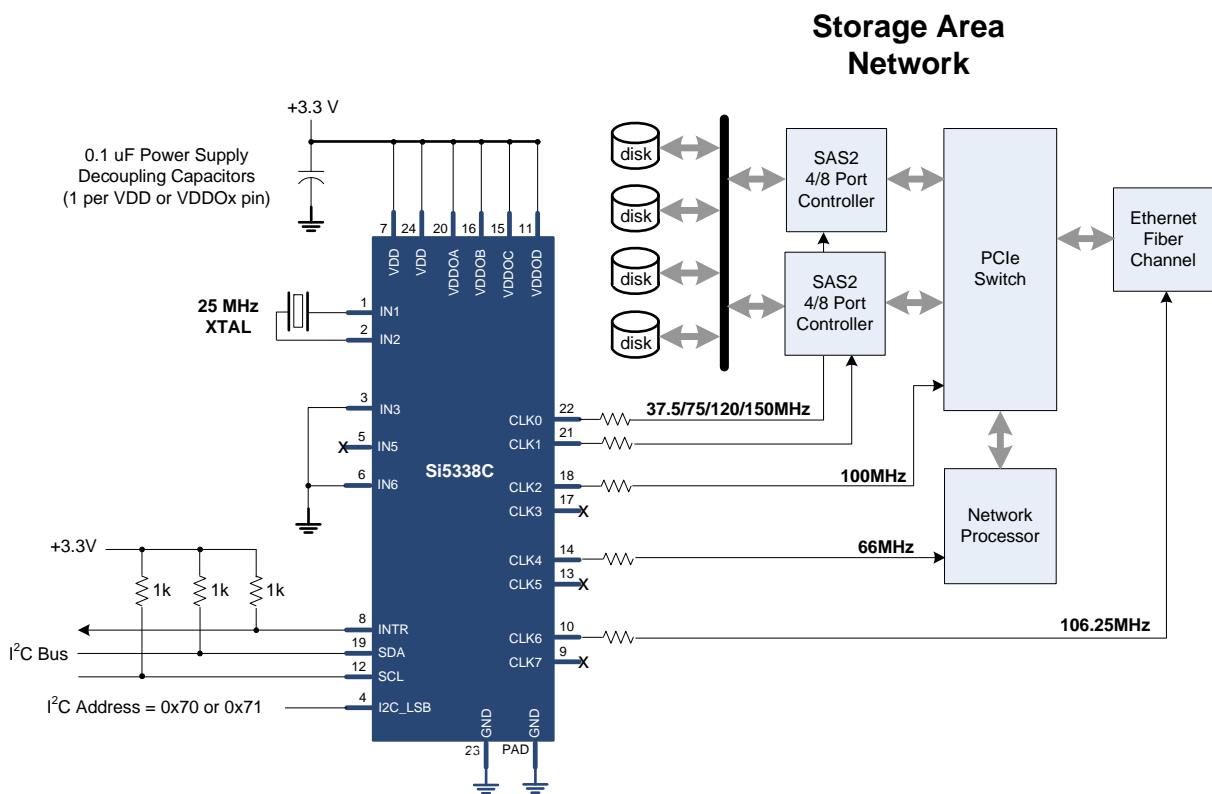
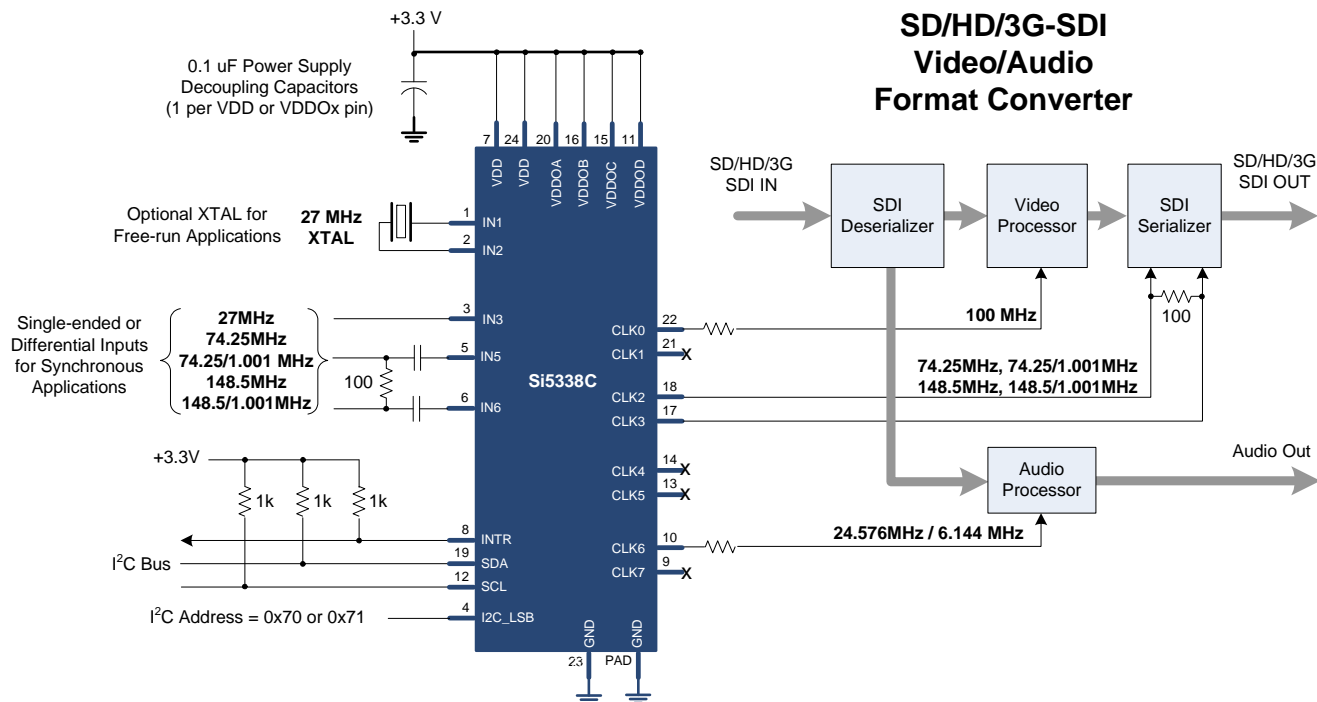

3. Functional Description

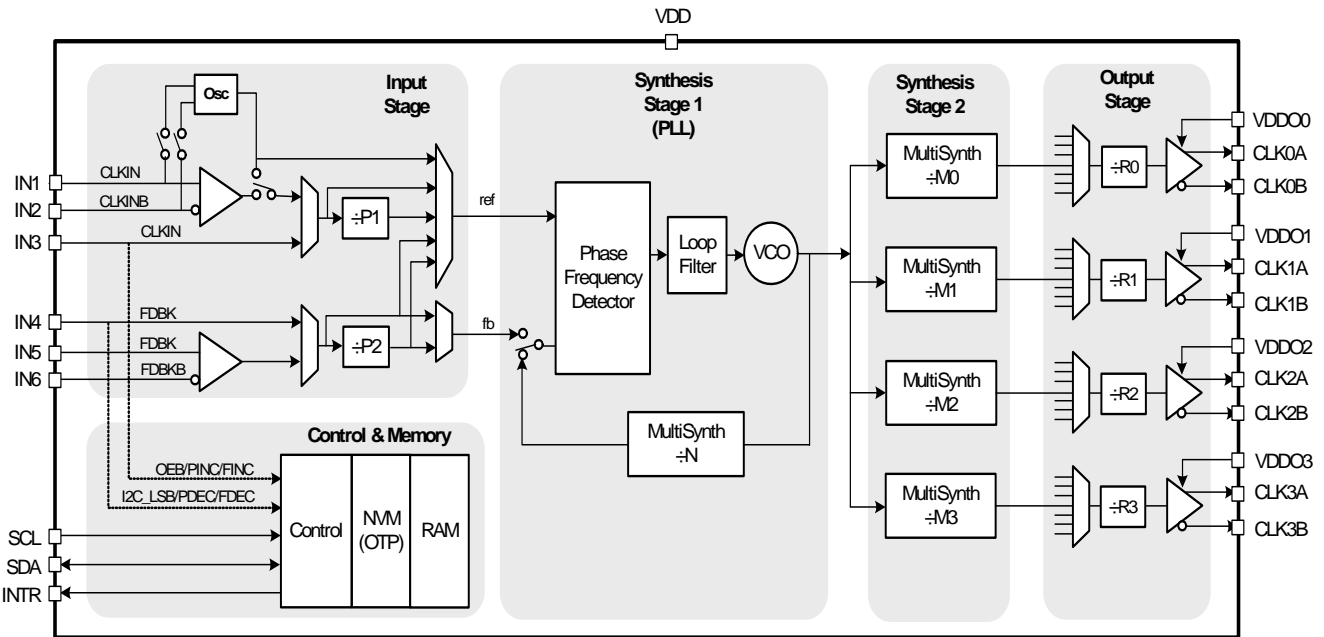

Figure 1. Si5338 Block Diagram

3.1. Overview

The Si5338 is a high-performance, low-jitter clock generator capable of synthesizing four independent user-programmable clock frequencies up to 350 MHz and select frequencies up to 710 MHz. The device supports free-run operation using an external crystal, or it can lock to an external clock for generating four synchronous clocks. The output drivers support four differential clocks or eight single-ended clocks or a combination of both. The output drivers are configurable to support common signal formats, such as LVPECL, LVDS, HCSL, CMOS, HSTL, and SSTL. Separate output supply pins are available for generating 3.3, 2.5, 1.8, and 1.5 V signal levels. The core voltage supply accepts 3.3, 2.5, or 1.8 V and is independent from the output supplies.

Using its two-stage synthesis architecture and patented high-resolution MultiSynth technology, the Si5338 can generate four independent frequencies from a single input frequency. In addition to clock generation, the inputs can bypass the synthesis stage enabling the Si5338 to be used as a high-performance clock buffer or a combination of a buffer and generator.

For applications that need fine frequency adjustments, such as clock margining, each of the synthesized frequencies can be incremented or decremented in user-defined steps as low as 1 ppm per step.

Output-to-output phase delays are also adjustable in user-defined steps as low as 20 ps per step to compensate for PCB trace delays or for fine tuning of setup and hold margins. A zero-delay buffer mode is also available to help minimize input-to-output delay. Spread spectrum is available on each of the clock outputs for EMI-sensitive applications, such as PCI Express.

Configuration and control of the Si5338 is mainly handled through the I²C/SMBus interface. Some features, such as output enable and frequency or phase adjustments, can optionally be pin controlled. The device has a maskable interrupt pin that can be monitored for loss of lock or loss of input signal conditions.

The device also provides the option of storing a user-definable clock configuration in its non-volatile memory (NVM), which becomes the default clock configuration at power-up. Changes to the default configuration can always be made through the I²C interface.

The Si5338 brings unprecedented flexibility and ease of use to high-performance clock generation and distribution applications.

3.2. Input Stage

The input stage supports four inputs. Two are used as the *clock inputs* to the synthesis stage, and the other two are used as *feedback inputs* for zero delay or external feedback mode. In cases where external feedback is not required, all four input are available to the synthesis stage. The *reference selector* selects one of the inputs as the reference to the synthesis stage. The input configuration is selectable through the I²C interface.

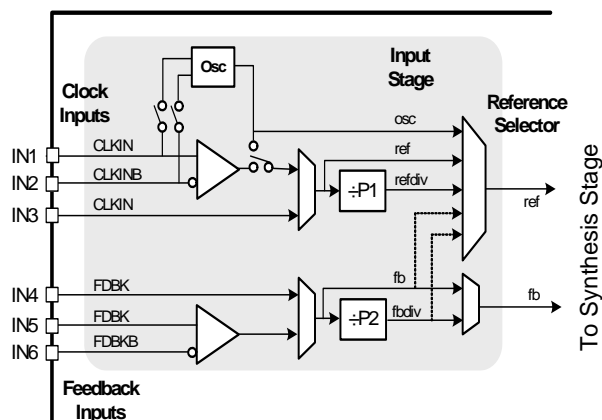

Figure 2. Input Stage

IN1/IN2 and IN5/IN6 are differential inputs capable of accepting clock rates from 5 to 710 MHz. The differential inputs are capable of interfacing to multiple signals, such as LVPECL, LVDS, HSCL, and CML. Differential signals must be ac-coupled as shown in Figure 3. A termination resistor of 100 Ω placed close to the input pins is also required. Refer to Table 6 for signal voltage limits.

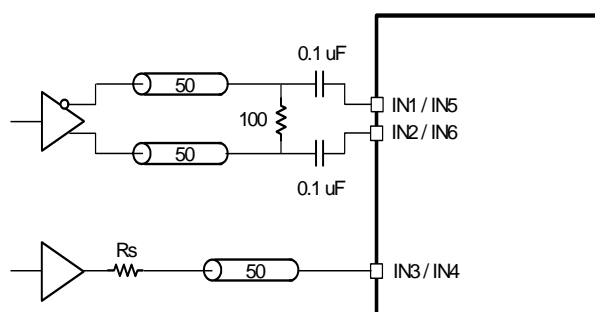

Figure 3. Interfacing Differential and Single-Ended Signals to the Si5338

IN3 and IN4 accept single-ended signals from 5 MHz to 200 MHz (CMOS) or 350 MHz (SSTL, HSTL). The single-ended inputs are internally ac-coupled; so, they can accept a wide variety of signals without requiring a specific dc level. The input signal only needs to meet a minimum voltage swing, which makes it compatible with common single-ended signals, such as CMOS, HSTL, and SSTL. Refer to Table 6 for signal voltage limits. A typical single-ended connection is shown in Figure 3. For additional termination options, refer to “AN408: Termination Options for Any-Rate, Any-Output Clock Generators and Clock Buffers—Si5338, Si5334, Si5330”.

For free-run operation, the internal oscillator can operate from a low-frequency fundamental mode crystal (XTAL) with a resonant frequency between 8 and 30 MHz. A crystal can easily be connected to pins IN1 and IN2 without external components as shown in Figure 4.

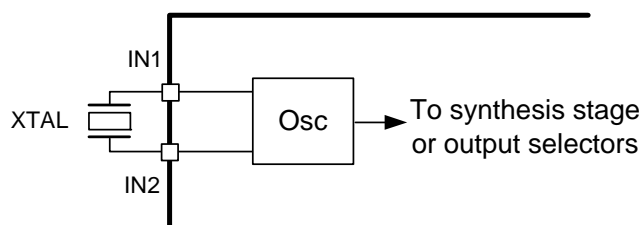

Figure 4. Connecting an XTAL to the Si5338

Refer to “AN360: Crystal Selection Guide for Si533x/5x Devices” for recommended XTAL components.

3.3. Synthesis Stages

Synthesis of the output clocks is performed in two stages as shown in Figure 5. The first stage is a high-frequency analog phase-locked loop (PLL) that multiplies the input stage clock to a frequency within the range of 2.2 to 2.8 GHz. Multiplication of the input frequency is accomplished using a proprietary and highly precise MultiSynth feedback divider (N), which allows the PLL to generate any frequency within its VCO range with less jitter than typical fractional N dividers.

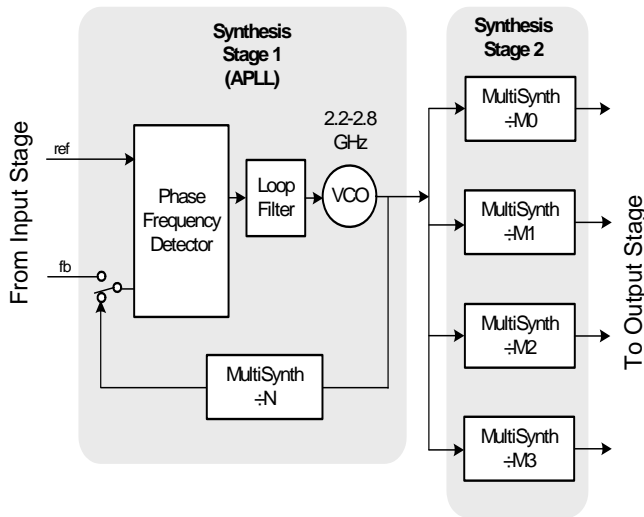

Figure 5. Synthesis Stages

The second stage of synthesis consists of four additional highly-precise MultiSynth output dividers (M0, M1, M2, and M3), which ultimately determine the output clock frequencies. Using this two-stage technique, the Si5338 can generate four independent output clocks with any frequency between the range of 5 to 350 MHz and select ranges up to 710 MHz with 0 ppm accuracy.

3.4. Output Stage

The output stage consists of output selectors, output dividers, and programmable output drivers as shown in Figure 6.

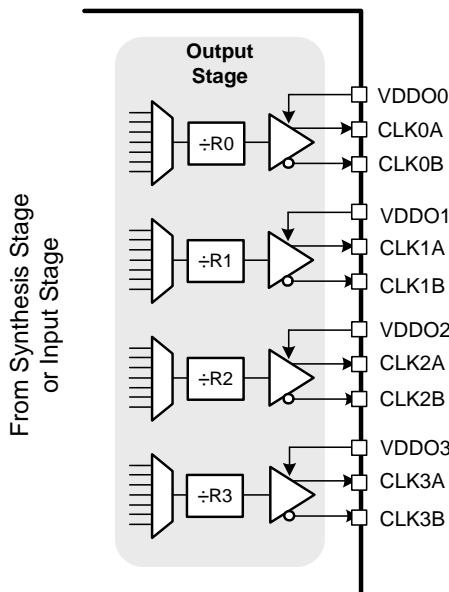

Figure 6. Output Stage

The output selectors select the clock source for the output drivers. By default, each output driver is connected to its own MultiSynth block (e.g. M0 to CLK0, M1 to CLK1, etc), but other combinations are possible by reconfiguring the device. Any of the output drivers can also connect to any of the clocks in the input stage (osc, ref, rediv, fb, or fbdiv) effectively bypassing the synthesis stages. Each of the output drivers can also connect to the first MultiSynth block (M0) enabling a fan-out function. This allows the Si5338 to act as a clock generator, a fanout buffer, or a combination of both in the same package.

The output dividers (R0, R1, R2, R3) allow another stage of clock division. These dividers are configurable as divide by 1 (default), 2, 4, 8, 16, or 32.

The output drivers are configurable to support common signal formats, such as LVPECL, LVDS, HCSL, CMOS, HSTL, and SSTL. Separate output supply pins (VDDOn) are available for generating 3.3, 2.5, 1.8, and 1.5 V signal levels. Additionally, the outputs can be configured to stop high, low, or tri-state when the PLL has lost lock. Each of the outputs can also be enabled or disabled through the I²C port.

3.5. Configuring the Si5338

The Si5338 is a highly-flexible clock generator that is entirely configurable through its I²C interface. The device's default configuration is stored in non-volatile memory (NVM) as shown in Figure 7. The NVM is a one-time programmable memory (OTP), which can store a custom user configuration at power-up. This is a useful feature for applications that need a clock present at power-up (e.g., for providing a clock to a processor).

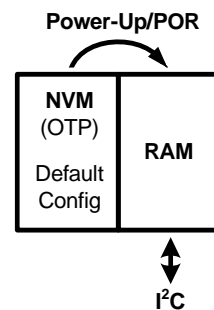

Figure 7. Si5338 Memory Configuration

During a power cycle or a power-on reset (POR), the contents of the NVM are copied into random access memory (RAM), which sets the device configuration that will be used during operation. Any changes to the device configuration after power-up are made by reading and writing to registers in the RAM space through the I²C interface.

Si5338 devices can be factory ordered with a custom configuration stored in NVM, or they can be ordered with a “blank” NVM configuration and configured by writing to RAM using the I²C interface. A blank Si5338 device is one that is shipped with no configuration stored in NVM. A field programmer is also available, which allows writing a custom NVM configuration to a “blank” Si5338. The following sections describe these options.

3.5.1. Ordering a Custom NVM Configuration

The Si5338 is orderable with a factory-programmed custom NVM configuration. This is the simplest way of using the Si5338 since it generates the desired output frequencies at power-up or after a power-on reset (POR). This default configuration is always re-configurable in RAM through the I²C interface after power-up.

The first step in ordering a custom device is generating an NVM file which defines the input and output clock frequencies and signal formats. This is easily done using the *Any Rate Clock Generator* software available from the Silicon Labs website (www.silabs.com/timing). This GUI based software generates an NVM file, which is used by the factory to manufacture custom parts. Each custom part is marked with a unique part number identifying the specific configuration (e.g., Si5338C-A00100-GM). Consult your local sales representative for more details on ordering a custom Si5338.

3.5.2. Writing a Custom Configuration to NVM

An alternative to ordering an Si5338 with a custom NVM configuration is to use the field programming kit (Si5338-PROG-EVB) to write directly to the NVM of a “blank” Si5338. Since NVM is an OTP memory, it can only be written once. The default configuration is always reconfiguring by writing to RAM through the I²C interface.

3.5.3. Writing a Custom Configuration to RAM

The Si5338 device with a “blank” NVM can be configured by writing directly to registers in RAM through the I²C interface. The register map of the Si5338 is addressable as two memory pages each containing 256 8-bit registers as shown in Figure 8.

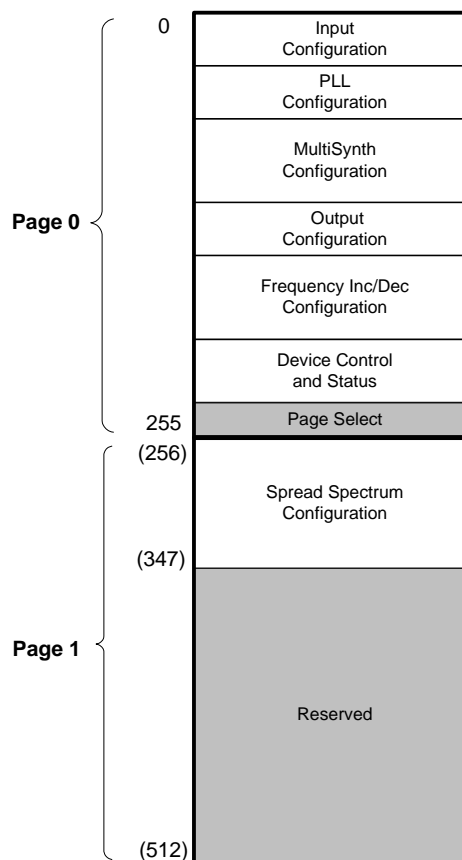

Figure 8. Si5338 Memory Map (RAM)

A full Si5338 software register map is available from the Silicon Labs website (www.silabs.com/timing). For more information on configuring the Si5338 registers, please refer to application note AN411.

Once RAM is configured, a soft reset must be manually initiated (246[1] = 1) to initialize the device to its new frequency configuration. A configuration stored in RAM will have to be re-written after a power cycle or a power-on reset (POR).

3.5.4. Initializing a “Blank” Si5338

Once a “blank” Si5338 has been configured and completes its initial soft reset, the device starts a frequency calibration process (FCAL). A valid clock must be present at the input for FCAL to complete successfully. The FCAL process uses the input clock frequency to center the VCO for optimum lock and hold-in range. Once successful, an 18-bit FCAL value is temporarily stored in RAM (registers 235 to 237) and must be moved to a permanent register location (registers 45 to 47). Once the FCAL value is moved, the FCAL process can be disabled by setting register 49[7] to 1.

If a valid clock is not present during the initial FCAL process, the PLL will declare a loss of lock (LOL) condition and prevent FCAL from running again. The FCAL process will have to be started manually when a valid clock is available at the input. To manually run FCAL, the LOL bit must be disabled (247[7] = 1) followed by another manual soft reset (246[1] = 1).

Note that this initialization procedure is not necessary for devices with custom NVM configurations as described in “3.5.1. Ordering a Custom NVM Configuration” or with “blank” Si5338 devices configured with the external XTAL option for generating free-running clocks.

3.5.5. Changing Output Frequencies “On-The-Fly”

The output MultiSynths (M0–M3) are reconfigurable without requiring a soft reset. This allows frequency reconfiguration of individual output clocks “on-the-fly” without disturbing the other output clocks. A soft reset is required for applications that require initial phase alignment across all outputs clocks.

3.6. Status Indicators

An interrupt pin (INTR) is available to indicate a loss of signal (LOS) condition, a PLL loss of lock (LOL) condition, or that the PLL is in process of acquiring lock (SYS_CAL). As shown in Figure 9, a status register at address 218 is available to help identify the exact event that caused the interrupt pin to become active.

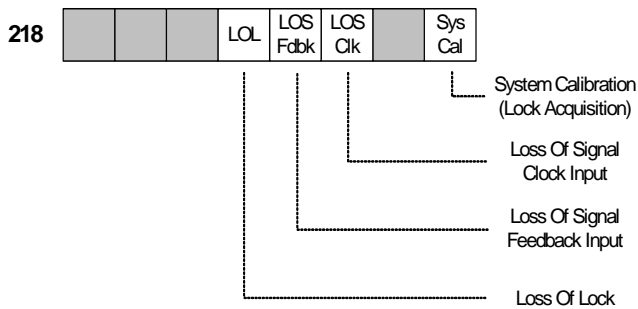

Figure 9. Status Register

The INTR pin provides a useful status indicator for systems that have access to the I²C interface and for systems that do not. Figure 10 shows a typical connection with the required pull-up resistor to VDD.

3.6.1. Using the INTR Pin in Systems with I²C

For systems that use the I²C interface for system monitoring, the INTR pin provides a convenient fault indicator for a processor. Once the interrupt pin becomes active, the processor can identify its trigger by reading the status register. Each of the status bits can be individually masked to prevent them from causing an interrupt.

3.6.2. Using the INTR Pin in Systems without I²C

The INTR pin also provides a useful function in systems that require a pin-controlled fault indicator. Pre-setting the interrupt mask register allows the INTR pin to become an indicator for a specific event, such as LOS and/or LOL. Therefore, the INTR pin can be used to indicate a single fault event or even multiple events.

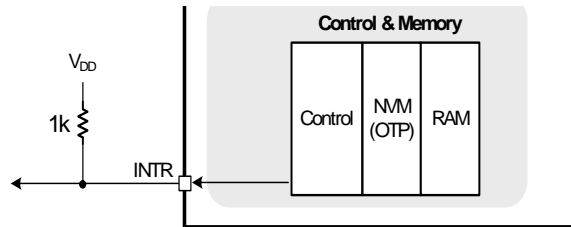

Figure 10. INTR Pin with Required Pull-Up

3.7. Output Enable

There two methods of enabling and disabling the output drivers: Pin control, and I²C control.

3.7.1. Enabling Outputs Using Pin Control

The Si5338K/L/M devices provide an Output Enable pin (OEB) as shown in Figure 11. Pulling this pin high will tri-state all four output drivers.

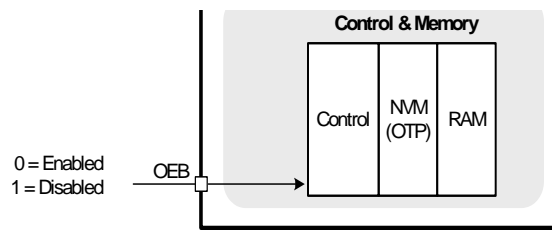

Figure 11. Output Enable Pin (Si5338K/L/M)

3.7.2. Enabling Outputs through the I²C Interface

Output enable can be controlled through the I²C interface. As shown in Figure 12, register 230[3:0] allows control of each individual output driver. Register 230[4] controls all drivers at once. Registers 110[7:6], 114[7:6], 118[7:6], and 112[7:6] control the output disabled state as tri-state, low, high, or always on.

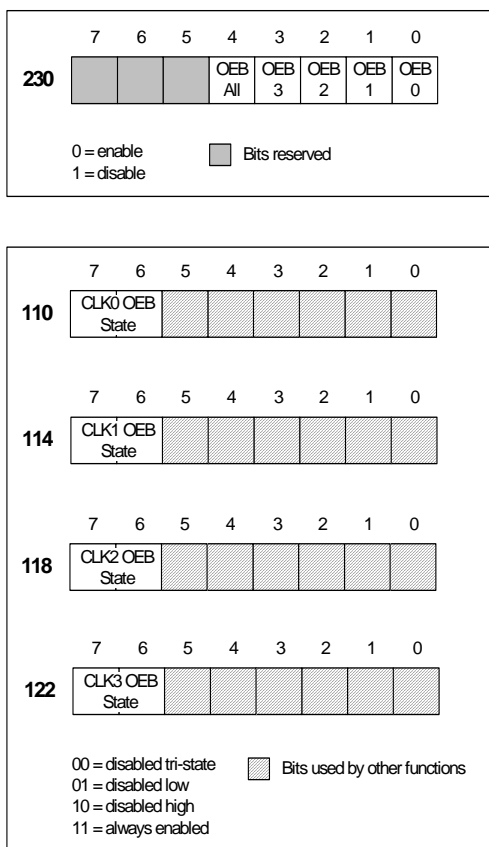

Figure 12. Output Enable Control Registers

3.8. Features of the Si5338

The Si5338 offers several features and functions that are useful in many timing applications. The following paragraphs describe in detail the main features and typical applications.

3.8.1. Frequency Increment/Decrement

Each of the output clock frequencies can be independently stepped up or down in predefined steps as low as 1 ppm per step. Setting of the step size and control of the frequency increment or decrement is accomplished through the I²C interface. Alternatively, the Si5338 can be ordered with optional frequency increment (FINC) and frequency decrement (FDEC) pins for pin-controlled applications. See Table 16 for ordering information of pin-controlled devices.

The frequency increment and decrement feature is useful in applications requiring a variable clock frequency (e.g., CPU speed control, FIFO overflow management, etc.) or in applications where frequency margining (e.g., $f_{out} \pm 5\%$) is necessary for design verification and manufacturing test. Frequency steps are seamless and glitchless.

3.8.2. Output Phase Increment/Decrement

The Si5338 has a digitally-controlled glitchless phase increment and decrement feature that allows adjusting the phase of each output clock in relation to the other output clocks. The phase of each output clock can be adjusted with an accuracy of 20 ps over a range of ± 45 ns. Setting of the step size and control of the phase increment or decrement is accomplished through the I²C interface. Alternatively, the Si5338 can be ordered with optional phase increment (PINC) and frequency decrement (PDEC) pins for pin-controlled applications. See Table 16 for ordering information of pin-controlled devices.

The phase increment and decrement feature provides a useful method for fine tuning setup and hold timing margins or adjusting for mismatched PCB trace lengths.

3.8.3. Zero-Delay Buffer/Clock Generator Mode

The Si5338 supports an optional zero delay mode of operation for applications that require minimal input-to-output delay. In this mode, one of the device output clocks is fed back to the feedback input pin (IN4 or IN5/IN6) to implement an external feedback path essentially nullifying the delay between the reference input and the output clocks. Figure 13 shows the Si5338 in a typical zero-delay buffer configuration. The zero-delay mode combined with the phase increment/decrement feature allows unprecedented flexibility in generating clocks with precise edge alignment.

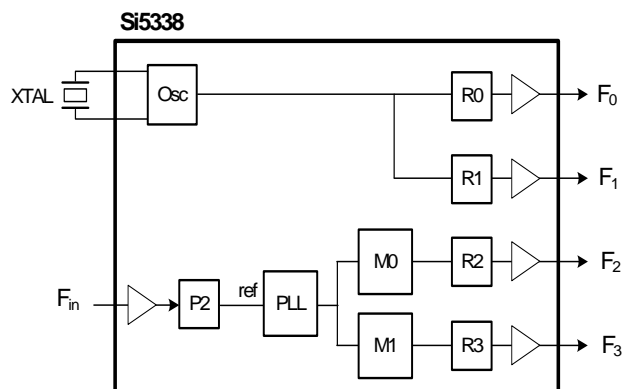

Figure 13. Si5338 as a Zero-Delay Buffer/Clock Generator

3.8.4. Spread Spectrum

To help reduce electromagnetic interference (EMI), the Si5338 supports spread spectrum modulation. The output clock frequencies can be modulated to spread energy across a broader range of frequencies, lowering system EMI. The Si5338 implements spread spectrum using its patented MultiSynth technology to achieve previously unattainable precision in both modulation

rate and spreading magnitude as shown in Figure 14. Spread spectrum can be applied to any output clock, any clock frequency, and any spread amount. The device supports center spread ($\pm 0.1\%$ to $\pm 5\%$) and down spread (-0.1% to -5%). In addition, the device has extensive on-chip voltage regulation so that power supply variations do not influence the device's spread-spectrum clock waveforms.

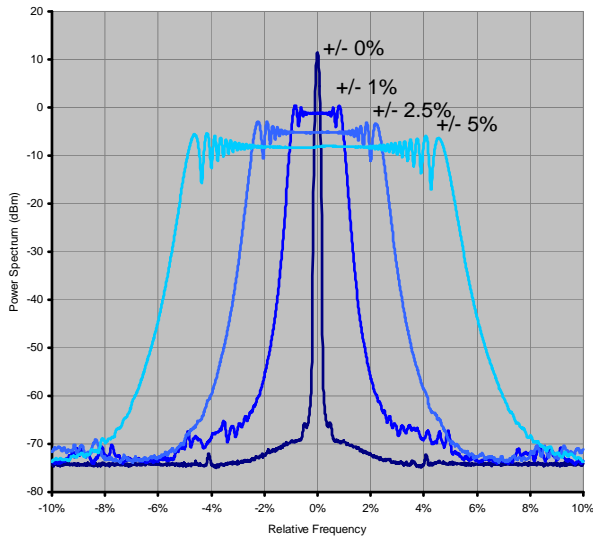

Figure 14. Configurable Spread Spectrum

4. Applications of the Si5338

Because of its flexible architecture, the Si5338 can be configured to serve several functions in the timing path. The following sections describe some common applications.

4.1. Free-Running Clock Generator

Using the internal oscillator (Osc) and an inexpensive external crystal (XTAL), the Si5338 can be configured as a free-running clock generator for replacing high-end and long-lead-time crystal oscillators found on many printed circuit boards (PCBs). Replacing several crystal oscillators with a single IC solution helps consolidate the bill of materials (BOM), reduces the number of suppliers, and reduces the number of long-lead-time components on the PCB. In addition, since crystal oscillators tend to be the least reliable aspect of many systems, the overall FIT rate improves with the elimination of each oscillator.

Up to four independent clock frequencies can be generated at any rate within its supported frequency range and with any of supported output types. Features, such as frequency increment and decrement and phase adjustments on a per-output basis, provide unprecedented flexibility for PCB designs. Figure 15 shows the Si5338 configured as a free-running clock generator.

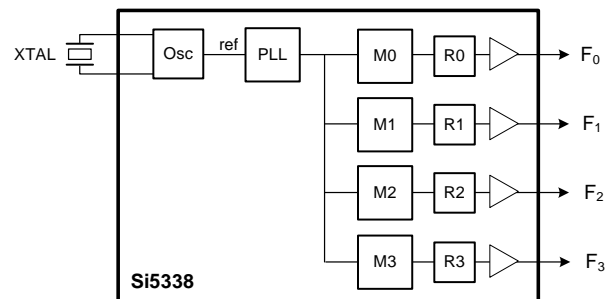

Figure 15. Si5338 as a Free-Running Clock Generator

4.2. Synchronous Frequency Translation

In other cases, it is useful to generate an output frequency that is synchronous (or phase-locked) to another clock frequency. The Si5338 is the ideal choice for generating up to four clocks with different frequencies with a fixed phase relationship to an input reference. Because of its highly precise frequency synthesis, the Si5338 can generate all four output frequencies with 0 ppm error to the input reference. The Si5338 is an ideal choice for applications that have traditionally required multiple stages of frequency

synthesis to achieve complex frequency translations. Examples are in broadcast video (e.g., 148.5 MHz to 148.351648351648 MHz), WAN/LAN applications (e.g. 155.52 MHz to 156.25 MHz), and Forward Error Correction (FEC) applications (e.g., 156.25 MHz to 161.1328125 MHz). Using the input reference selectors, the Si5338 can select from one of four inputs (IN1/IN2, IN3, IN4, and IN5/IN6). Figure 16 shows the Si5338 configured as a synchronous clock generator.

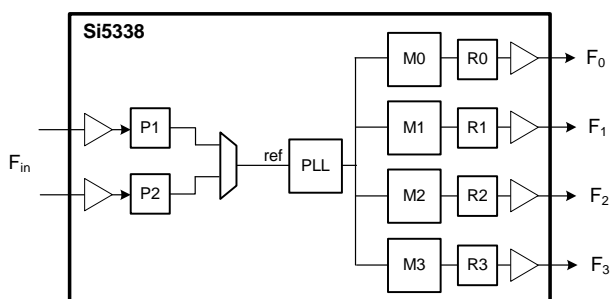

Figure 16. Si5338 as a Synchronous Clock Generator or Frequency Translator

4.3. Configurable Buffer and Level Translator

Using the output selectors, the synthesis stage can be entirely bypassed allowing the Si5338 to act as a configurable clock buffer/divider with level translation and selectable inputs. Because of its highly selectable configuration, virtually any combination is possible. The configurable output drivers allow four differential outputs, eight single-ended outputs, or a combination of both. Figure 17 shows the Si5338 configured as a flexible clock buffer.

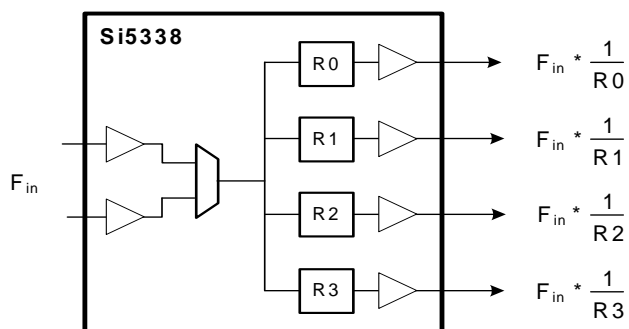

Figure 17. Si5338 as a Configurable Clock Buffer/Divider with Level Translation

4.3.1. Combination Free-Running and Synchronous Clock Generator

Another application of the Si5338 is in generating both free-running and synchronous clocks in one device. This is accomplished by configuring the input and output selectors for the desired split configuration. An example of such an application is shown in Figure 18.

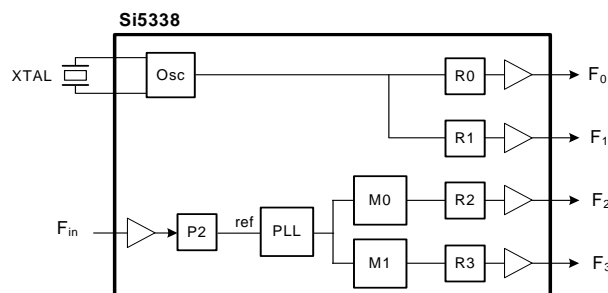

Figure 18. Si5338 In a Free-Running and Synchronous Clock Generator Application

5. I²C Interface

Configuration and operation of the Si5338 is controlled by reading and writing to the RAM space using the I²C interface. The device operates in slave mode with 7-bit addressing and can operate in Standard-Mode (100 kbps) or Fast-Mode (400 kbps) and supports burst data transfer with auto address increments.

The I²C bus consists of a bidirectional serial data line (SDA) and a serial clock input (SCL) as shown in Figure 19. Both the SDA and SCL pins must be connected to the VDD supply via an external pull-up as recommended by the I²C specification.

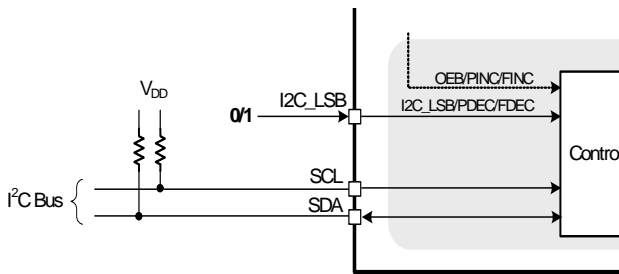

Figure 19. I²C and Control Signals

The 7-bit device (slave) address of the Si5338 consists of a 6-bit fixed address plus a user-selectable LSB bit as shown in Figure 20. The LSB bit is selectable using the optional I2C_LSB pin which is available as an ordering option for applications that require more than one Si5338 on a single I²C bus. Devices without the I2C_LSB pin option have a fixed 7-bit address of 70h as shown in Figure 20. Other custom I²C addresses are also possible. See Table 16 for details on device ordering information with the optional I2C_LSB pin.

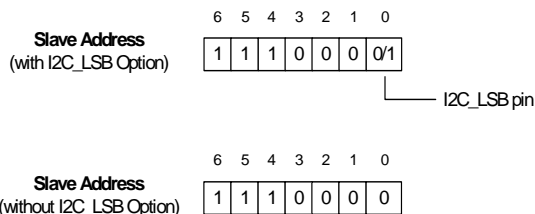

Figure 20. Si5338 I²C Slave Address

Data is transferred MSB first in 8-bit words as specified by the I²C specification. A write command consists of a 7-bit device (slave) address + a write bit, an 8-bit register address, and 8 bits of data as shown in Figure 21. A write burst operation is also shown where every additional data word is written using an auto-incremented address.

Write Operation – Single Byte



Write Operation - Burst (Auto Address Increment)

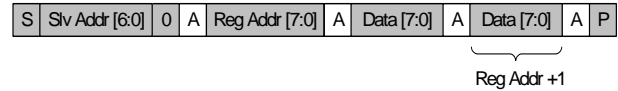

- From slave to master
- From master to slave
- 1 – Read
- 0 – Write
- A – Acknowledge (SDA LOW)
- N – Not Acknowledge (SDA HIGH)
- S – START condition
- P – STOP condition

Figure 21. I²C Write Operation

A read operation is performed in two stages. A data write is used to set the register address, then a data read is performed to retrieve the data from the set address. A read burst operation is also supported. This is shown in Figure 22.

Read Operation – Single Byte

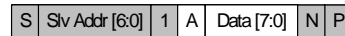

Read Operation - Burst (Auto Address Increment)

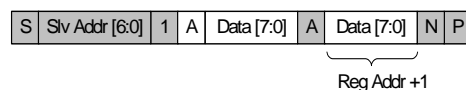

- From slave to master
- From master to slave
- 1 – Read
- 0 – Write
- A – Acknowledge (SDA LOW)
- N – Not Acknowledge (SDA HIGH)
- S – START condition
- P – STOP condition

Figure 22. I²C Read Operation

AC and dc electrical specifications for the SCL and SDA pins are shown in Table 14. The timing specifications and timing diagram for the I²C bus is compatible with the I²C-Bus Standard. SDA timeout is supported for compatibility with SMBus interfaces.

The I²C bus can be operated at a bus voltage of 1.71 to 3.63 V and is 3.3 V tolerant.

6. Pin Descriptions

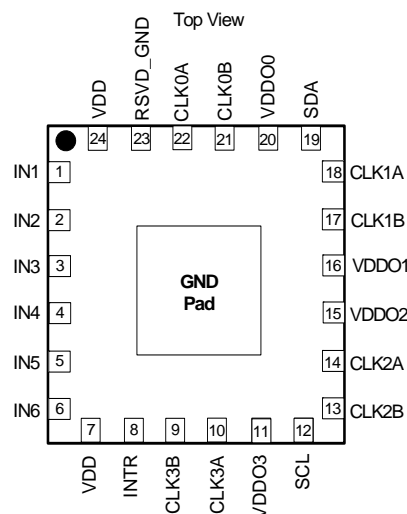

Note: Center pad must be tied to GND for normal operation.

Table 15. Si5338 Pin Descriptions

Pin #	Pin Name	I/O	Signal Type	Description
1,2	IN1/IN2	I	Multi	<p>CLKIN/CLKINB.</p> <p>These pins are used as the main differential clock input or as the XTAL input. See "3.2. Input Stage" on page 17, Figure 3 and Figure 4, for connection details.</p> <p>When not in use, leave IN1 unconnected and IN2 connected to GND.</p>
3	IN3	I	Multi	<p>This pin can have one of the following functions depending on the part number:</p> <p>CLKIN (for Si5338A/B/C and Si5338N/P/Q devices only)</p> <p>Provides a high-impedance clock input for single ended clock signals, such as CMOS, SSTL, or HSTL. This input should be dc-coupled as shown in "3.2. Input Stage", Figure 3.</p> <p>If this pin is not used, it should be connected to ground.</p> <p>PINC (for Si5338D/E/F devices only)</p> <p>Used as the phase increment pin. See "3.8.2. Output Phase Increment/Decrement" on page 21 for more details. Minimum pulse width of 100 ns is required for proper operation. If this pin is not used, it should be connected to ground.</p> <p>FINC (for Si5338G/H/J devices only)</p> <p>Used as the frequency increment pin. See "3.8.1. Frequency Increment/Decrement" on page 21 for more details. Minimum pulse width of 100 ns is required for proper operation. If this pin is not used, it should be connected to ground.</p> <p>OEB (for Si5338K/L/M devices only)</p> <p>Used as an output enable pin. 0 = All outputs enabled; 1 = All outputs disabled. By default, outputs are tri-stated when disabled.</p>

Table 15. Si5338 Pin Descriptions (Continued)

Pin #	Pin Name	I/O	Signal Type	Description
4	IN4	I	Multi	<p>This pin can have one of the following functions depending on the part number</p> <p>I2C_LSB (for Si5338A/B/C and Si5338K/L/M devices only) This is the LSB of the Si5338 I²C address. 0 = I²C address 70h, 1 = I²C address 71h.</p> <p>FDBK (for Si5338N/P/Q devices only) Provides a high-impedance feedback input for single-ended clock signals, such as CMOS, SSTL, or HSTL. This input should be dc-coupled as shown in "3.2. Input Stage", Figure 3. If this pin is not used, it should be connected to ground.</p> <p>PDEC (for Si5338D/E/F) devices only) Used as the phase decrement pin. See "3.8.2. Output Phase Increment/Decrement" for more details. Minimum pulse width of 100 ns is required for proper operation. If this pin is not used, it should be connected to ground.</p> <p>FDEC (for Si5338G/H/J devices only) Used as the frequency decrement pin. See "3.8.1. Frequency Increment/Decrement" for more details. Minimum pulse width of 100 ns is required for proper operation. If this pin is not used, it should be connected to ground.</p>
5,6	IN5/IN6	I	Multi	<p>FDBK/FDBKB. These pins can be used as a differential feedback input in zero delay buffer mode or as a secondary clock input. See section 3.2, Figure 3, for termination details. See "3.8.3. Zero-Delay Buffer/Clock Generator Mode" on page 21 for zero delay buffer mode set-up. When not in use, leave IN5 unconnected and IN6 connected to GND.</p>
7	VDD	VDD	Supply	<p>Core Supply Voltage. This is the core supply voltage, which can operate from a 1.8, 2.5, or 3.3 V supply. A 0.1 μF bypass capacitor should be located very close to this pin.</p>
8	INTR	O	Open Drain	<p>Interrupt. This pin functions as a maskable interrupt output. 0 = No interrupt. 1 = Interrupt present. This pin requires a pull-up resistor of at least 1 kΩ.</p>
9	CLK3B	O	Multi	<p>Output Clock B for Channel 3. May be a single-ended output or half of a differential output with CLK3A being the other differential half.</p>
10	CLK3A	O	Multi	<p>Output Clock A for Channel 3. May be a single-ended output or half of a differential output with CLK3B being the other differential half.</p>
11	VDDO3	VDD	Supply	<p>Output Clock Supply Voltage. Supply voltage (3.3, 2.5, 1.8, or 1.5 V) for CLK3A,B. A 0.1 μF capacitor must be located very close to this pin. If CLK3 is not used, this pin must be tied to VDD (pin 7, 24).</p>

Table 15. Si5338 Pin Descriptions (Continued)

Pin #	Pin Name	I/O	Signal Type	Description
12	SCL	I	LVC MOS	I²C Serial Clock Input. This is the serial clock input for the I ² C bus. This pin must be pulled-up using a pull-up resistor of at least 1 kΩ.
13	CLK2B	O	Multi	Output Clock B for Channel 2. May be a single-ended output or half of a differential output with CLK2A being the other differential half.
14	CLK2A	O	Multi	Output Clock A for Channel 2. May be a single-ended output or half of a differential output with CLK2B being the other differential half.
15	VDDO2	VDD	Supply	Output Clock Supply Voltage. Supply voltage (3.3, 2.5, 1.8, or 1.5 V) for CLK2A,B. A 0.1 μ F capacitor must be located very close to this pin. If CLK2 is not used, this pin must be tied to VDD (pin 7, 24).
16	VDDO1	VDD	Supply	Output Clock Supply Voltage. Supply voltage (3.3, 2.5, 1.8, or 1.5 V) for CLK1A,B. A 0.1 μ F capacitor must be located very close to this pin. If CLK1 is not used, this pin must be tied to VDD (pin 7, 24).
17	CLK1B	O	Multi	Output Clock B for Channel 1. May be a single-ended output or half of a differential output with CLK1A being the other differential half.
18	CLK1A	O	Multi	Output Clock A for Channel 1. May be a single-ended output or half of a differential output with CLK1B being the other differential half.
19	SDA	I/O	LVC MOS	I²C Serial Data. This is the serial data for the I ² C bus. This pin must be pulled-up using a pull-up resistor of at least 1 kΩ.
20	VDDO0	VDD	Supply	Output Clock Supply Voltage. Supply voltage (3.3, 2.5, 1.8, or 1.5 V) for CLK0A,B. A 0.1 μ F capacitor must be located very close to this pin. If CLK0 is not used, this pin must be tied to VDD (pin 7, 24).
21	CLK0B	O	Multi	Output Clock B for Channel 0. May be a single-ended output or half of a differential output with CLK0A being the other differential half.
22	CLK0A	O	Multi	Output Clock A for Channel 0. May be a single-ended output or half of a differential output with CLK0B being the other differential half.
23	GND	GND	GND	Ground. Must be connected to system ground. Minimize the ground path impedance for optimal performance of this device.

Table 15. Si5338 Pin Descriptions (Continued)

Pin #	Pin Name	I/O	Signal Type	Description
24	VDD	VDD	Supply	Core Supply Voltage. The device operates from a 1.8, 2.5, or 3.3 V supply. A 0.1 μ F bypass capacitor should be located very close to this pin.
GND PAD	GND	GND	GND	Ground Pad. This is the large pad in the center of the package. Use as many vias as possible to connect this pad to a ground plane. Device specifications cannot be guaranteed unless the ground pad is properly connected to a ground plane on the PCB.

7. Device Pinout by Part Number

The Si5338 is orderable in three different speed grades: Si5338A/D/G/K/N have a maximum output clock frequency limit of 710 MHz. Si5338B/E/H/L/P have a maximum output clock frequency of 350 MHz. Si5338C/F/J/M/Q have a maximum output clock frequency of 200 MHz.

Devices are also orderable according to the pin control functions available on Pins 3 and 4:

- **CLKIN**—single-ended clock input
- **I2C_LSB**—determines the LSB bit of the 7-bit I²C address
- **FINC**—frequency increment pin
- **FDEC**—frequency decrement pin
- **PINC**—phase increment pin
- **PDEC**—phase decrement pin
- **FDBK**—single-ended feedback input
- **OEB**—output enable

Table 16. Pin Function by Part Number

Pin #	Si5338A: 710 MHz Si5338B: 350 MHz Si5338C: 200 MHz	Si5338D: 710 MHz Si5338E: 350 MHz Si5338F: 200 MHz	Si5338G: 710 MHz Si5338H: 350 MHz Si5338J: 200 MHz	Si5338K: 710 MHz Si5338L: 350 MHz Si5338M: 200 MHz	Si5338N: 710 MHz Si5338P: 350 MHz Si5338Q: 200 MHz
1	CLKIN ¹	CLKIN ¹	CLKIN ¹	CLKIN ¹	CLKIN ¹
2	CLKINB ¹	CLKINB ¹	CLKINB ¹	CLKINB ¹	CLKINB ¹
3	CLKIN ²	PINC	FINC	OEB	CLKIN ²
4	I2C_LSB	PDEC	FDEC	I2C_LSB	FDBK ³
5	FDBK ⁴	FDBK ⁴	FDBK ⁴	FDBK ⁴	FDBK ⁴
6	FDBKB ⁴	FDBKB ⁴	FDBKB ⁴	FDBKB ⁴	FDBKB ⁴
7	VDD	VDD	VDD	VDD	VDD
8	INTR	INTR	INTR	INTR	INTR
9	CLK3B	CLK3B	CLK3B	CLK3B	CLK3B
10	CLK3A	CLK3A	CLK3A	CLK3A	CLK3A
11	VDDO3	VDDO3	VDDO3	VDDO3	VDDO3
12	SCL	SCL	SCL	SCL	SCL
13	CLK2B	CLK2B	CLK2B	CLK2B	CLK2B
14	CLK2A	CLK2A	CLK2A	CLK2A	CLK2A
15	VDDO2	VDDO2	VDDO2	VDDO2	VDDO2
16	VDDO1	VDDO1	VDDO1	VDDO1	VDDO1
17	CLK1B	CLK1B	CLK1B	CLK1B	CLK1B
18	CLK1A	CLK1A	CLK1A	CLK1A	CLK1A
19	SDA	SDA	SDA	SDA	SDA

Notes:

1. CLKIN/CLKINB on pins 1 and 2 are differential clock inputs or XTAL inputs.
2. CLKIN on pin 3 is a single-ended clock input.
3. FDBK on pin 4 is a single-ended feedback input.
4. FDBK/FDBKB on pins 5 and 6 are differential feedback inputs.

Table 16. Pin Function by Part Number (Continued)

Pin #	Si5338A: 710 MHz Si5338B: 350 MHz Si5338C: 200 MHz	Si5338D: 710 MHz Si5338E: 350 MHz Si5338F: 200 MHz	Si5338G: 710 MHz Si5338H: 350 MHz Si5338J: 200 MHz	Si5338K: 710 MHz Si5338L: 350 MHz Si5338M: 200 MHz	Si5338N: 710 MHz Si5338P: 350 MHz Si5338Q: 200 MHz
20	VDDO0	VDDO0	VDDO0	VDDO0	VDDO0
21	CLK0B	CLK0B	CLK0B	CLK0B	CLK0B
22	CLK0A	CLK0A	CLK0A	CLK0A	CLK0A
23	GND	GND	GND	GND	GND
24	VDD	VDD	VDD	VDD	VDD

Notes:

1. CLKIN/CLKINB on pins 1 and 2 are differential clock inputs or XTAL inputs.
2. CLKIN on pin 3 is a single-ended clock input.
3. FDBK on pin 4 is a single-ended feedback input.
4. FDBK/FDBKB on pins 5 and 6 are differential feedback inputs.

8. Package Outline: 24-Lead QFN

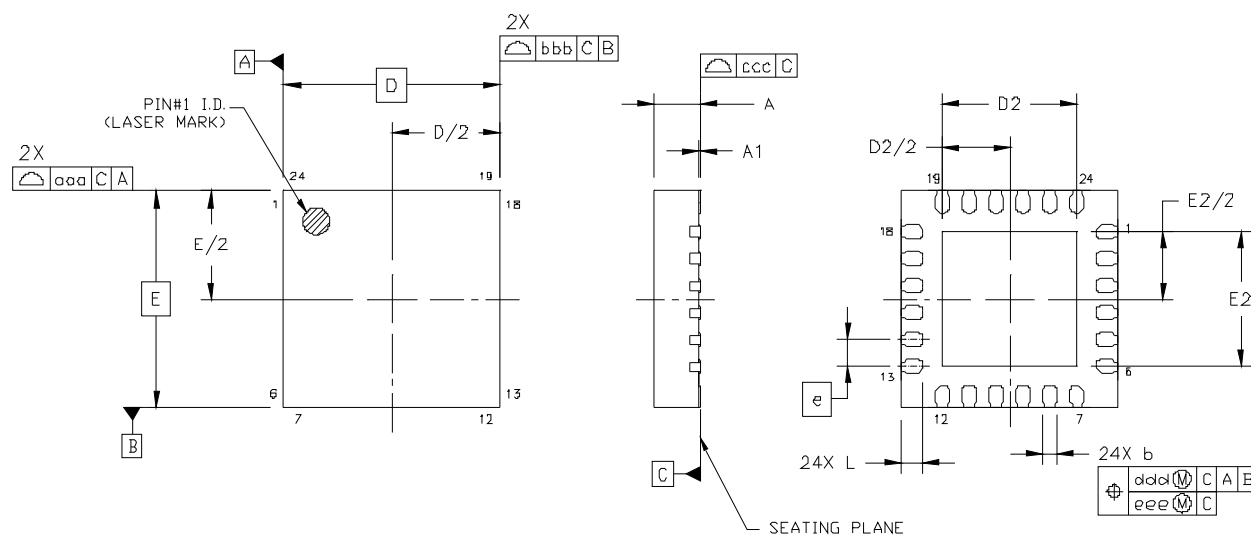

Figure 23. 24-Lead Quad Flat No-lead (QFN)

Table 17. Package Dimensions

Dimension	Min	Nom	Max
A	0.80	0.85	0.90
A1	0.00	0.02	0.05
b	0.18	0.25	0.30
D	4.00 BSC.		
D2	2.35	2.50	2.65
e	0.50 BSC.		
E	4.00 BSC.		
E2	2.35	2.50	2.65
L	0.30	0.40	0.50
aaa	0.10		
bbb	0.10		
ccc	0.08		
ddd	0.10		
eee	0.05		

Notes:

1. All dimensions shown are in millimeters (mm) unless otherwise noted.
2. Dimensioning and Tolerancing per ANSI Y14.5M-1994.
3. This drawing conforms to the JEDEC Outline MO-220, variation VGGD-8.
4. Recommended card reflow profile is per the JEDEC/IPC J-STD-020C specification for Small Body Components.

9. Recommended PCB Layout

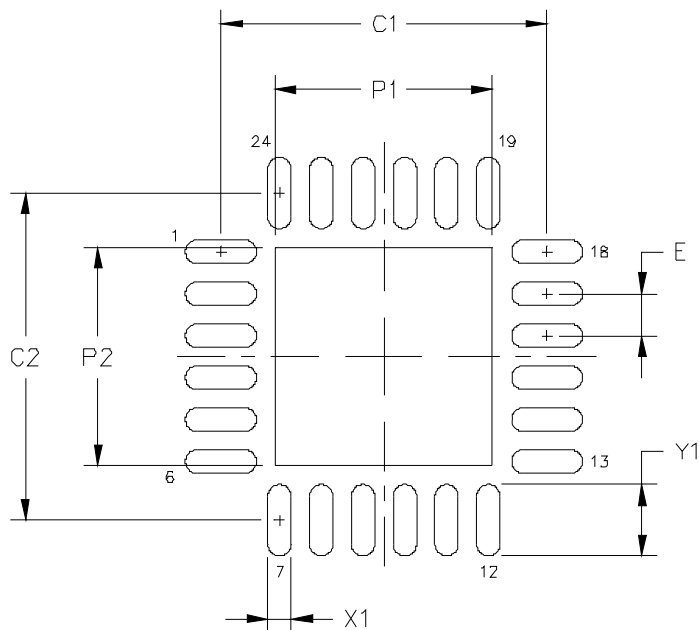

Table 18. PCB Land Pattern

Dimension	Min	Nom	Max
P1	2.50	2.55	2.60
P2	2.50	2.55	2.60
X1	0.20	0.25	0.30
Y1	0.75	0.80	0.85
C1		3.90	
C2		3.90	
E		0.50	

Notes:

General

1. All dimensions shown are in millimeters (mm) unless otherwise noted.
2. Dimensioning and Tolerancing per ANSI Y14.5M-1994 specification.
3. This Land Pattern Design is based on the IPC-7351 guidelines.

Solder Mask Design

4. All metal pads are to be non-solder mask defined (NSMD). Clearance between the solder mask and the metal pad is to be 60 μm minimum, all the way around the pad.

Stencil Design

5. A stainless steel, laser-cut and electro-polished stencil with trapezoidal walls should be used to assure good solder paste release.
6. The stencil thickness should be 0.125 mm (5 mils).
7. The ratio of stencil aperture to land pad size should be 1:1 for all perimeter pins.
8. A 2x2 array of 1.0 mm square openings on 1.25 mm pitch should be used for the center ground pad.

Card Assembly

9. A No-Clean, Type-3 solder paste is recommended.
10. The recommended card reflow profile is per the JEDEC/IPC J-STD-020C specification for Small Body Components.

10. Ordering Information

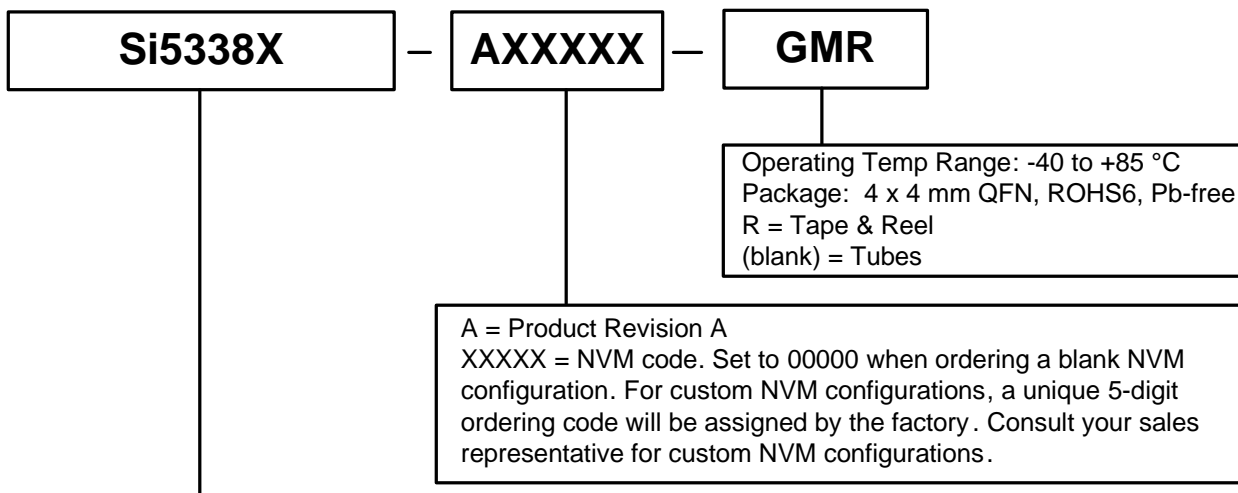

Si5338A	-	0.16 MHz to 700 MHz I2C_LSB
Si5338B	-	0.16 MHz to 350 MHz I2C_LSB
Si5338C	-	0.16 MHz to 200 MHz I2C_LSB
Si5338D	-	0.16 MHz to 700 MHz Phase Inc/Dec Pin Control
Si5338E	-	0.16 MHz to 350 MHz Phase Inc/Dec Pin Control
Si5338F	-	0.16 MHz to 200 MHz Phase Inc/Dec Pin Control
Si5338G	-	0.16 MHz to 700 MHz Freq Inc/Dec Pin Control
Si5338H	-	0.16 MHz to 350 MHz Freq Inc/Dec Pin Control
Si5338J	-	0.16 MHz to 200 MHz Freq Inc/Dec Pin Control
Si5338K	-	0.16 MHz to 700 MHz OEB Pin Control + I2C_LSB
Si5338L	-	0.16 MHz to 350 MHz OEB Pin Control + I2C_LSB
Si5338M	-	0.16 MHz to 200 MHz OEB Pin Control + I2C_LSB
Si5338N	-	0.16 MHz to 700 MHz Four Inputs (2 Differential, 2 Single-ended)
Si5338P	-	0.16 MHz to 350 MHz Four Inputs (2 Differential, 2 Single-ended)
Si5338Q	-	0.16 MHz to 200 MHz Four Inputs (2 Differential, 2 Single-ended)

Evaluation Boards

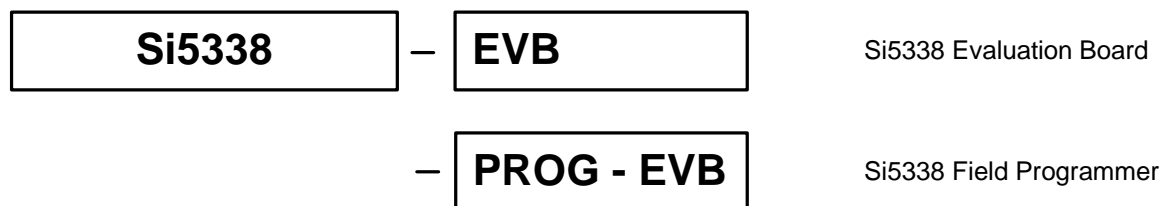

DOCUMENT CHANGE LIST

Revision 0.1 to 0.2

- Updated block diagram to show Rn output divider and PLL bypass mode
- Updated pin description to include FDBK±
- Updated Table 4. DC Characteristics
- Updated Table 12. Jitter Specifications
- Added Supply Current vs. Output Frequency
- Updated package outline specification
- Clarified input clock configuration register settings
- Updated DRV_INVERTn[1:0] settings
- Added PLL bypass mode
- Added LOS_FDBK description
- Added additional detail to phase increment/decrement and frequency increment/decrement descriptions
- Clarified output driver powerdown options
- Clarified entry to self-calibration mode
- Updated ordering guide

Revision 0.2 to 0.3

- Changed minimum output clock frequency from 5 MHz to 1 MHz.
- Updated slew rates.
- Updated "Features" on page 1.
- Updated Table 6, "Input and Output Clock Characteristics," on page 7.
- Deleted Table 12, "Output Driver Slew Rate Control".

Revision 0.3 to 0.5

- Major editorial changes to all sections to improve clarity
- Completed electrical specification tables with final characterization results
- Revised the maximum input and output frequencies from 700 MHz to 710 MHz
- Improved jitter specifications to reflect updated characterization results
- Added new Si5338N/P/Q ordering codes
- Added typical application diagrams
- Added an application section to highlight the flexibility of the Si5338 in various timing functions
- Added a configuration section to clarify configuration options

Revision 0.5 to 0.55

- Editorial changes to section 3.5 "Configuring the Si5338" to improve clarity on ordering custom Si5338 and on configuring "blank" Si5338.
- Added pin numbers to device package drawings.
- Updated ordering information to include evaluation boards.
- Updated first page description and applications
- Added θ_{JC} to specification tables.
- Added GbE RM jitter specification with 1.875–20 MHz integration band.

NOTES:

CONTACT INFORMATION

Silicon Laboratories Inc.

400 West Cesar Chavez
Austin, TX 78701
Tel: 1+(512) 416-8500
Fax: 1+(512) 416-9669
Toll Free: 1+(877) 444-3032

Please visit the Silicon Labs Technical Support web page:
<https://www.silabs.com/support/pages/contacttechnicalsupport.aspx>
and register to submit a technical support request.

The information in this document is believed to be accurate in all respects at the time of publication but is subject to change without notice. Silicon Laboratories assumes no responsibility for errors and omissions, and disclaims responsibility for any consequences resulting from the use of information included herein. Additionally, Silicon Laboratories assumes no responsibility for the functioning of undescribed features or parameters. Silicon Laboratories reserves the right to make changes without further notice. Silicon Laboratories makes no warranty, representation or guarantee regarding the suitability of its products for any particular purpose, nor does Silicon Laboratories assume any liability arising out of the application or use of any product or circuit, and specifically disclaims any and all liability, including without limitation consequential or incidental damages. Silicon Laboratories products are not designed, intended, or authorized for use in applications intended to support or sustain life, or for any other application in which the failure of the Silicon Laboratories product could create a situation where personal injury or death may occur. Should Buyer purchase or use Silicon Laboratories products for any such unintended or unauthorized application, Buyer shall indemnify and hold Silicon Laboratories harmless against all claims and damages.

Silicon Laboratories and Silicon Labs are trademarks of Silicon Laboratories Inc.
Other products or brandnames mentioned herein are trademarks or registered trademarks of their respective holders.