

CRYSTAL SELECTION GUIDE FOR THE Si4x6x/Si4x55 RF ICs

1. Introduction

The aim of this application note is to give a better understanding of crystal and TCXO interfacing to our Si4x6x/Si4x55 ISM band transmitter, receiver and transceiver ICs. The most important parameters when selecting the proper crystal oscillator are the following:

Nominal Frequency: 25...32 MHz (typically 30 MHz; for more details please see section 4)

Equivalent Series Resistance: ESR: max. 80 Ω

Load Capacitance: Cload, C_L : max. 10 pF

Shunt Capacitance: C_0 (as low as possible, typically 3–4 pF)

Frequency Stability over Operating Temperature Range: typically ± 10 ppm (depends on the application)

2. Theoretical Background

The 30 MHz crystal oscillator of the Si4x6x/Si4x55 family uses the crystal in parallel resonance mode. In this mode, the resonator consists of the crystal itself and a “load capacitance.” Figure 1 shows this capacitance (C_L) together with the electrical model of the crystal.

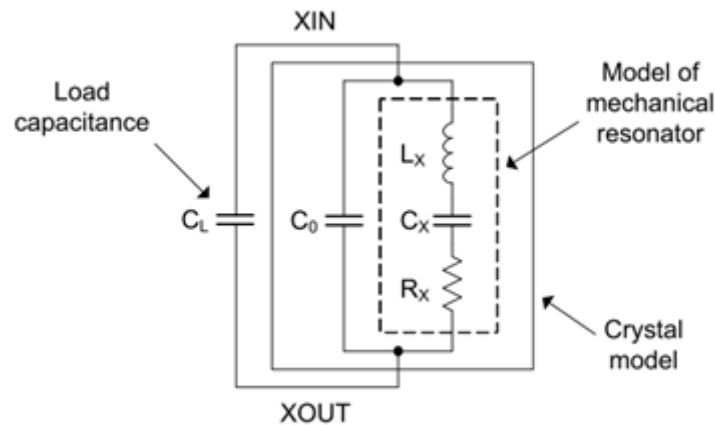

Figure 1. Crystal in Parallel Resonance Mode

The most commonly used names for the components in crystal model are:

L_x	Motional inductance
C_x	Motional capacitance
R_x	Loss resistance
C_0	Pin/holder capacitance

The addition of C_L detunes the mechanical resonator from the series resonance frequency, f_S , determined here by L_x and C_x . $f_P = f_S \times (1 + C_x / (2 \times (C_0 + C_L)))$.

AN785

In order to get an accurate oscillation frequency, f_p , it is important to provide the required amount of load capacitance specified by the crystal manufacturer. Normally, C_X is not given in the data sheets, and there is only a maximum shown for C_0 . Typical standard values of C_L are 8, 10, 12 and 16 pF.

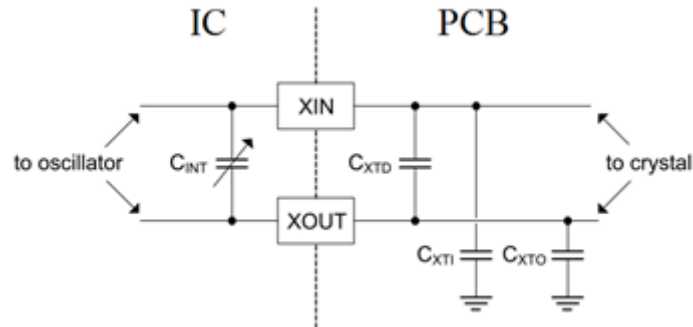

Figure 2. Resonator-Connected Capacitances

3. Si4x6x/Si4x55 Oscillator's Features

The Si4x6x/Si4x55 includes an integrated crystal oscillator with a fast start-up time of less than 250 μ s. The design is differential with the required crystal load capacitance integrated on-chip to minimize the number of external components. By default, all that is required off-chip is the crystal. The default crystal frequency is 30 MHz, but the circuit is designed to handle any XTAL from 25 to 32 MHz. If a crystal with nominal frequency different than 30 MHz is used, the POWER_UP API boot command must be modified. The WDS calculator crystal frequency field must also be changed to reflect the frequency being used.

The crystal load capacitance can be digitally programmed to accommodate crystals with various load capacitance requirements and to adjust the frequency of the crystal oscillator. The tuning of the crystal load capacitance is programmed through the GLOBAL_XO_TUNE API property. The total internal capacitance is 11 pF and is adjustable in 127 steps (70 fF/step).

When tight frequency tolerance is required (e.g., narrow band applications) there are two possible options:

1. Use an external high precision reference (e.g., TCXO, OCXO).
2. Use the crystal frequency adjustment to compensate for crystal production tolerances. The frequency offset characteristics of the capacitor bank are demonstrated in Figure 3. Utilizing the on-chip temperature sensor and suitable control software, the temperature dependency of the crystal can be canceled.

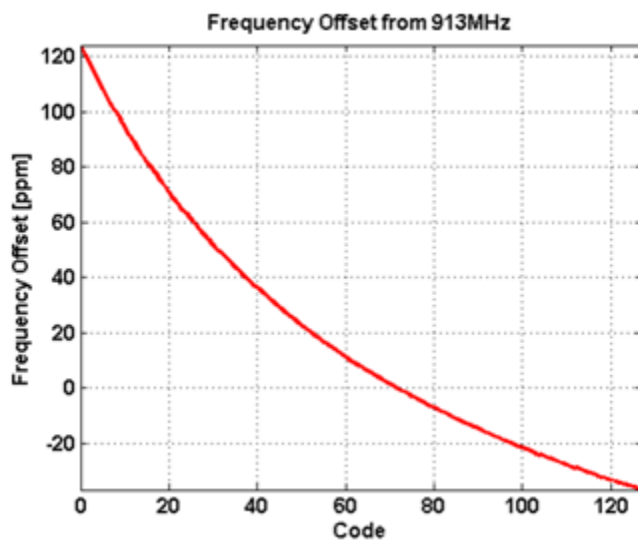

Figure 3. Capacitor Bank Frequency Offset Characteristics

When placing the crystal on the PCB layout and routing the crystal and radio interconnections, the designer must consider minimizing trace length, thus decreasing possible parasitic effects and EMC issues.

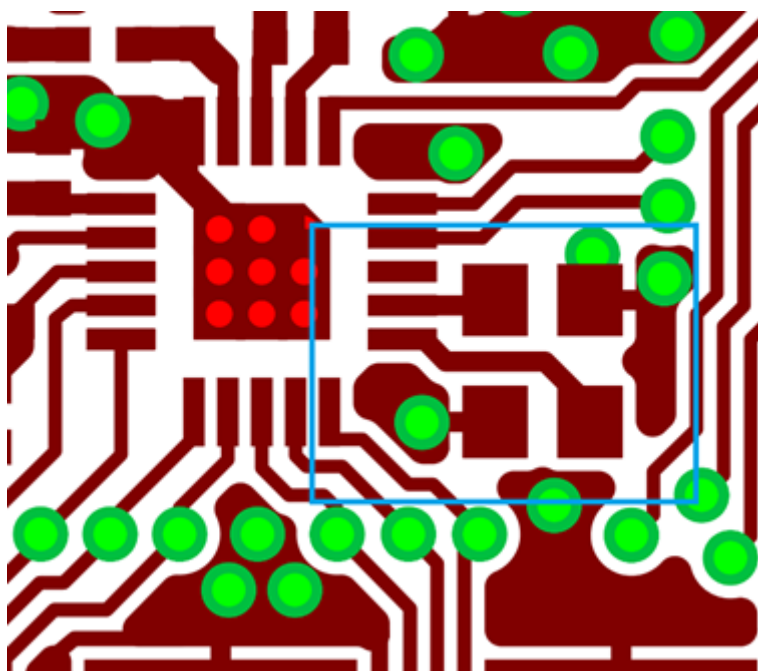

Figure 4. Reference Design Layout Example of a Crystal Connection

4. Frequency Selection

The recommended nominal crystal frequency is 30 MHz for each radio type. One exception is when the product is designed for the **868 MHz band**, where the recommended crystal frequency is **26 MHz**, as used in our reference designs as well. Due to the architecture of the Si4x6x/Si4x55, unwanted spurious emission may be seen at frequencies equal to the difference between the center frequency and the nearest crystal harmonic. Crystal harmonics can also desensitize the receiver and degrade sensitivity. It is suggested to carefully choose the crystal frequency to move its harmonics away from the desired radio frequency. Silicon Labs suggests using 26 MHz in the 868 MHz European band. It should be noted that the maximum achievable data rate scales according to the crystal frequency (433 kbps vs 500 kbps at 26 MHz in 2GFSK). Selecting the right crystal frequency is a trade-off between RF carrier frequency, location of crystal harmonics and maximum achievable data rate.

When selecting the reference crystal for an application, one of the most important factors is the accuracy, which depends on the radio link parameters (data rate, deviation, RX filter bandwidth), as well as the desired operating temperature range of the final application.

On the market there are numerous crystals that satisfy all of the criteria described in this document. However, it is not possible and not intended to provide a complete list of all the supported manufacturers and part types in this document. Table 1 summarizes the verified, recommended crystals.

5. Recommended Crystal Types

Table 1. Recommended Crystal Types

Crystals						
Mfr	Freq	Type	CL	ESR max	Tolerance	Operating Temp.
NDK	26 MHz	NX2520SA 26 MHz EXS00A-CS06378	8 pF	60 Ω	+/- 10 ppm	-20 °C...+75 °C
NDK	26 MHz	NX2016SA 26 MHz EXS00A-CS06236	8 pF	60 Ω	+/- 10 ppm	-20 °C...+75 °C
NDK	30 MHz	NX2016SA 30 MHz EXS00A-CS06568	8 pF	60 Ω	+/- 25 ppm	-40 °C...+85 °C
NDK	32 MHz	NX2016SA 32 MHz EXS00A-CS06238	8 pF	60 Ω	+/- 25 ppm	-40 °C...+85 °C
NDK	26 MHz	NX2016SA 26 MHz EXS00A-CS07337	8 pF	120 Ω	+/- 50 ppm	-40 °C...+125 °C
NDK	30 MHz	NX2016SA 30 MHz EXS00A-CS07338	8 pF	120 Ω	+/- 50 ppm	-40 °C...+125 °C
TST	30 MHz	TZ1430A	10 pF	50 Ω	+/- 10 ppm	-20 °C...+70 °C
TST	26 MHz	TZ0661E	10 pF	60 Ω	+/- 20 ppm	-40 °C...+85 °C
Epson	30 MHz	FA-20H	10 pF	50 Ω	+/- 10 ppm	-40 °C...+85 °C
Epson	30 MHz	FA-128	10 pF	50 Ω	+/- 10 ppm	-40 °C...+85 °C
Abrakon	26 MHz	ABM10	10 pF	70 Ω	+/- 20 ppm	-20 °C...+70 °C
Abrakon	30 MHz	ABM10	10 pF	70 Ω	+/- 20 ppm	-20 °C...+70 °C
River	30 MHz	FCX-04	10 pF	50 Ω	+/- 20 ppm	-20 °C...+70 °C

Table 1. Recommended Crystal Types

ECS	30 MHz	ECS-300-8-36CKM	8 pF	50 Ω	+/- 10 ppm	-20 °C...+70 °C
AVX Corp	30 MHz	CX2520DB	8 pF	50 Ω	+/- 15 ppm	-10 °C...+70 °C

To obtain the proper radio configurations, it is recommended to use WDS and configure the crystal tolerances for both ends of the link within the Radio Configuration Application (see Figure 5).

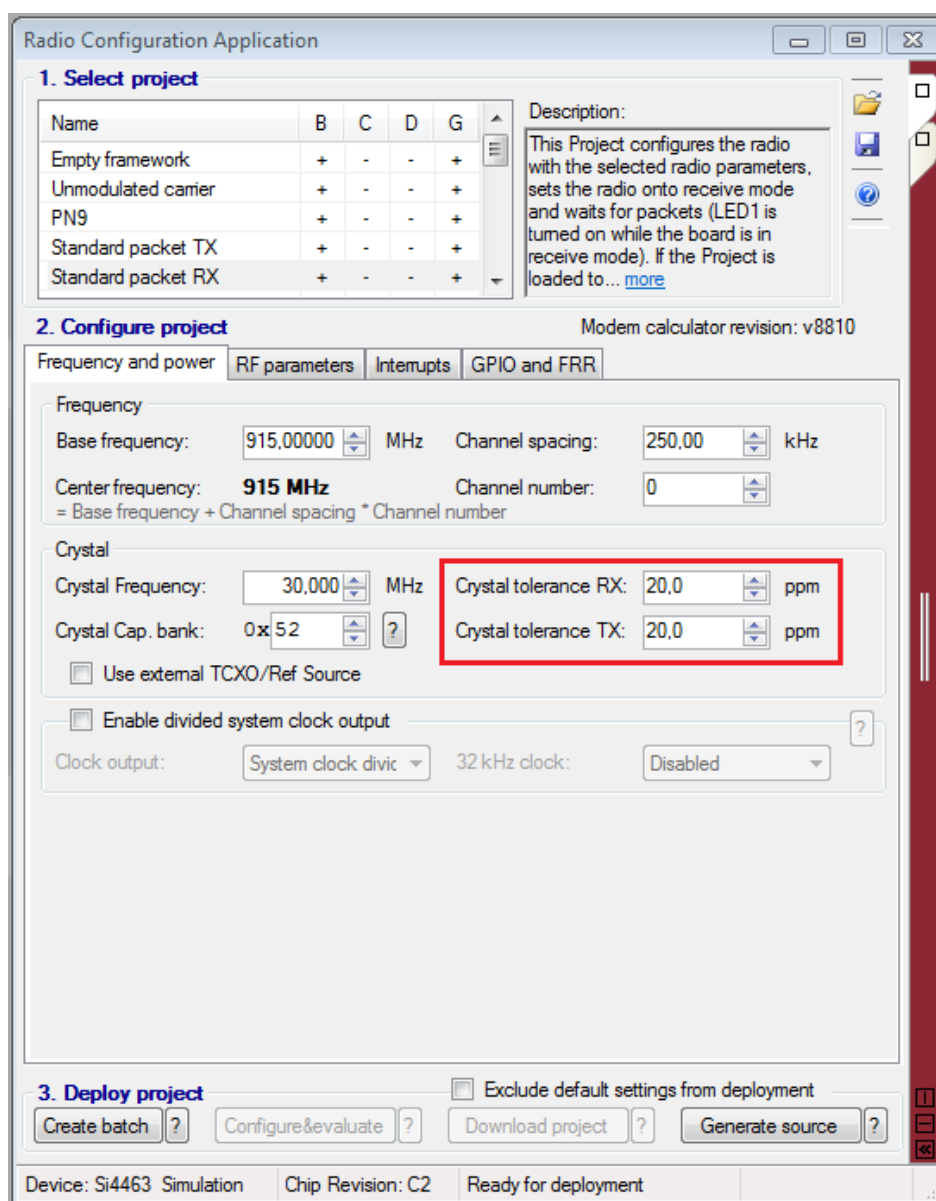

Figure 5. WDS Crystal Tolerance

6. Using an External Oscillator (TCXO)

In several narrow-band systems, the accuracy requirements cannot be achieved without compensating the temperature dependency of the crystal itself. A cost-effective method would be to utilize the on-chip temperature sensor and digitally adjust the crystal capacitance bank (GLOBAL_XO_TUNE API property) with a suitable software control loop. A more accurate but practical solution is to use a TCXO (temperature-compensated crystal oscillator).

A TCXO or external signal source can easily be used in place of a conventional XTAL and should be connected to the XIN pin. The incoming clock signal is recommended to have a peak-to-peak swing in the range of 600 mV to 1.4 V and ac-coupled to the XIN pin with a series capacitor. The maximum allowed swing on XIN is 1.8 V peak-to-peak. The XO capacitor bank should be set to 0 whenever an external drive is used on the XIN pin using the "GLOBAL_XO_TUNE" API property. In addition, the POWER_UP command should be invoked with the TCXO option whenever the external drive is used.

A TCXO or other external signal sources may introduce unwanted mixing products in the frequency spectrum (frequency offset from the RF carrier is typically equal to the crystal frequency). The level of these unwanted signals depends on the voltage amplitude at the XIN pin and the TX output power. The level of these spurious signals does not affect the compliance of the Si4x6x to most of the regulatory standards around the world up to +20 dBm (which is the maximum available output power of this chip family). However, certain applications may require the usage of an external power amplifier (for which the Si446x has built-in support). In this case, the level of these spurious signals might reach or exceed the limit raised against spurious signals by certain standards (like European ETSI for +27 dBm at 869.525 MHz).

In case of such an application using the Si4x6x chip revisions other than C (e.g., B0 or B1), there are optimized settings which provide additional suppression of these unwanted mixing products. To ensure a safe operation, the following process must be followed for the revision B chips (e.g., B0 or B1):

Transitioning from SLEEP to any active state:

1. Turn on the TCXO and wait for its settling time.
2. Transition from SLEEP to any active mode (SPI_ACTIVE, SPI_ACTIVE, READY, TUNE, RX, TX, etc.).
3. Send the following bytes to the radio via the SPI interface: "F1 F0 01 0A". The nSEL must be pulled low before the API command is sent and pulled high afterwards.

Transitioning from any active to SLEEP mode:

1. Send the following bytes to the radio via the SPI interface: "F1 F0 01 FA". The nSEL must be pulled low before the API command is sent and pulled high afterwards.
2. Transition to SLEEP mode.
3. Turn off the TCXO to save current.

The additional settings above do not need to be set for Si4x6x revision C chips (e.g., C0, C1, or C2).

To obtain the proper radio configurations, it is recommended to use WDS and set the "Use external TCXO/Ref source" option within the Radio Configuration Application (see Figure 6).

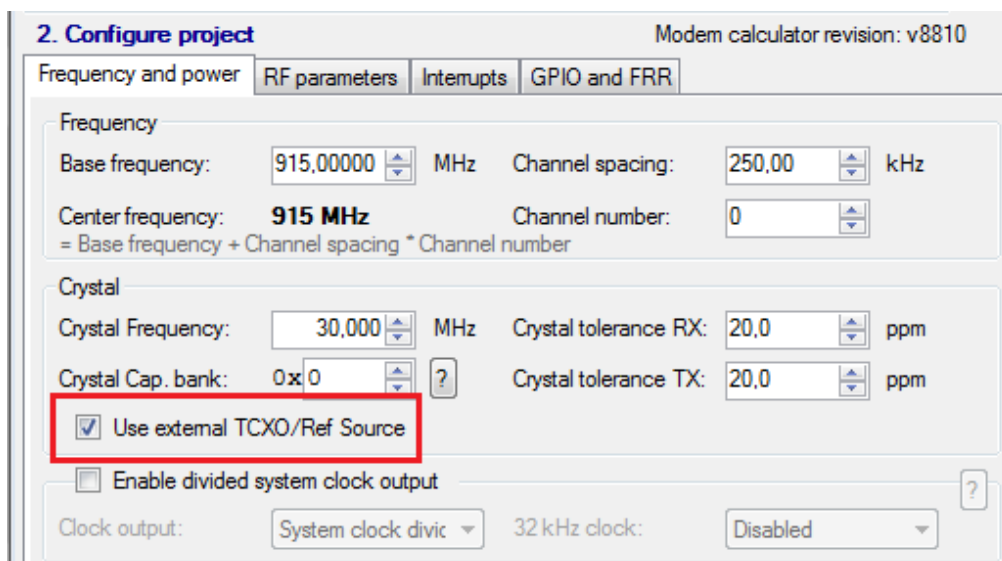

Figure 6. WDS setting for TCXO

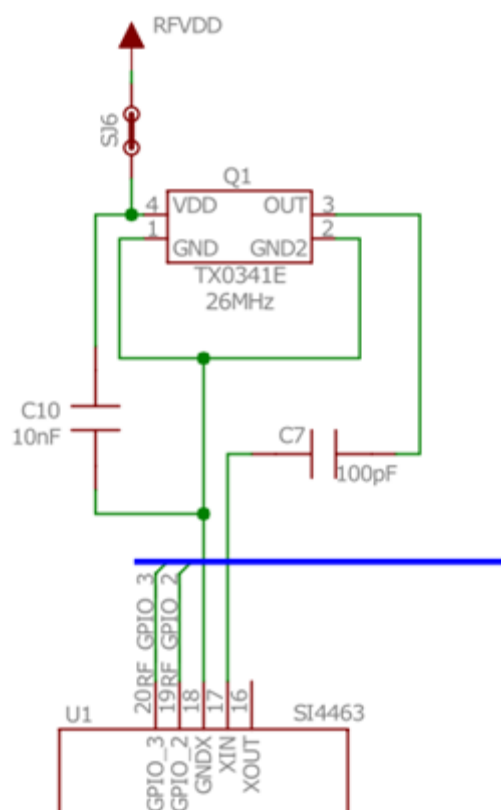

Figure 7. Reference Design Schematic with TCXO

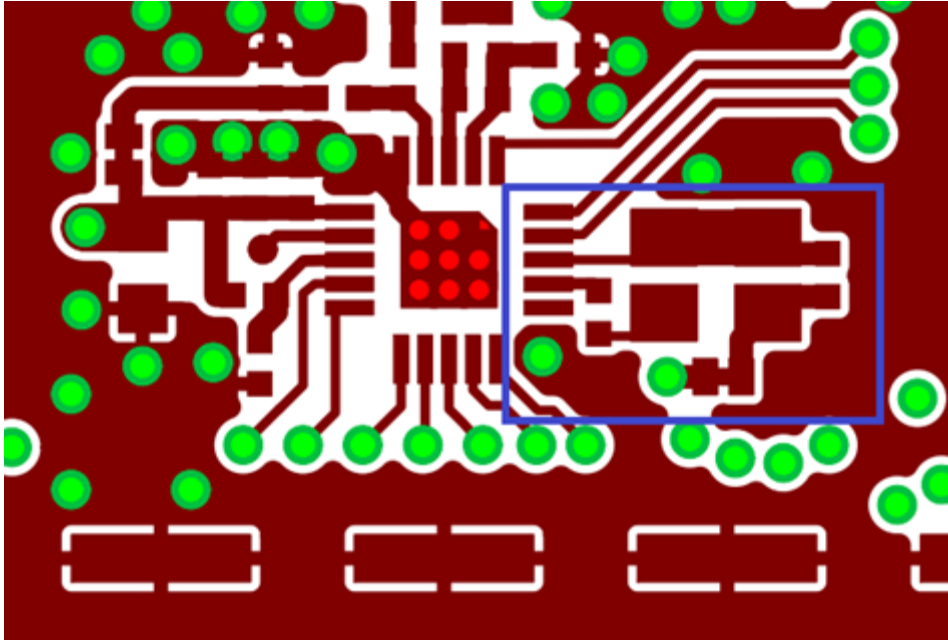

Figure 8. Reference Design Layout with TCXO

7. Recommended TCXO Types

Table 2 summarizes the recommended and verified TCXOs.

Table 2. Recommended TCXO Types

TCXO						
Manufacturer	Freq	Type	DC Current	Waveform	Tolerance	Operating Temp.
TST	30 MHz	TX0338A	2 mA	Clipped Sine	±2 ppm	-30 °C...+75 °C
TST	26 MHz	TX0341E	2 mA	Clipped Sine	±2 ppm	-40 °C...+85 °C
NDK	30 MHz	NT2520SB 30 MHz END4673A	1.5 mA	Clipped Sine	±2 ppm	-30 °C...+85 °C
NDK	26 MHz	NT2520SB 26 MHz END4673B	1.5 mA	Clipped Sine	±2 ppm	-30 °C...+85 °C
NDK	26 MHz	NT2016SA 26 MHz END4456A	1.5 mA	Clipped Sine	±2 ppm	-30 °C...+85 °C
NDK	26 MHz	NT3225SA 26 MHz END4605A	1.5 mA	Clipped Sine	±2 ppm	-30 °C...+85 °C
NDK	26 MHz	NT2016SA 26 MHz END4628A	1.5 mA	Clipped Sine	±3 ppm	-40 °C...+105 °C
NDK	30 MHz	NT2016SA 30 MHz END4628B	1.5 mA	Clipped Sine	±3 ppm	-40 °C...+105 °C
Epson	30 MHz	TG-5031CJ	2 mA	Clipped Sine	±2 ppm	-30 °C...+85 °C
Epson	26 MHz	TG-5035CJ	2 mA	Clipped Sine	±2 ppm	-30 °C...+85 °C
Murata/RFM	26 MHz	XTC7006G-4	1.5 mA	Clipped Sine	±2 ppm	-40 °C...+85 °C
Murata/RFM	30 MHz	XTC7002	2 mA	Clipped Sine	±2 ppm	-30 °C...+75 °C
Golledge	30 MHz	GTXO83	2 mA	Clipped Sine	±2.5 ppm	-30 °C...+75 °C

AN785

Revision 1.1 to Revision 1.2

- Added new part (Si4x55).
- Added Si4x6x revision C features.

Revision 1.2 to Revision 1.3

- Added new recommended crystal types and TCXO types to tables 1 and 2.



Smart.
Connected.
Energy-Friendly.



Products
www.silabs.com/products



Quality
www.silabs.com/quality



Support and Community
community.silabs.com

Disclaimer
Silicon Labs intends to provide customers with the latest, accurate, and in-depth documentation of all peripherals and modules available for system and software implementers using or intending to use the Silicon Labs products. Characterization data, available modules and peripherals, memory sizes and memory addresses refer to each specific device, and "Typical" parameters provided can and do vary in different applications. Application examples described herein are for illustrative purposes only. Silicon Labs reserves the right to make changes without further notice and limitation to product information, specifications, and descriptions herein, and does not give warranties as to the accuracy or completeness of the included information. Silicon Labs shall have no liability for the consequences of use of the information supplied herein. This document does not imply or express copyright licenses granted hereunder to design or fabricate any integrated circuits. The products are not designed or authorized to be used within any Life Support System without the specific written consent of Silicon Labs. A "Life Support System" is any product or system intended to support or sustain life and/or health, which, if it fails, can be reasonably expected to result in significant personal injury or death. Silicon Labs products are not designed or authorized for military applications. Silicon Labs products shall under no circumstances be used in weapons of mass destruction including (but not limited to) nuclear, biological or chemical weapons, or missiles capable of delivering such weapons.

Trademark Information
Silicon Laboratories Inc.®, Silicon Laboratories®, Silicon Labs®, SiLabs® and the Silicon Labs logo®, Bluegiga®, Bluegiga Logo®, Clockbuilder®, CMEMS®, DSPLL®, EFM®, EFM32®, EFR, Ember®, Energy Micro, Energy Micro logo and combinations thereof, "the world's most energy friendly microcontrollers", Ember®, EZLink®, EZRadio®, EZRadioPRO®, Gecko®, ISOModem®, Precision32®, ProSLIC®, Simplicity Studio®, SiPHY®, Telegesis, the Telegesis Logo®, USBXpress® and others are trademarks or registered trademarks of Silicon Labs. ARM, CORTEX, Cortex-M3 and THUMB are trademarks or registered trademarks of ARM Holdings. Keil is a registered trademark of ARM Limited. All other products or brand names mentioned herein are trademarks of their respective holders.



Silicon Laboratories Inc.
400 West Cesar Chavez
Austin, TX 78701
USA

<http://www.silabs.com>