

AN0016.0: Oscillator Design Considerations



This application note provides an introduction to the oscillators in MCU Series 0 or Wireless MCU Series 0 devices and provides guidelines in selecting correct components for their oscillator circuits.

The MCU Series 0 or Wireless MCU Series 0 devices contain two crystal oscillators: one low speed (32.768 kHz) and one high speed (4-50 MHz depending on the device, see datasheet for more information). Topics covered include oscillator theory and some recommended crystals for these devices.

KEY POINTS

- Crystal oscillators are more precise and stable, but are more expensive and start up more slowly than RC and ceramic oscillators.
- Learn what parameters are important when selecting an oscillator.
- Learn how to reduce power consumption when using an external oscillator.

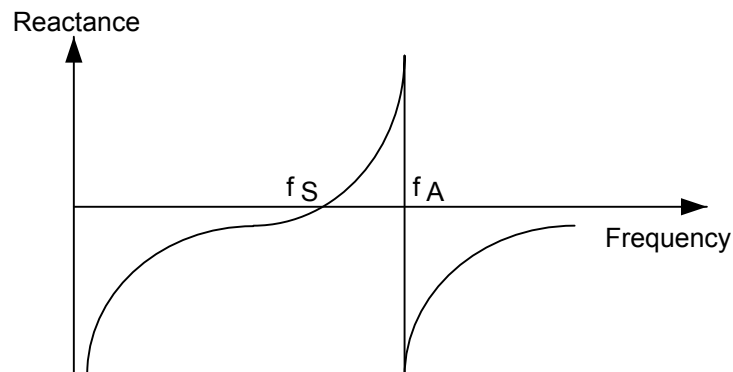

1. Device Compatibility

This application note supports multiple device families, and some functionality is different depending on the device.

MCU Series 0 consists of:

- EFM32 Gecko (EFM32G)
- EFM32 Giant Gecko (EFM32GG)
- EFM32 Wonder Gecko (EFM32WG)
- EFM32 Leopard Gecko (EFM32LG)
- EFM32 Tiny Gecko (EFM32TG)
- EFM32 Zero Gecko (EFM32ZG)
- EFM32 Happy Gecko (EFM32HG)

Wireless MCU Series 0 consists of:

- EZR32 Wonder Gecko (EZR32WG)
- EZR32 Leopard Gecko (EZR32LG)
- EZR32 Happy Gecko (EZR32HG)

2. Oscillator Theory

2.1 What is an Oscillator?

An oscillator is an electronic circuit which generates a repetitive, or periodic, time-varying signal. In the context of MCU Series 0 or Wireless MCU Series 0 devices, this oscillator signal is used to clock execution of instructions, digital logic, and communications in the device. There are multiple ways of generating such a signal, each with different properties that influence project cost, board size, and stability of the clock signal.

RC oscillators

RC oscillators are built from resistors, capacitors, and an inverting amplifier. They come at a low cost and have a shorter startup time than the crystal oscillator, but variations in component values over temperature make it difficult to precisely determine the oscillation frequency. The MCU Series 0 or Wireless MCU Series 0 devices provide at least three internal RC-oscillators: one high frequency RC oscillator (HFRCO), one low frequency RC oscillator (LFRCO), and one ultra low frequency RC oscillator (ULFRCO). In addition, an auxiliary high frequency RC oscillator (AUXHFRCO) is used for flash programming and debug trace. While the internal RC-oscillators will ensure proper operation of the MCU Series 0 or Wireless MCU Series 0 device, some applications require higher accuracy than these can provide.

Crystal oscillators

Crystal oscillators use the mechanical vibration of a crystal to generate the clock signal. Due to the molecular composition of the crystal matter and the angle of which the crystal is cut, this type of oscillator is very precise and stable over a wide temperature range. The most commonly used crystal is the quartz crystal. Producing quartz crystals requires very stable temperature and pressure conditions over a few weeks. This makes crystal oscillators more expensive than RC oscillators.

Ceramic resonators

Ceramic resonators operate in the same way as crystal oscillators. They are easier to manufacture and therefore cheaper than quartz crystals, but suffer from inferior precision in the oscillation frequency. As will be seen in subsequent chapters, the quality factor for ceramic resonators is lower than for crystal oscillators, which usually results in a faster startup time. This can be more important than precision in frequency for some applications.

This application note will focus on quartz crystals; however, the theory presented is also valid for ceramic resonators.

2.1.1 Piezoelectricity

Quartz crystals and ceramic resonators hold the direct piezoelectric property. This means an applied electric field will cause the crystal to deform. Conversely, a deformation of the crystal will cause a voltage across the terminals. Once the oscillator has started, the changing voltage on the terminals of the vibrating crystal is used as the clock signal.

2.2 Basic Principle of Oscillators

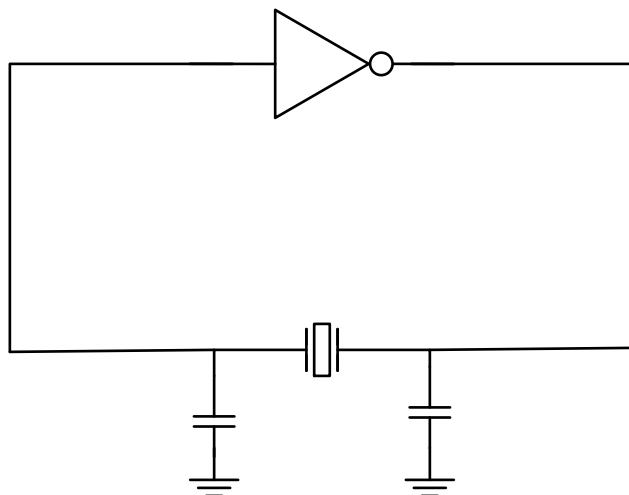

Figure 2.1. Simplified Feedback Oscillator Loop

The principle behind the oscillator is a positive feedback loop satisfying the Barkhausen condition: If the closed-loop gain is larger than unity and the total phase lag is 360° , the resulting closed-loop system is unstable and will self-reinforce. This is a necessary, but not sufficient, condition for oscillations to be present. When the necessary conditions are met, any disturbance (noise) in the oscillator will cause oscillations to start. The frequency that fulfills the Barkhausen condition is amplified the most, because it is in phase with the original signal.

The initial oscillations are very weak and it takes time to amplify the signal to the desired magnitude. When oscillations are established, only a small amount of energy is needed to compensate for losses in the circuit. Mathematically, a closed-loop gain of one is required to maintain steady state oscillations. The MCU Series 0 or Wireless MCU Series 0 relies on an internal regulator to adjust the closed-loop gain to unity when the clock signal reaches the desired amplitude.

[Figure 2.1 Simplified Feedback Oscillator Loop on page 4](#) shows that the oscillator circuitry consists of two parts; an amplification stage and a filter that decides which frequency experience a 360° phase lag. In the case of a crystal oscillator, the filter consists of the crystal and external load capacitors.

2.2.1 Startup time

The magnitude of the closed-loop gain has great influence on the startup time. With high gain, the number of times the signal has to be propagated around the loop to reach the desired amplitude is reduced. For fast startup, a high gain is preferred.

For the same reason, the oscillation frequency influences the startup time. A crystal in the kHz range would have a considerably longer startup time than a crystal in the MHz range because the time it takes to circulate the loop is longer. Typical startup times for the MCU Series 0 or Wireless MCU Series 0 is 200-400 ms for low frequencies and 200 μ s to 400 μ s in the high frequency domain.

2.3 Modeling the Crystal

The crystal can be described by the electrical equivalent circuit in [Figure 2.2 The Electric Equivalent Circuit of a Crystal on page 5](#).

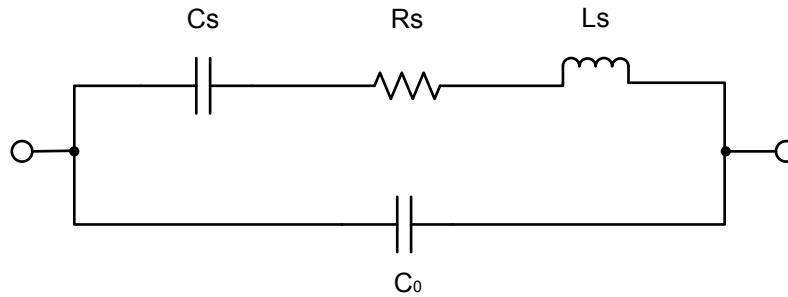

Figure 2.2. The Electric Equivalent Circuit of a Crystal

- C_S is the motional capacitance. It represents the piezoelectric charge gained from a displacement in the crystal.
- R_S is the motional resistance. It represents the mechanical losses in the crystal.
- L_S is the motional inductance. It represents the moving mass in the crystal.
- C_0 is the shunt capacitance between the electrodes and stray capacitance from the casing.

For low frequencies, the electrical equivalent circuit will exhibit capacitive behavior as depicted in [Figure 2.3 Reactance vs. Frequency on page 5](#). The presence of the inductor becomes more noticeable as the frequency, and thus the reactance, increases. Ignoring the shunt capacitance C_0 , the series resonance frequency is defined where the reactance of the inductor and capacitor cancels. At this frequency the crystal appears only resistive with no shift in phase. The series resonance frequency, f_S , therefore decides the values of C_S and L_S and can be calculated with the equation below. The series resonance frequency is the natural resonance frequency where the energy transformation between mechanical and electrical energy is most effective.

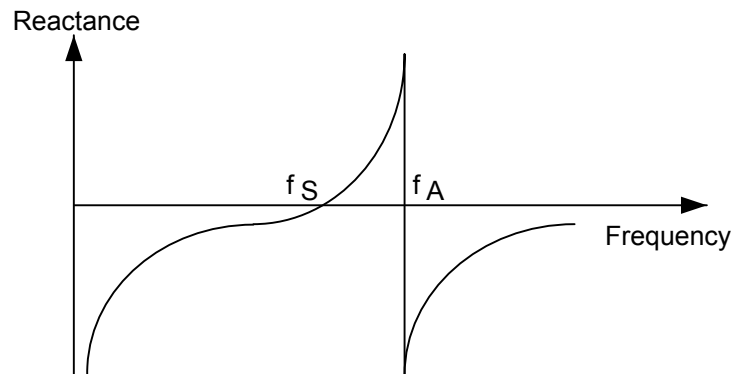

Figure 2.3. Reactance vs. Frequency

$$f_S = \frac{1}{\left(2 \times \pi \times \left(L_S \times C_S\right)^{\frac{1}{2}}\right)}$$

At higher frequencies, the equivalent circuit will appear inductive, which implies higher impedance. When the inductive reactance from the crystal cancels the capacitive reactance from shunt capacitance C_0 , another resonance frequency with zero phase shift exists. This frequency is called the anti-resonant frequency, f_A . At this frequency, the impedance is at its maximum. The inductance in the crystal and the shunt capacitance will feed each other and the lowest possible current draw is obtained.

$$f_A = \frac{1}{\left(2 \times \pi \times \left(L_S \times \frac{C_S \times C_0}{C_S + C_0}\right)^{\frac{1}{2}}\right)}$$

The range of frequencies between f_S and f_A is called the area of parallel resonance and is where the crystal will normally oscillate. At the resonant frequency, the phase lag in the feedback loop is provided by an amplifier with 180° phase lag and two capacitors with a combined 180° phase lag. In practice, the amplifier provides a little more than 180° phase shift, which means the crystal has to appear slightly inductive to fulfill the Barkhausen criterion.

2.3.1 Series and Parallel Resonant Crystals

Physically there is no difference between series and parallel resonant crystals. Series resonant crystals are specified to oscillate at the series resonant frequency where the crystal appears with no reactance. Because of this, no external capacitance should be present as this would lower the oscillating frequency to below the natural resonance frequency. These crystals are intended for use in circuits with no external capacitors where the oscillator circuit provides 360° phase shift.

Parallel resonant crystals require a capacitive load to oscillate at the specified frequency and this is the resonance mode required for MCU Series 0 or Wireless MCU Series 0 devices. MCU Series 0 or Wireless MCU Series 0 devices require external load capacitors. The exact oscillation frequency for a parallel resonant crystal can be calculated with the equation below, where C_L is the load capacitance seen by the crystal. C_L is therefore an important design parameter and is given in the datasheet for parallel resonant crystals.

$$f_P = f_S \left(1 + \frac{C_S}{2 \times C_L}\right)$$

3. MCU Series 0 or Wireless MCU Series 0 Crystal Oscillators

The MCU Series 0 or Wireless MCU Series 0 devices include a variety of oscillators, including fully internal low speed and high speed RC oscillators (not covered by this application note). These enable full operation in all energy modes without any external oscillator components. If the application requires a more accurate clock, the MCU Series 0 or Wireless MCU Series 0 devices include two crystal oscillators, the Low Frequency Crystal Oscillator (LFXO) and the High Frequency Crystal Oscillator (HFXO). These oscillators require an external clock or crystal and load capacitors connected to the crystal oscillator pins of the device. The LFXO supports crystals with a nominal frequency of 32.768 kHz, while the HFXO supports frequencies from 4 to 50 MHz depending on the device - see datasheet for more information. External oscillators which provide sine and square waves are also supported. See *AN0002: Hardware Design Considerations* for register settings and pin connections. Both the high and low frequency clock sources can be used simultaneously.

In the MCU Series 0 or Wireless MCU Series 0 oscillator circuits are designed as a Pierce oscillator as shown in [Figure 3.1 The Pierce Oscillator in the MCU Series 0 or Wireless MCU Series 0 on page 7](#).

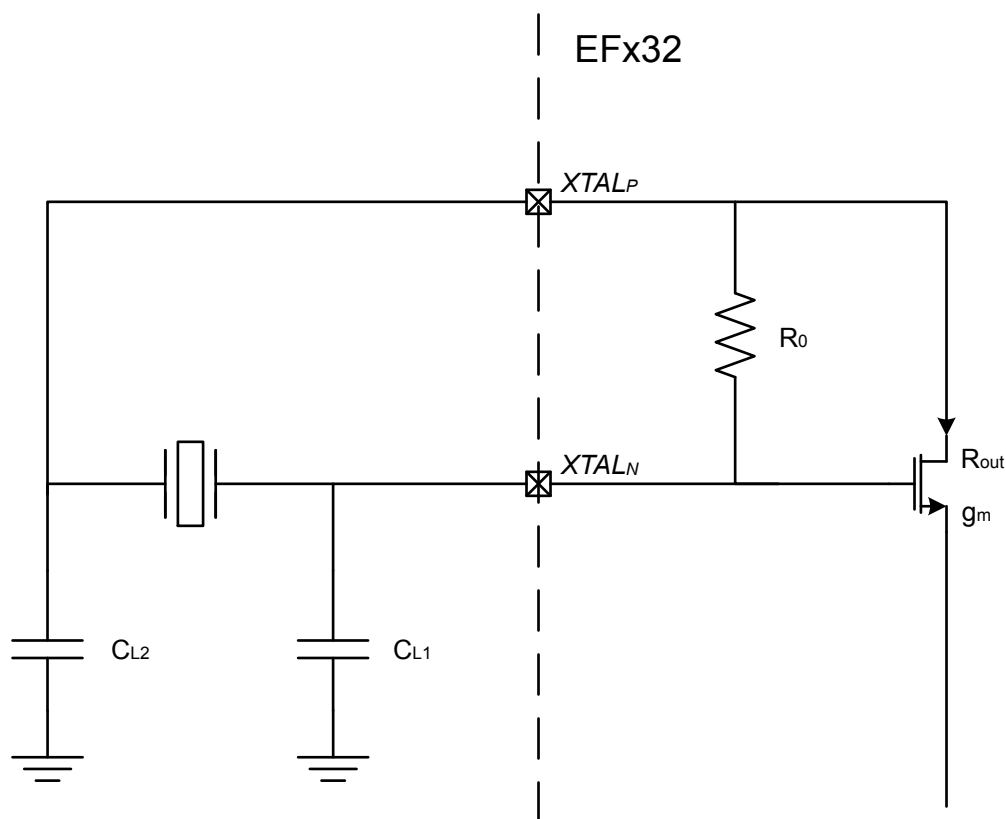

Figure 3.1. The Pierce Oscillator in the MCU Series 0 or Wireless MCU Series 0

The Pierce oscillator is known to be stable for a wide range of frequencies and for its low power consumption.

The MCU Series 0 or Wireless MCU Series 0 crystal oscillators use a relatively low oscillation amplitude, which can lead to a lower oscillation frequency than stated as the nominal value in the crystals datasheet. More information on this effect is given in [4.4 Frequency Pulling](#).

3.1 Timeout and Glitch Detection

To ensure that the XO clock signals are not used internally in the MCU Series 0 or Wireless MCU Series 0 before they are stable, both the HFXO and the LFXO include a configurable timeout (see *AN0002: Hardware Design Considerations* for details). When the XO starts up, the timeout counter will count to the configured number of cycles before the clock signal propagates to the internal clock trees and the digital logic.

For the HFXO of MCU Series 0 or Wireless MCU Series 0, there is also a glitch detector that can be enabled (HFXOGLITCHDETEN in CMU_CTRL). With this set, any glitches detected during the timeout period will result in the timeout counter starting over again. The clock will then not propagate until it has run a full timeout period without glitches. After the timeout period has passed successfully the glitch detector is turned off automatically to save power.

3.2 Oscillator Configuration in Configurator

The **[Hardware Configurator]** in Simplicity Studio contains a tool to help users configure both load capacitance and software settings for using the LFXO and the HFXO. Once the correct hardware configuration has been found the designer can output C-code which should be run in the application. It is important that the software settings from **[Hardware Configurator]** are used to ensure reliable operation of the oscillator.

3.3 External Clock and Buffered Sine Input

The HFXO and LFXO oscillators can be used as inputs for an externally generated digital clock signal. When using the oscillators in this way, connect the clock input to HFXTAL_N or LFXTAL_N. The max frequency of these inputs are limited by the max clock frequency of the device (see the device data sheet for more information). An externally buffered sine signal can also be applied to the HFXTAL_N or LFXTAL_N pin. The recommended amplitude of this signal is between 0.8 and 1.2 V_{pk-pk} , and the frequency must be the same as required when using crystals with the HFXO and LFXO (see *AN0002: Hardware Design Considerations* for register settings).

4. Crystal Parameters

4.1 Quality Factor

The quality factor Q is a measure of the efficiency or the relative storage of energy to dissipation of energy in the crystal. For the electrical-equivalent circuit, the equation below states the relation between R, C and Q. In practice, crystals with higher Q-values are more accurate, but have a smaller bandwidth for which they oscillate. Therefore, high Q-factor crystals will normally start slower than crystals with higher frequency tolerance. Typically, crystals have higher Q-factor than ceramic resonators. Crystals can therefore be expected to have a longer startup time than ceramic resonators.

$$Q = \frac{X_{L_S}}{R_S} = \frac{1}{(X_{L_S} \times R_S)} = \frac{1}{(2 \times \pi \times f \times C_S \times R_S)} = \frac{2 \times \pi \times f \times L_S}{R_S}$$

X_{L_S} and X_{C_S} are the reactance of L_S and C_S , respectively, at the operating frequency of the crystal.

4.2 Load Capacitance

As seen in the equation below, the two capacitors C_{L1} and C_{L2} provide capacitive load for the crystal. The effective load capacitance, C_L , as seen from the XTAL_N and XTAL_P pins on the MCU Series 0 or Wireless MCU Series 0 is the series combination of C_{L1} and C_{L2} through ground.

$$C_L = \frac{(C_{L1} \times C_{L2})}{(C_{L1} + C_{L2})} + C_{\text{stray}}$$

Where C_{stray} is the pin capacitance of the microcontroller and any parasitic capacitance, and can often be assumed in the range 2-5 pF. Right choice of C_L is important for proper operating frequency. Crystals with small load capacitance would typically start faster than crystals requiring a large C_L . Large load capacitors also increase power consumption. It is recommended to use a crystal with C_L as specified in [6. Recommended Crystals](#). The MCU Series 0 or Wireless MCU Series 0 device datasheets also contain more information on the allowed load capacitance range.

Note: The MCU Series 0 or Wireless MCU Series 0 devices require external load capacitors be connected between the XTAL_N and XTAL_P pins and ground.

4.3 Equivalent Series Resistance

The Equivalent Series Resistance is the resistance in the crystal during oscillation and varies with the resonance frequency. ESR, given by the equation below, will typically decrease with increasing oscillation frequency.

$$ESR = R_S \left(1 + \frac{C_0}{C_L} \right)^2$$

The HFXO/LFXO circuits of the MCU Series 0 or Wireless MCU Series 0 cannot guarantee startup of crystals with ESR larger than a certain limit. Please refer to the device datasheet for further details. The smaller the ESR, compared to this maximum value, the better gain margin for startup of the crystal which in turn reduces the startup time. Additionally, a small ESR value gives lower power consumption during oscillation.

Note that HF crystals have ESR of a few tens of Ohms as compared to the LF crystals which have ESR values normally measured in kOhm. Therefore a few Ohm of series resistance has more influence on the startup margin in the MHz range as compared to the kHz range.

4.4 Frequency Pulling

As the crystal oscillators in the MCU Series 0 or Wireless MCU Series 0 use a relatively low oscillation amplitude, the oscillation frequency can be lower than stated in the datasheet when using the suggested load capacitance. This offset is best found by measuring the resulting frequency when using the suggested load capacitance. The offset will be stable and not affected by temperature, voltage or aging. If it is desirable to achieve the nominal frequency given for the crystal, there are two options:

- Option A — Order a crystal from the crystal vendor that has a nominal frequency equal to the frequency you want to achieve plus the measured offset frequency.
- Option B — It is possible to slightly alter the oscillation frequency of a crystal by adjusting the load capacitance (C_{L1} and C_{L2}). The pullability of the oscillation system refers to which extent it is possible to tune the resonance frequency of the crystal by changing these values. The crystal sees these capacitors in series through ground, parallel to the closed loop. They will therefore slightly alter the anti-resonance frequency of the crystal. The equation below shows the pullability in terms of frequency change in ppm per change in combined load capacitance in pF.

$$\text{Average pullability (ppm/pF)} = \frac{C_S \times 10^6}{2 \times (C_0 + C_L)^2}$$

4.5 Drive Level

Drive level is a measure of the power dissipated in the crystal. The crystal manufacturer should specify the maximum power dissipation value tolerated by the crystal in the crystal datasheet. Exceeding this value can damage the crystal.

$$DL = ESR \times I^2$$

I is the RMS current flowing through the crystal. An external resistor can be added to limit the drive level if necessary; however this is not recommended unless DL is too high since it reduces the gain margin and increases power consumption of the oscillator.

4.6 Minimum Negative Resistance

A critical condition for oscillations to build up requires the energy supplied to exceed the energy dissipated in the circuit. In other words, the negative resistance of the amplifier has to exceed the equivalent series resistance in the crystal. An approximate formula for negative resistance is given in the equation below.

$$R_{\text{neg}} = \frac{-g_m}{(2 \times \pi \times f)^2 \times C_{L1} \times C_{L2}}$$

Where g_m is the transconductance of the oscillator circuitry. To ensure safe operation over all voltage and temperature variations, the lowest allowed R_{neg} is given by the equation below.

$$-R_{\text{neg}} > 2 \times ESR_{\text{max}}$$

If the negative resistance is not high enough to satisfy this criterion, another crystal with lower ESR and/or load capacity requirements should be chosen. The XO Configurator in [Hardware Configurator] in Simplicity Studio is able to calculate the R_{neg} value for your design based on the load and shunt capacitance, internal loss and frequency. The equation above shows an approximate formula for this calculation which excludes shunt capacitance and internal loss.

4.7 Frequency Stability

Frequency stability is the maximum frequency deviation from the specified oscillating frequency over the given operating temperature range.

4.8 Frequency Tolerance

Frequency tolerance is the maximum frequency deviation from the specified oscillating frequency at 25 °C. This parameter gives an indication of variations between individual crystals.

4.9 PCB Layout

To minimize noise sensitivity caused by parasitic antenna and spurious coupling phenomena, the distance between the crystal, capacitors (when needed), and the MCU Series 0 or Wireless MCU Series 0 oscillator pins should be as short as possible. If it is not possible to place the external oscillator components close to the oscillator pins, care should be taken when routing these signals. Avoid long traces underneath the MCU Series 0 or Wireless MCU Series 0 package and other circuitry that could create spurious coupling with logic activity. Also avoid routing any other signals through the crystal area.

The ground side of the two capacitors (if external capacitors are needed) must be connected to ground. These connections should be as short as possible and of equal length for each of the capacitors. Ensure that the ground plane underneath the oscillator is of good quality. Do not use a separate ground plane under the oscillator with a narrow connection to the reference ground as this can act as an antenna. To avoid coupling from surrounding signal traces, it is a good practice to place a grounded guard ring around the oscillator and its components.

4.10 Software Configuration

The MCU Series 0 or Wireless MCU Series 0 allows for run-time configuration of the transconductance (g_m) of the HFXO and the LFXO during oscillation build-up. The following bit fields are used:

HFXO

HFXOBOOST[1:0] in CMU_CTRL

LFXO

- LFXOBOOST in CMU_CTRL
- REDLFXOBOOST in EMU_AUXCTRL (only available in EFM32GG devices)

The recommended settings for these bits depend on the load and shunt capacitances of the oscillator design. The LFXO/HFXO configurator in the **[Hardware Configurator]** in Simplicity Studio creates C-code that sets these configuration bits correctly according to the frequency, maximum ESR, shunt and load capacitance of the crystal. It is important that these recommendations are followed as incorrect settings can lead to unreliable operation of the crystal oscillator.

5. Reducing Power Consumption

The power consumption of the crystal oscillator is mostly determined by the drive level of the oscillator. This equals the power dissipated in the crystal as given in the equation below.

$$DL = \frac{1}{2} \times ESR \times (2 \times \pi \times f \times V_{pp} \times (C_0 + C_L))^2$$

V_{pp} is the peak to peak voltage across the crystal at the resonance frequency.

Because the internal buffer draws some current regardless of clock frequency, the average power consumption per MHz is usually lower for high clock frequencies. In the energy conscious sense it is therefore favorable to alternate between short periods in run mode with HFXO enabled and lower energy modes where HFXO is not running. Since the startup time depends on clock frequency, high frequency crystals are recommended to reduce the startup time.

During startup the current consumption is higher than after oscillations have stabilized. A short startup time reduces the period in which the current consumption of the oscillator is high and is therefore essential if the oscillator is frequently switched on and off. In general one would like the circuit to be operational as fast as possible and a fast startup time is therefore favorable. Crystals with low ESR and load capacitance typically have the shortest startup time and consume the least amount of power.

Energy consumption can be reduced by choosing an HFXO crystal in the lower frequency range in applications where entering a deeper sleep mode is not feasible.

6. Recommended Crystals

6.1 General Notes for Crystal Selection

When deciding upon which crystal to employ, the following considerations could be helpful to ensure a proper functioning oscillator.

Precision

High quality crystals are very precise, but come at a higher cost. Ceramic resonators are cheaper, but less precise. However, if no special precision is needed, the internal RC oscillators consume less power at the same frequency. Consult the device datasheet for details.

Operating environment

Temperature, humidity, and mechanical vibration affect the stability properties. For crystals, define what crystal cut is most appropriate for the application. For most applications, AT cut is an excellent choice due to good temperature stability over a wide temperature range. SC cut has good stability when exposed to mechanical vibrations, but suffers from humidity and temperature changes. Many more cuts with different properties exists.

Package

Surface mount or through-hole. If size is critical, define maximum package dimensions.

Find load capacitors

If $C_{L1, L2}$ is within range specified by the crystal datasheet, check if it meets a standard capacitor value. If not, use the nearest value available. A variable capacitor can be used to pull the correct frequency if desired.

Calculate negative resistance

If the magnitude of the negative resistance is less than $2xESR_{max}$, then find another crystal or adjust the load capacitance.

The recommended crystals are chosen from a selection of popular crystals with different ESR, cost, frequency stability, and tolerance. By examining the list of considerations above, one should be able to find a suitable crystal.

All the recommended crystals are fundamental mode, as is recommended for MCU Series 0 or Wireless MCU Series 0.

6.2 Crystal Specifications for MCU Series 0 or Wireless MCU Series 0

Table 6.1. 48 MHz Crystals

Mfg	Part	ESR (Ω)	C ₀ (pF)	C _L (pF)	Tolerance (ppm)	Footprint (mm)
Abracon	ABM2-48.000MHZ-D4YF-T	50	7	18	30	8.0 x 4.5
Abracon	ABM7-48.000MHZ-D-2-Y-F-T	70	7	18	20	6.0 x 3.5
Abracon	ABM8G-48.000MHZ-18-D2Y-T	50	7	18	20	3.2 x 2.5
Abracon	ABM10-48.000MHZ-D30-T3	70	7	10	30	2.5 x 2.0
Abracon	ABM11-48.000MHZ-D2X-T3	60	7	10	20	2.0 x 1.6
ECS Inc	ECS-480-18-23A-EN-TR	40	7	18	30	6.0 x 3.5
NDK	NX5032GA-48.000MHZ	50	—	8	20	5.0 x 3.2
River Eletec	FCX-06-48M	50	7	10	20	2.0 x 1.6

Table 6.2. 32 MHz Crystals

Mfg	Part	ESR (Ω)	C ₀ (pF)	C _L (pF)	Tolerance (ppm)	Footprint (mm)
ECS Inc	ECS-320-20-30B-DU	30	5	20	30	5.0 x 3.2
TXC	7B-32.000MAAJ-T	40	5	18	30	5.0 x 3.2
Abracon	ABM8G-32.000MHZ-B4Y-T	50	5	10	30	3.2 x 2.5
Citizen	CS325H-32.000MEDQ-UT	50	5	10	10	3.2 x 2.5
NDK	NX2520SA-32.000000MHZ	50	—	10	10	2.5 x 2.0
NDK	NX3225SA-32.000000MHZ	50	—	8	15	3.2 x 2.5
NDK	NX5032GA-32.000000MHZ	50	—	8	50	5.0 x 3.2
NDK	NX8045GB-32.000000MHZ	50	—	8	50	8.0 x 4.5
River Eletec	FCX-06-32M	50	7	10	20	2.0 x 1.6

Table 6.3. 4 MHz Crystals

Mfg	Part	ESR (Ω)	C ₀ (pF)	C _L (pF)	Tolerance (ppm)	Footprint (mm)
CTS	ATS040SM-T	120	7	20	30	HC49
Abracon	ABLS2-4.000MHZ-D4Y-T	180	7	18	30	HC49
Abracon	ABLS-4.000MHZ-B2-T	180	7	18	20	HC49
Fox Electronics	FQ1045A-4.000	150	7	20	30	10.0 x 4.5
Fox Electronics	FOXSDLF/040	200	7	20	50	13.9 x 5.0
TXC	9C-4.000MAAJ-T	150	7	18	30	HC49

Table 6.4. 32768 Hz Crystals

Mfg	Part	ESR (k Ω)	C ₀ (pF)	C _L (pF)	Tolerance (ppm)	Footprint (mm)
Epson Toyocom	MC-405 32.7680K-A0	35	0.85	12.5	20	10.4 x 4.0
Epson Toyocom	MC-306 32.7680K-A0	50	0.9	12.5	20	8.0 x 3.8
Abracon	ABS10-32.768KHZ-1-T	70	1	12.5	10	4.9 x 1.8
Citizen	CM315-32.768KEZF-UT	70	1.05	12.5	10	3.2 x 1.5
Citizen	CFS206-32.768KDZF-UB	35	1.35	12.5	20	Cylinder
Fox Electronics	FX135A-327	70	1	12.5	20	3.2 x 1.5
Golledge	GSWX26	35	1.35	12.5	20	Cylinder
River Eletec	TFX-02SCL125	70	1.4	12.5	20	3.2 x 1.5

7. Revision History

7.1 Revision 1.30

2017-12-20

Split application note into AN0016.0 and AN0016.1 for MCU Series 0 or Wireless MCU Series 0 and MCU Series 1 or Wireless SoC Series 1 device families, respectively.

Updated recommended crystals for MCU Series 1 or Wireless SoC Series 1 (AN0016.1).

Improved graphics.

Added MCU Series 1 or Wireless SoC Series 1 LFXO GAIN recommendations.

Updated/added TCXO information, including recommended input voltage and phase noise measurements (AN0016.1).

7.2 Revision 1.29

2017-6-30

Moved the device compatibility information from the front page to [1. Device Compatibility](#).

Updated the references to the various device families.

7.3 Revision 1.28

2017-2-08

Updated content for new naming convention.

Updated to add a new crystal option and a CO column.

7.4 Revision 1.27

2016-5-18

Updated the Kyocera crystal ESR value in .

7.5 Revision 1.26

2016-5-13

Updated the Kyocera crystal information in and added a new TaiSaw crystal to .

Changed f_a to f_A in [Figure 2.3 Reactance vs. Frequency on page 5](#).

7.6 Revision 1.25

2015-11-13

Added support for the Wireless SoC Series 1

7.7 Revision 1.24

2015-10-23

Formatting update

Added support for MCU Series 1

7.8 Revision 1.23

2013-10-14

New cover layout

7.9 Revision 1.22

2013-05-08

Added crystals from River Eletec Corporation.

Removed DL numbers for recommended crystals as they were misleading.

7.10 Revision 1.21

2012-04-18

Corrected typos in XO Configurator description.

7.11 Revision 1.20

2012-04-03

Updated recommendations on minimum negative resistance and removed recommendations on gain margin.

Added information on timeout counter and glitch detection.

Added PCB layout recommendations.

Added information on external clock and buffered sine input.

Added information on XO Configuration in energyAware Designer. Removed recommendations on how to use LFXOBOOST in CMU_CTRL as this is now covered by the eA Designer.

Removed crystal selection spreadsheet.

Added recommended 48 MHz crystals.

7.12 Revision 1.10

2011-08-10

Updated recommendations on use of LFXOBOOST.

Updated recommended crystals in document and spreadsheet for LFXO.

7.13 Revision 1.00

2010-07-20

Initial revision.

Silicon Labs

Simplicity Studio™4



Simplicity Studio

One-click access to MCU and wireless tools, documentation, software, source code libraries & more. Available for Windows, Mac and Linux!



IoT Portfolio
www.silabs.com/IoT



SW/HW
www.silabs.com/simplicity



Quality
www.silabs.com/quality



Support and Community
community.silabs.com

Disclaimer

Silicon Labs intends to provide customers with the latest, accurate, and in-depth documentation of all peripherals and modules available for system and software implementers using or intending to use the Silicon Labs products. Characterization data, available modules and peripherals, memory sizes and memory addresses refer to each specific device, and "Typical" parameters provided can and do vary in different applications. Application examples described herein are for illustrative purposes only. Silicon Labs reserves the right to make changes without further notice and limitation to product information, specifications, and descriptions herein, and does not give warranties as to the accuracy or completeness of the included information. Silicon Labs shall have no liability for the consequences of use of the information supplied herein. This document does not imply or express copyright licenses granted hereunder to design or fabricate any integrated circuits. The products are not designed or authorized to be used within any Life Support System without the specific written consent of Silicon Labs. A "Life Support System" is any product or system intended to support or sustain life and/or health, which, if it fails, can be reasonably expected to result in significant personal injury or death. Silicon Labs products are not designed or authorized for military applications. Silicon Labs products shall under no circumstances be used in weapons of mass destruction including (but not limited to) nuclear, biological or chemical weapons, or missiles capable of delivering such weapons.

Trademark Information

Silicon Laboratories Inc.®, Silicon Laboratories®, Silicon Labs®, SiLabs® and the Silicon Labs logo®, Bluegiga®, Bluegiga Logo®, Clockbuilder®, CMEMS®, DSPLL®, EFM®, EFM32®, EFR®, Ember®, Energy Micro, Energy Micro logo and combinations thereof, "the world's most energy friendly microcontrollers", Ember®, EZLink®, EZRadio®, EZRadioPRO®, Gecko®, ISOModem®, Micrium, Precision32®, ProSLIC®, Simplicity Studio®, SiPHY®, Telegesis, the Telegesis Logo®, USBXpress®, Zentri, and others are trademarks or registered trademarks of Silicon Labs. ARM, CORTEX, Cortex-M3 and THUMB are trademarks or registered trademarks of ARM Holdings. Keil is a registered trademark of ARM Limited. All other products or brand names mentioned herein are trademarks of their respective holders.



Silicon Laboratories Inc.
400 West Cesar Chavez
Austin, TX 78701
USA

<http://www.silabs.com>