

# **WF111 DEVELOPMENT KIT**

DATA SHEET

Friday, 14 September 2012

Version 1.1



## VERSION HISTORY

Version	Comment
1.0	First version
1.1	Minor updates

## TABLE OF CONTENTS

1	Product description .....	5
2	Board Description .....	6
2.1	WF111 Wi-Fi Module .....	6
2.2	Configurable I/O Ports .....	7
2.3	Debug SPI Interface .....	7
2.4	<i>Bluetooth</i> co-existence .....	7
2.5	SDIO/SDIO SPI/CSPI Host Connection .....	8
2.6	Board Powering .....	8
2.7	Jumper Header .....	8
2.8	LEDs .....	8
2.9	Resistor Jumpers .....	9
2.10	Current Measurement Point.....	10
3	Board Layout .....	11
4	Contact Information .....	12

# 1 Product description

## DESCRIPTION

DKWF111 is intended for evaluating the WF111 Wi-Fi module and as a basis for product development. The board can be inserted directly into an SDIO card slot, or a pin header or wires can be soldered to the board for alternative connections into the test system or application.

The WF111 is a fully integrated single 2.4GHz band 802.11 b/g/n module, intended for portable and battery powered applications, where Wi-Fi connectivity is needed. WF111 integrates an IEEE 802.11 b/g/n radio, antenna or U.FL antenna connector and SDIO or CSPI host interfaces.

The WF111 provides a low cost and simple Wi-Fi solution for devices that run an operating system and a TCP/IP stack on-board, but still offers the benefits of a module – small form factor, easy integration and certifications. Bluegiga also provides WF111 drivers for the Linux operating system.

The WF111 has hardware support for Wi-Fi encryption protocols and for various co-existence schemes which enables exceptional performance during simultaneous use of IEEE 802.11 and *Bluetooth* with a single antenna.

## KEY FEATURES:

- SDIO host connection
- Two switch mode converters
- Current measurement voltage output

## PHYSICAL OUTLOOK:

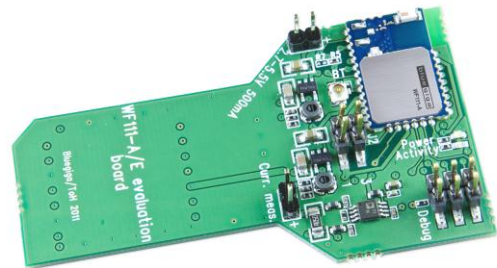
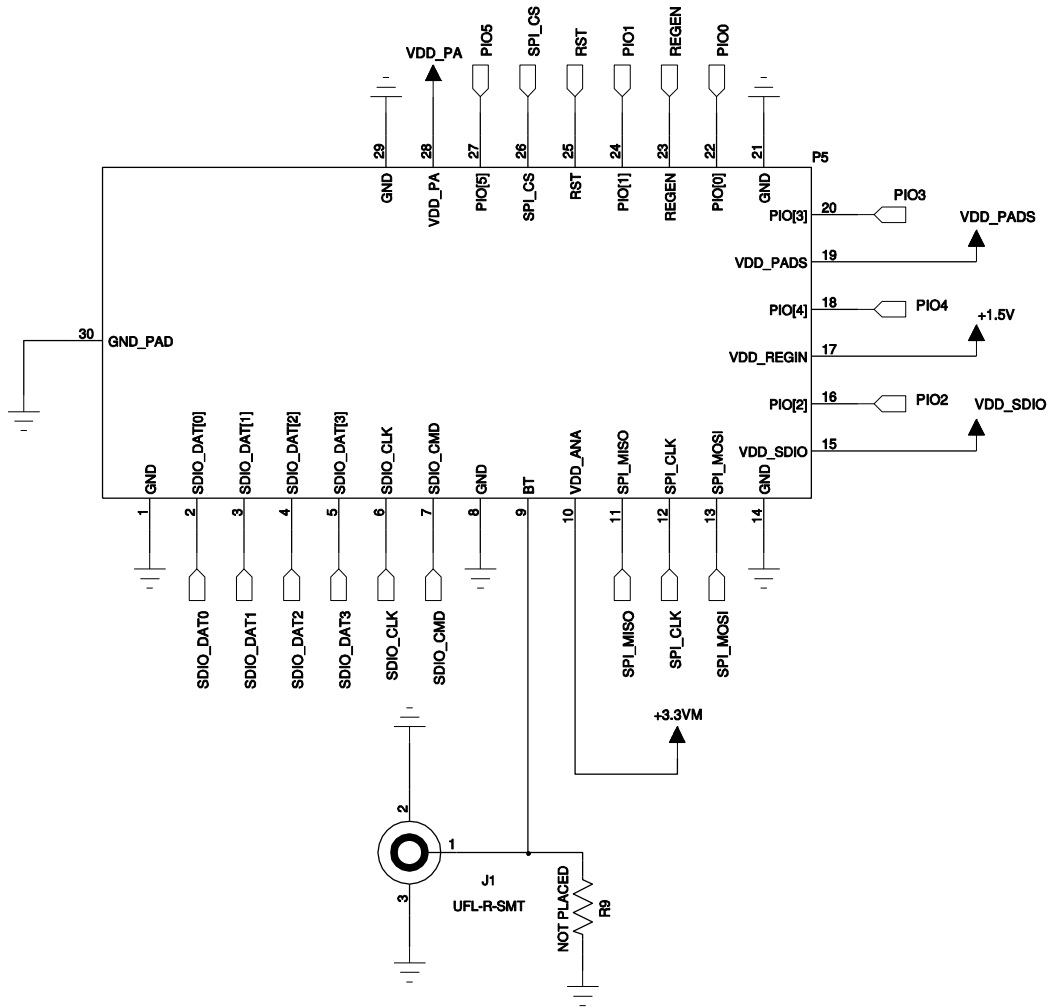

Figure 1: DKWF111

## 2 Board Description

### 2.1 WF111 Wi-Fi Module



Bluetooth coexistence antenna input

Figure 2: WF111 Wi-Fi module example schematic

DKWF111 contains a WF111-A module variant with an internal chip antenna.

## 2.2 Configurable I/O Ports

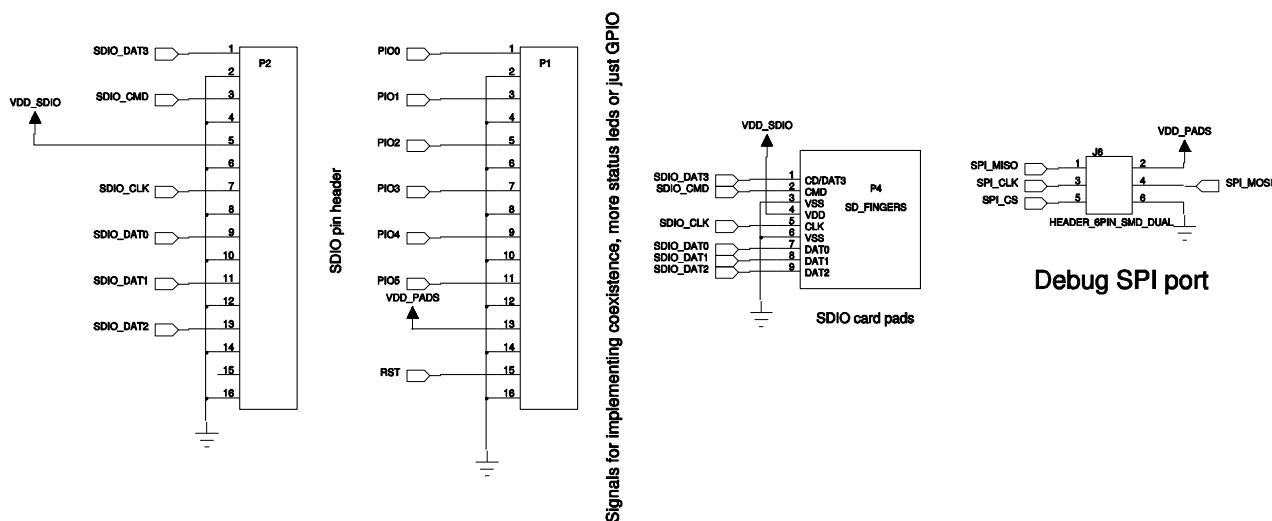

A number of programmable bi-directional input/outputs (I/O) are provided on a number of pads on the board, arranged for a surface mounted pin header that can be soldered on if needed. PIO[0:5] are powered from VDD\_PADS.

PIO lines can be configured through software to have either weak or strong pull-ups or pull-downs. All PIO lines are configured as inputs with weak pull-downs at reset. Configuration is done through the settings file (MIB) uploaded through the host connection at device configuration.

In addition to PIO, the lines can be configured as interrupt request lines, wake-up lines from sleep modes, status led drivers with multiple internally generated modes, general I/O pins controlled by the host, *Bluetooth* co-existence interface or as a 32.768 kHz sleep clock input.

## 2.3 Debug SPI Interface

A header is provided for the module debug bus for certification RF. Access to internal settings and test modes is available using a CSR compatible SPI adapter and UniTest-software.

For more information, please contact Bluegiga's technical support.

## 2.4 Bluetooth co-existence

Industry standard 2-wire and 3-wire, as well as Unity-3, Unity-4, Unity-3e co-existence schemes are supported as well as the Unity+ -extension, and the associated signals are available. The PIO pads can be configured for these functions among others. The co-existence parameters are set through the settings file uploaded through the host connection.

A U.FL connector is also present for antenna sharing using the module internal RF switch.



## 2.9 Resistor Jumpers

There are three places for 0 ohm resistors on board, with two populated. These can be used to change some functionality of the board.

R6 connects the module 3.3V power supply to the VDD\_PADS supply line, which acts as the logic level reference for the PIO lines. If an external system running at a different voltage is required to be connected to the PIO lines, R6 can be removed and the reference supply voltage fed to the PIO header supply pad.

R5 connects the module power amplifier supply to the switch mode regulator 3.3V output. If it is necessary to connect the PA supply directly to the input (testing total consumption while powering directly from a lithium battery, for example), the 0 ohm resistor can be moved from R5 to R7. The power amplifier is recommended to be supplied with a voltage from 2.7V to 4.8V, with an absolute maximum of 5.5V (set by the switch mode regulator input). Please note that this will remove the power amplifier from behind the current consumption measurement circuit.



## 2.10 Current Measurement Point

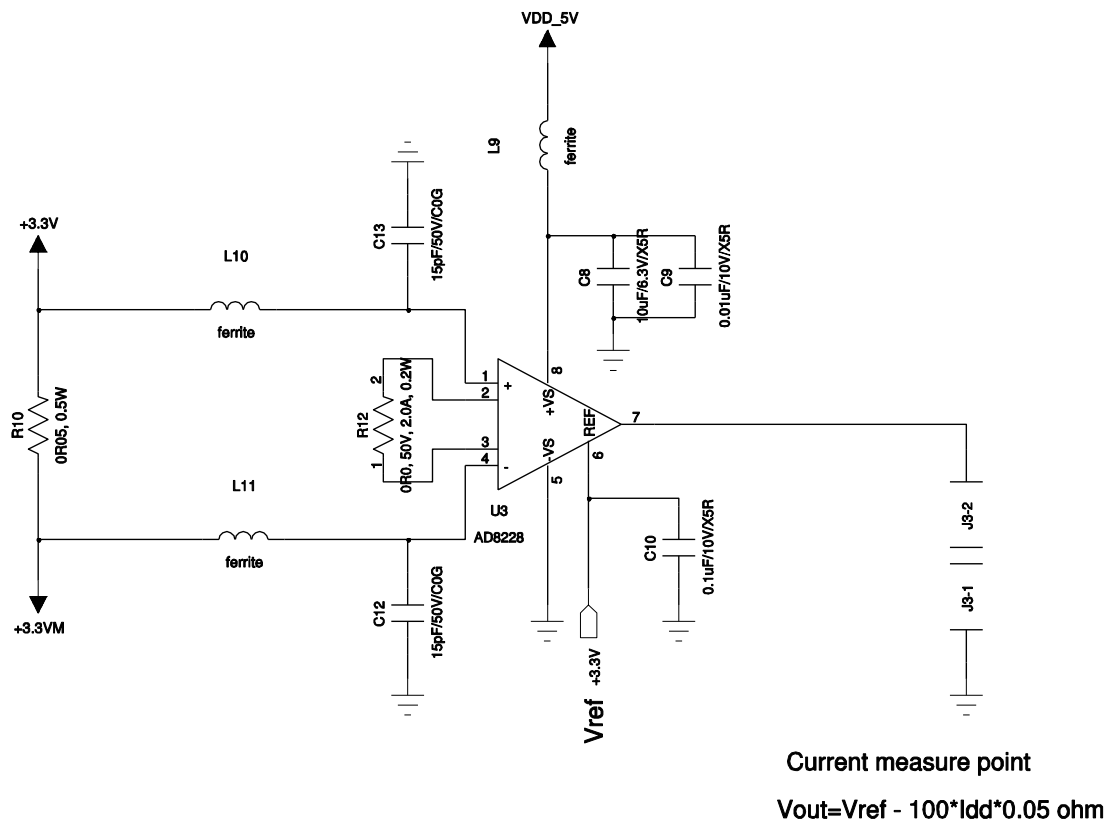

A two pin header is provided for measuring module momentary current consumption. Due to the dual voltage requirement of the module, the measurement point only measures 3.3V consumption, including the consumption and conversion losses of the switch mode converter providing the 1.5V core supply voltage. The header gives the voltage dropped over a high-side series resistor, amplified suitably and referred to the 3.3V voltage. The voltage relates to the current consumption with the following equation:

$$I_{\text{module}} = (3.3\text{V} - V_{\text{out}})/5$$

For example, a momentary reading of 2.6V would imply a current draw of 140mA.

An oscilloscope can be connected to this header to find the power consumption profiles of common use cases in different use cases.

Detaching the jumper connecting the REGEN signal lowers the total consumption of the module and the regulator to about 80µA. With the REGEN jumper removed the voltage across the measurement jumper can be used to calibrate the current measurement reference.

### 3 Board Layout

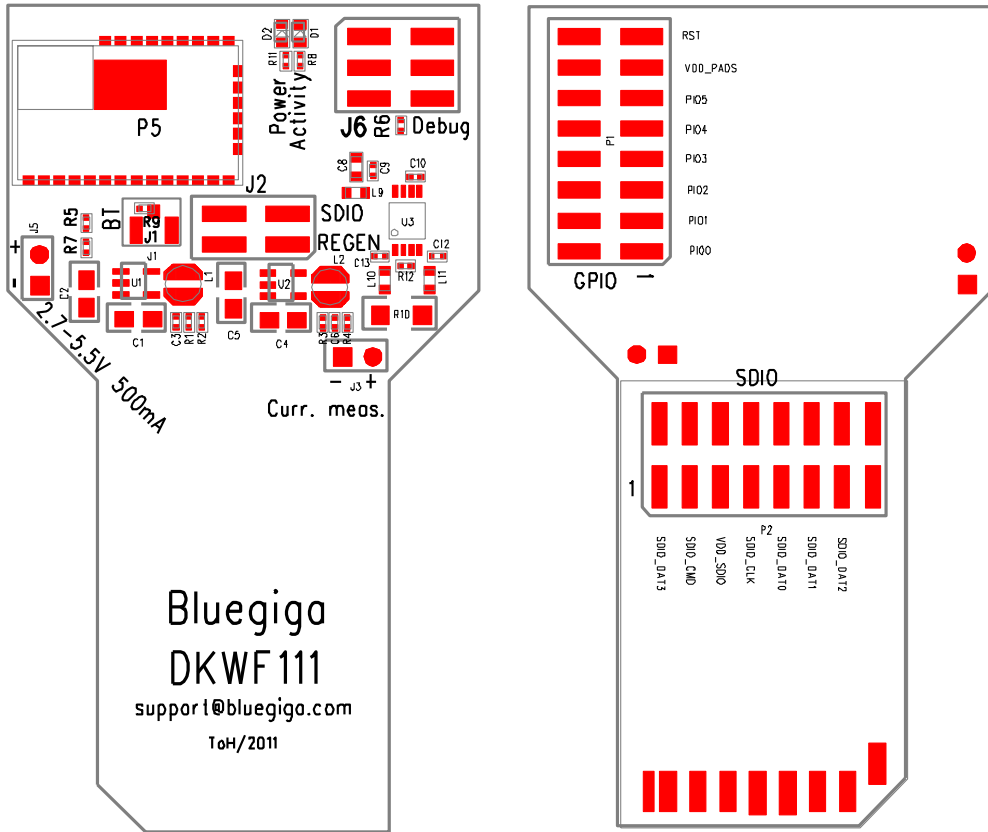

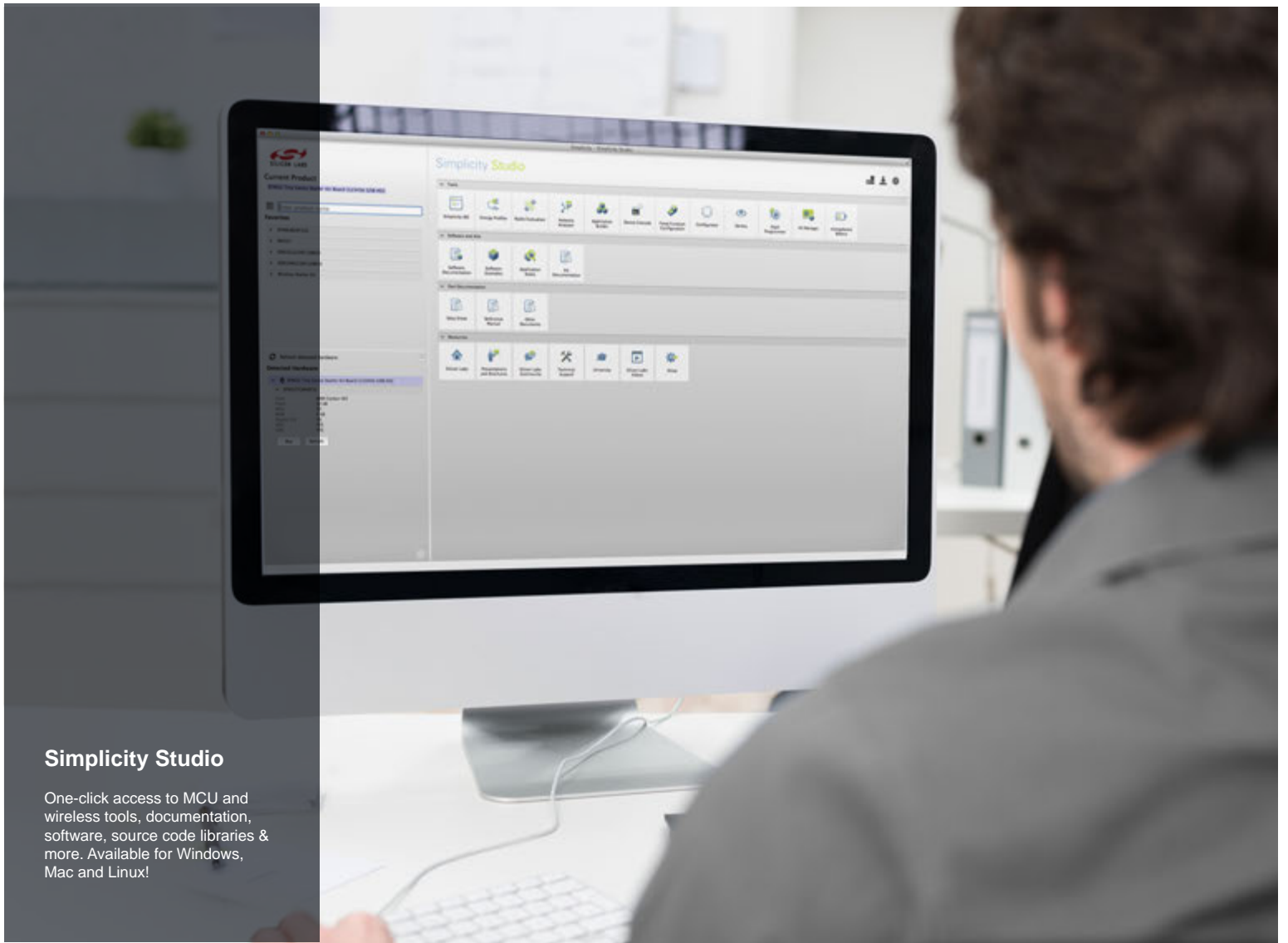

## Simplicity Studio

One-click access to MCU and wireless tools, documentation, software, source code libraries & more. Available for Windows, Mac and Linux!



IoT Portfolio  
[www.silabs.com/IoT](http://www.silabs.com/IoT)



SW/HW  
[www.silabs.com/simplicity](http://www.silabs.com/simplicity)



Quality  
[www.silabs.com/quality](http://www.silabs.com/quality)



Support and Community  
[community.silabs.com](http://community.silabs.com)

### Disclaimer

Silicon Laboratories intends to provide customers with the latest, accurate, and in-depth documentation of all peripherals and modules available for system and software implementers using or intending to use the Silicon Laboratories products. Characterization data, available modules and peripherals, memory sizes and memory addresses refer to each specific device, and "Typical" parameters provided can and do vary in different applications. Application examples described herein are for illustrative purposes only. Silicon Laboratories reserves the right to make changes without further notice and limitation to product information, specifications, and descriptions herein, and does not give warranties as to the accuracy or completeness of the included information. Silicon Laboratories shall have no liability for the consequences of use of the information supplied herein. This document does not imply or express copyright licenses granted hereunder to design or fabricate any integrated circuits. The products are not designed or authorized to be used within any Life Support System without the specific written consent of Silicon Laboratories. A "Life Support System" is any product or system intended to support or sustain life and/or health, which, if it fails, can be reasonably expected to result in significant personal injury or death. Silicon Laboratories products are not designed or authorized for military applications. Silicon Laboratories products shall under no circumstances be used in weapons of mass destruction including (but not limited to) nuclear, biological or chemical weapons, or missiles capable of delivering such weapons.

### Trademark Information

Silicon Laboratories Inc.®, Silicon Laboratories®, Silicon Labs®, SiLabs® and the Silicon Labs logo®, Bluegiga®, Bluegiga Logo®, Clockbuilder®, CMEMS®, DSPLL®, EFM®, EFM32®, EFR®, Ember®, Energy Micro, Energy Micro logo and combinations thereof, "the world's most energy friendly microcontrollers", Ember®, EZLink®, EZRadio®, EZRadioPRO®, Gecko®, ISOModem®, Precision32®, ProSLIC®, Simplicity Studio®, SIPHY®, Telegesis, the Telegesis Logo®, USBXpress® and others are trademarks or registered trademarks of Silicon Laboratories Inc. ARM, CORTEX, Cortex-M3 and THUMB are trademarks or registered trademarks of ARM Holdings. Keil is a registered trademark of ARM Limited. All other products or brand names mentioned herein are trademarks of their respective holders.



**SILICON LABS**

Silicon Laboratories Inc.  
400 West Cesar Chavez  
Austin, TX 78701  
USA

<http://www.silabs.com>