

USB オーディオ-I2S デジタル・オーディオ・ブリッジ CP2615 データシート

CP2615 デバイスは、USB ベースのオーディオ・アプリケーションの迅速な開発を可能にする目的で設計されています。

CP2615 は、コード開発なしで USB から I2S へのオーディオ・データ転送プロセスを簡素化します。これにより、USB スピーカー、USB ヘッドフォン、USB オルゴール、並びに VoIP システムなどの USB オーディオ・アクセサリの製品化までの時間を短縮することができます。CP2615 には、USB 2.0 フルスピード機能コントローラ、USB トランシーバ、発振器、I2S (オーディオ) インターフェイス、I2C (コントロール) インターフェイス、および UART インターフェイスが含まれています。コンパクトな 5 x 5 mm の QFN-32 パッケージで、スペースに制約のあるポータブル・オーディオ・アプリケーションに最適です。

CP2615 デバイスは、以下を含む広範な USB オーディオ・アプリケーションに最適です。

- ・ USB スピーカー
- ・ MP3 アクセサリ
- ・ ナビゲーション・システム
- ・ USB ヘッドホン/ヘッドセット
- ・ POS 端末
- ・ オルゴール

主な機能

- ・ USB オーディオ・クラス 1.0
- ・ ボリュームおよびミュート同期用 USB HID コンシューマ制御に対応
- ・ USB-UART ブリッジ機能を搭載
- ・ 48 kHz、16 ビット/24 ビット・ステレオ・デジタル・オーディオをサポート
- ・ 統合された USB トランシーバ、外部抵抗不要
- ・ 統合されたクロック、外部水晶不要
- ・ オンチップ電圧レギュレータ：3.45 V 出力
- ・ セルフパワーまたはバスパワー
- ・ ファームウェア開発不要

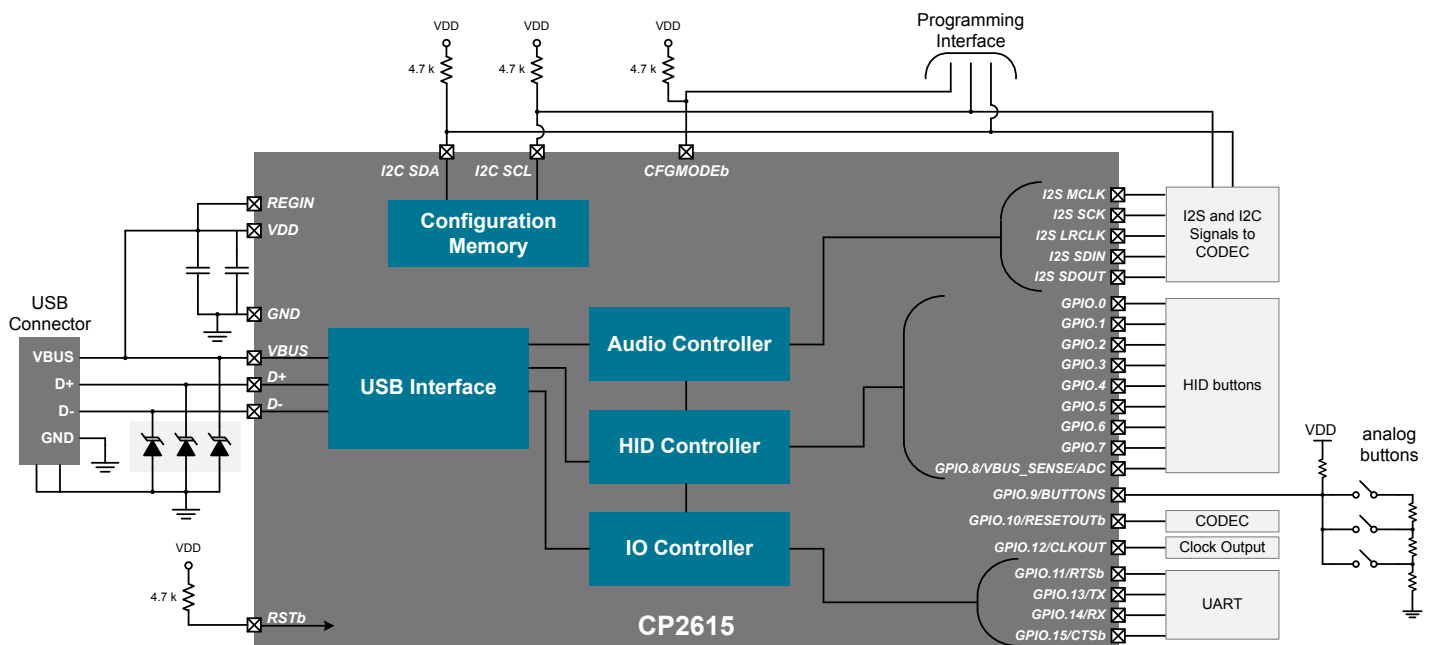

第 1 章 機能リストと注文情報



図 1.1. CP2615 部品番号

CP2615 デバイスには以下の特徴があります。

- ・ シングルチップ USB オーディオ-I²S デジタル・オーディオ・ブリッジ
 - ・ 統合された USB トランシーバ、外部抵抗不要
 - ・ 統合されたクロック、外部水晶不要
 - ・ オンチップ電圧レギュレータ：3.3 V 出力
 - ・ 統合された I²C で DAC/コーデックと通信
- ・ デジタル・オーディオ
 - ・ オーディオ・デバイス・リリース 1.0 の USB デバイス・クラス定義に準拠
 - ・ Windows/Android でネイティブにサポート（カスタム・ドライバ不要）
 - ・ Android USB ホスト・モード・オーディオ
 - ・ 44.1 kHz および 48 kHz のサンプリング・レート
 - ・ 同期または非同期エンドポイント
 - ・ 16 ビット・サンプル使用時の入力および出力同時オーディオ・ストリーム
 - ・ 24 ビット・サンプル使用時の入力または出力方向オーディオ・ストリーム
- ・ USB 周辺装置機能コントローラ
 - ・ USB 仕様 2.0 準拠、フルスピード（12Mbps）
 - ・ USB サスペンド・ステートは、サスペンド・ピン経路でサポート
- ・ USB HID コンシューマ制御
 - ・ ボリュームおよびミュート同期用 USB HID コンシューマ制御に対応
- ・ 電力
 - ・ セルフパワーまたはバスパワー・モードに対応
- ・ その他の機能
 - ・ USB アクティブ・モードとアイドル・モードの両方において低電力で動作するように最適化されているため、デバイス電力供給アクセサリの開発が簡素化される
 - ・ 高度に統合された SoC によって外部部品表（BOM）コストと PCB 設置面積を削減
 - ・ 非水晶 USB の動作により、外部水晶が不要
 - ・ 内蔵のフラッシュ・メモリにデバイスのカスタマイズ・オプションが格納されるため、外部 EEPROM またはフラッシュ・ストレージが不要
 - ・ CP2614 MFi アクセサリ・デジタル・オーディオ・ブリッジとピン互換がある

2. Electrical Specifications

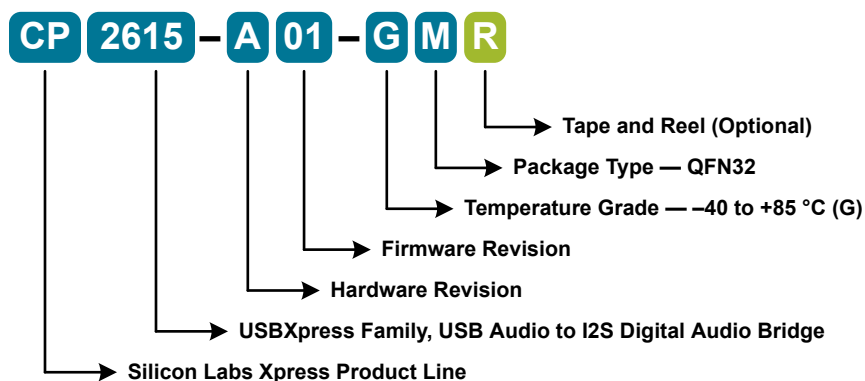
2.1 Electrical Characteristics

2.1.1 Recommended Operating Conditions

Table 2.1. Global DC Electrical Characteristics ¹

Parameter	Symbol	Test Condition	Min	Typ	Max	Units
Digital Supply Voltage	V_{DD}		2.7	—	3.6	V
Supply Current – Active Mode		Sample rates: 44.1 kHz or 48 kHz Modes: • Play and Record (16-bit) • Play-only (24-bit or 16-bit) • Record-only (24-bit or 16-bit)	—	20.2	—	mA
Supply Current – Idle Mode		Audio Play and Record not active	—	7.2	—	mA
Supply Current - Suspend Mode			—	300	—	μ A
Specified Operating Temperature Range			–40	—	+85	$^{\circ}$ C
Note: 1. V_{DD} = 2.7 to 3.6 V, –40 to +85 $^{\circ}$ C unless otherwise specified.						

2.1.2 I²S, I²C, GPIO and Alternate Function Pins

Table 2.2. I²S, I²C, GPIO and Alternate Function Pins DC Electrical Characteristics ¹

Parameter	Symbol	Test Condition	Min	Typ	Max	Units
Output High Voltage	V_{OH}	$I_{OH} = -10 \mu$ A, Port I/O push-pull	$V_{DD} - 0.1$	—	—	V
		$I_{OH} = -3$ mA, Port I/O push-pull	$V_{DD} - 0.7$	—	—	
		$I_{OH} = -10$ mA, Port I/O push-pull	—	$V_{DD} - 0.8$	—	
Output Low Voltage	V_{OL}	$I_{OL} = 10 \mu$ A	—	—	0.1	V
		$I_{OL} = 8.5$ mA	—	—	0.6	
		$I_{OL} = 25$ mA	—	1.0	—	
Input High Voltage	V_{IH}		2.0	—	—	V
Input Low Voltage	V_{IL}		—	—	0.8	V
Input Leakage Current		Weak Pull-Up Off	—	—	± 1	μ A
		Weak Pull-Up On, $V_{IN} = 0$ V	—	15	50	
Note: 1. V_{DD} = 2.7 to 3.6 V, –40 to +85 $^{\circ}$ C unless otherwise specified.						

2.1.3 Reset

Table 2.3. Reset Electrical Characteristics ¹

Parameter	Symbol	Test Condition	Min	Typ	Max	Units
RSTb Input High Voltage			$0.7 \times V_{DD}$	—	—	V
RSTb Input Low Voltage			—	—	$0.3 \times V_{DD}$	V
Minimum RSTb Low Time to Generate a System Reset			15	—	—	μs
RSTb Input Pullup Current		RSTb = 0.0 V	—	15	40	μA
V_{DD} Ramp Time for Power On			—	—	1	ms
I ² C Slave Mode delay after reset		RSTb high to first I ² C transaction	100	—	—	ms

Note:
1. –40 to +85 °C unless otherwise specified.

2.1.4 Voltage Regulator

Table 2.4. Voltage Regulator Electrical Specifications ¹

Parameter	Symbol	Test Condition	Min	Typ	Max	Units
Input Voltage Range			2.7	—	5.25	V
Output Voltage		Output Current = 1 to 100 mA	3.0	3.3	3.6	V

Note:
1. –40 to +85 °C unless otherwise specified.

2.1.5 GPIO Output

Table 2.5. GPIO Output Specifications ¹

Parameter	Symbol	Test Condition	Min	Typ	Max	Units
GPIO.12/CLKOUT frequency	f_{OUT}^2		$f_{OUT} \times 0.985$	f_{OUT}	$f_{OUT} \times 1.015$	Hz

Note:
1. –40 to +85 °C unless otherwise specified.
2. f_{OUT} is the CLKOUT frequency programmed by configuration.

2.1.6 I²S Digital Audio InterfaceTable 2.6. I²S Digital Audio Interface Specifications ¹

Parameter	Symbol	Test Condition	Min	Typ	Max	Units
Resolution (output)			—	16	24	bits
Resolution (input)			—	16	24	bits
I2S_MCLK frequency			—	12	—	MHz
I2S_LRCLK frequency		Sample Rate = 48 kHz	—	48.0	—	kHz
		Sample Rate = 44.1 kHz	—	44.118	—	kHz
I2S_SCLK frequency			—	3.429	—	MHz
I2S_MCLK/I2S_LRCLK jitter		Asynchronous endpoint	—	140	—	ps RMS
Note: 1. $V_{DD} = 2.7$ to 3.6 V, -40 to $+85$ °C unless otherwise specified.						

2.1.7 I2C

Table 2.7. I2C Specifications ¹

Parameter	Symbol	Test Condition	Min	Typ	Max	Units
I2C_SCL frequency			—	100	—	kHz
Time to execute erase command		I ² C slave mode	—	65	100	ms
Time to execute write command		I ² C slave mode, 16-byte block	—	0.8	1.2	ms
Note: 1. $V_{DD} = 2.7$ to 3.6 V, -40 to $+85$ °C unless otherwise specified.						

2.1.8 Analog Output/Input

Table 2.8. Analog Output/Input Characteristics

Parameter	Symbol	Test Condition ¹	Min	Typ	Max	Units
Analog Output						
THD + Noise		Playback resolution: 24 bits Asynchronous endpoint	—	-84	—	dB
		Playback resolution: 16 bits Asynchronous endpoint	—	-83	—	dB
Analog Input						
THD + Noise		Playback resolution: 24 bits Asynchronous endpoint	—	-75	—	dB
		Playback resolution: 16 bits Asynchronous endpoint	—	-74	—	dB
Note: 1. Common test conditions: <ul style="list-style-type: none"> • Sample rate — 48 kHz • Analog Output test signal — WAV file, 1 kHz, 0 dBFS • Analog Output measurement point — HEADPHONE jack (CP2615 Evaluation Board) • Analog Input test signal — 1 kHz, 1.0 VRMS • Analog Input stimulus point — LINE IN jack (CP2615 Evaluation Board) • Measurement bandwidth — 20 Hz – 20 kHz 						

2.2 Absolute Maximum Ratings

Stresses above those listed in [2.1.1 Recommended Operating Conditions](#) may cause permanent damage to the device. This is a stress rating only and functional operation of the devices at those or any other conditions above those indicated in the operation listings of this specification is not implied. Exposure to maximum rating conditions for extended periods may affect device reliability. For more information on the available quality and reliability data, see the Quality and Reliability Monitor Report at <http://www.silabs.com/support/quality/pages/default.aspx>.

Table 2.9. Absolute Maximum Ratings

Parameter	Symbol	Test Condition	Min	Max	Units
Ambient Temperature Under Bias			-55	125	C
Storage Temperature			-65	150	C
Voltage on RSTb, GPIO, I ² S, I ² C, or VBUS Pins with respect to GND		$V_{DD} \geq 2.2 \text{ V}$	-0.3	5.8	V
		$V_{DD} < 2.2 \text{ V}$	-0.3	$V_{DD} + 3.6$	
Voltage on VBUS with respect to GND		$V_{DD} \geq 3.0 \text{ V}$	-0.3	5.8	V
		V_{DD} not powered	-0.3	$V_{DD} + 3.6$	
Voltage on V_{DD} with respect to GND			-0.3	4.2	V
Maximum Total Current through V_{DD} or GND			—	500	mA
Maximum Output Current Sunk by RSTb or any I/O pin			—	100	mA

3. Functional Description

3.1 Audio Interfaces

3.1.1 Interface Signals

The CP2615 provides a Master Clock output and bidirectional I²S Master-mode interface for connection to an external converter. (For brevity, the term “converter” is used to represent a codec, DAC, or ADC.) The figure below shows the signals that comprise the audio interface.

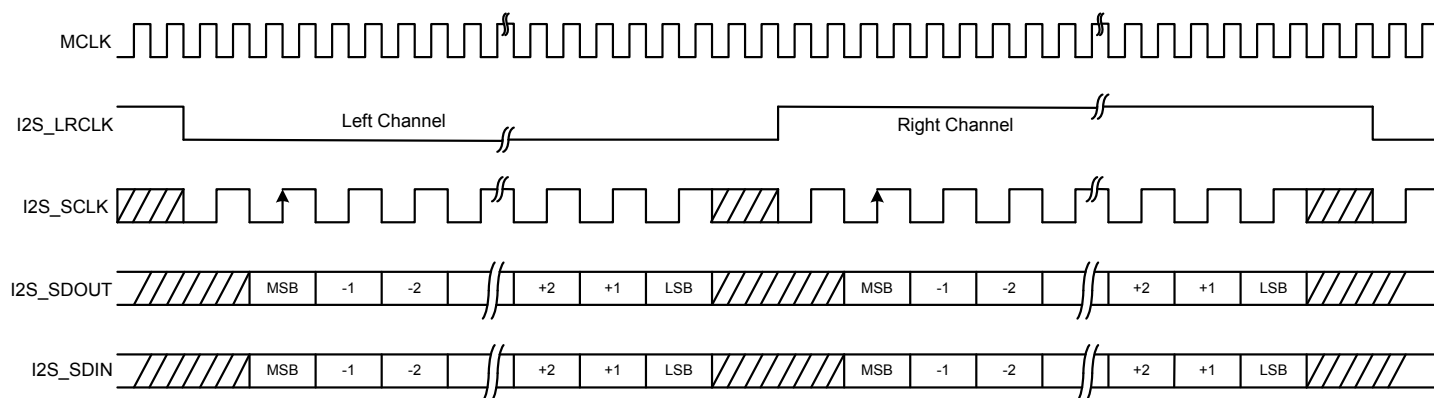

Figure 3.1. Audio Interface Signals

I2S_MCLK (output): The 12 MHz Master Clock output is typically used by oversampling audio converters to drive their internal analog-to-digital or digital-to-analog conversions.

I2S_LRCLK (output): The Left-Right Clock signal indicates which channel is currently being transferred on the interface. The I²S specification refers to this signal as WS (word select). The frequency of the I2S_LRCLK signal corresponds to the audio sample rate. The I2S_LRCLK and I2S_MCLK signals are derived from the same source, and I2S_LRCLK is an integer submultiple of I2S_MCLK. (Both of these attributes are typically required for proper codec operation.)

I2S_SCLK (output): The rising edge of Serial Clock indicates valid data on I2S_SDOUT and I2S_SDIN.

I2S_SDOUT (output): Serial Data Output from CP2615, typically connected to external DAC.

I2S_SDIN (input): Serial Data Input to CP2615, typically connected to external ADC.

The CP2615 operates in I²S Master Mode, and the I2S_LRCLK and I2S_SCLK signals are outputs from the CP2615. The external codec must operate in I²S Slave Mode. The I2S_LRCLK and I2S_SCLK signals are inputs for this mode.

3.1.2 Audio Sample Rates

The CP2615 supports audio sample rates of 44.1 kHz and 48 kHz. If both Playback and Record are used simultaneously, they must operate at the same sample rate. [Table 3.1 I2S_MCLK and I2S_LRCLK Supported Sample Rates on page 7](#) describes the relationship of I2S_MCLK and I2S_LRCLK for the supported sample rates:

Table 3.1. I2S_MCLK and I2S_LRCLK Supported Sample Rates

I2S_MCLK Frequency	Nominal Sample Rate	I2S_MCLK/I2S_LRCLK Ratio	I2S_LRCLK Frequency
12.0 MHz	48 kHz	250	48000 Hz
	44.1 kHz	272	44,117.6 Hz

3.1.3 Audio Sample Resolutions

The CP2615 can be configured to support any one of the following stereo Playback/Record modes:

- Playback and Record: 16-bit resolution
- Playback only: 24-bit or 16-bit resolution
- Record only: 24-bit or 16-bit resolution

3.1.4 Audio Endpoint Synchronizations

USB audio endpoint synchronization is defined in Table 5.12 Synchronization Characteristics of the *Universal Serial Bus Specification Revision 2.0*. The CP2615 supports the synchronous or asynchronous endpoint synchronization methods for all input and output streaming configurations. In synchronous mode, the CP2615 adjusts the frequency of I2S_MCLK and I2S_LRCLK to match the rate at which Start-of-Frame (SOF) packets are received from the USB host. In asynchronous mode, the CP2615 does not adjust the I2S clocks and instead relies on the USB host to provide the synchronization based on implicit feedback from the input endpoint.

3.2 USB Function Controller and Transceiver

The Universal Serial Bus (USB) function controller in the CP2615 is a USB 2.0 compliant full-speed device with integrated transceiver and on-chip matching and pullup resistors. The USB function controller manages all control, audio, HID, and IO interface transfers between the USB host and the CP2615.

3.2.1 Endpoint Usage

The USB endpoints are allocated as follows:

Table 3.2. USB Endpoint Allocations

Endpoint	Function
0	USB control
1	HID interface
2	Serial I/O interface
3	Audio streaming (configurable)

3.2.1.1 USB Control Endpoint

The USB control endpoint is used for enumeration and normal USB control functions.

3.2.1.2 HID Interface Endpoint

The HID endpoint is an interrupt IN endpoint that is used to report Consumer Control (i.e. volume up, volume down, etc.) button presses.

3.2.1.3 Serial I/O Interface Endpoint

The Serial I/O endpoint is a bidirectional bulk interface that transfers either serial pass-through data with the CP2615 UART or I/O Protocol messages. A host application can use this interface to communicate with external devices or to interact with CP2615 general purpose I/O.

3.2.1.4 Audio Streaming Endpoint

This is an isochronous unidirectional or bi-directional audio streaming endpoint that carries USB digital audio data between the USB host and the CP2615. The audio streaming interface has several possible configurations.

3.2.2 USB Suspend

The USB Suspend and Resume modes are supported for power management of the CP2615 device. There are two optional Suspend output signals that can be used to control power switching to external circuitry. These are SUSPEND (active high) and SUSPENDb (active low). The CP2615 will enter Suspend mode when Suspend signaling is detected on the bus. On entering Suspend mode, the configured Suspend output signals are asserted. The Suspend signals are also asserted after a CP2615 reset until device configuration during USB enumeration is complete. The SUSPEND signal is logic high when the device is in the Suspend state, and logic low when the device is in the normal mode. The SUSPENDb signal has the opposite logic value of SUSPEND.

The CP2615 exits Suspend mode when any of the following occur: Resume signaling is detected or generated, a USB Reset signal is detected, or a device reset occurs. SUSPEND and SUSPENDb are weakly pulled to VIO in a high impedance state during a CP2615 reset. If this behavior is undesirable, a strong pulldown (10 Ω) can be used to ensure SUSPEND remains low during reset.

The output mode (push-pull or open drain) of the optional suspend output signals is controlled by the CP2615 configuration. Refer to the Configuration section for more details.

3.3 Asynchronous Serial Data Bus (UART) Interface

The CP2615 provides an asynchronous serial (UART) interface whose function is determined by the device configuration. When enabled, the UART interface provides a full duplex communication channel with a USB host application.

The UART interface consists of the GPIO.13/TX (transmit) and GPIO.14/RX (receive) data signals as well as the GPIO.11/RTS (ready to send) and GPIO.15/CTS (clear to send) flow control signals. These signals are described in [3.4.1.1 GPIO.15, 11—UART Flow-Control Pins \(RTS/CTS\)](#). Both the TX and RX signals must be configured to enable the UART interface. The use of RTS and CTS is optional depending on the use-case and baud rate.

The UART interface uses a fixed line configuration of 8 data bits, 1 stop bit and no parity (i.e., 8N1). Five common baud rates (115200, 57600, 38400, 19200 and 9600) are supported depending on the CP2615 functional configuration. Refer to the following sections for more information on the supported baud rates.

3.3.1 Serial Pass-Through Mode

When the CP2615 is configured for serial pass-through, the UART interface is used exclusively to provide a bi-directional data stream with a USB host application. The format and content of this communication stream is determined by the application and the CP2615 does not examine or interpret the data.

To ensure audio quality is not compromised, serial pass-through only supports low throughput communication. The table below summarizes the supported UART configurations for this mode. Communication over the serial pass-through may become unreliable if any other configuration is used.

Table 3.3. Supported Serial Pass-Through Configurations

Configuration	Baud Rate	GPIO.11 / RTS	GPIO.15 / CTS
Any audio mode	9600	Optional	Optional
No audio mode	All supported rates	Required above 19200	Optional

3.4 GPIO

The CP2615 supports sixteen user-configurable GPIO pins. Each of these GPIO pins can be used as an input, open-drain output or push-pull output. GPIO pins are observed and controlled through the CP2615 I/O Protocol (IOP) which is accessed through the Serial I/O interface. Alternately, each GPIO pin can be assigned to a predefined alternate function that is directly controlled by the CP2615. The available alternate functions are described in the following sections.

The function, mode and initial state of the sixteen GPIO pins is determined by the device configuration. More information regarding the configuration and usage of these pins is available in *AN1044: CP2615 Customization User Guide*.

3.4.1 Fixed Alternate Pin Functions

GPIO.15-8 pins have fixed alternate functions that are listed in the table below. Each pin may be individually configured as either a GPIO or its assigned alternate function. Alternate function pins are controlled directly by the CP2615, but their state can be read by the IOP protocol. Alternate function outputs can be configured as open-drain or push-pull.

Table 3.4. GPIO.15-8 Alternate Functions

Pin	Alternate Function
GPIO.15 / CTS	UART CTS Flow-control Input
GPIO.14 / RX	UART Receive Data Input
GPIO.13 / TX	UART Transmit Data Output
GPIO.12 / CLKOUT	Clock Output
GPIO.11 / RTS	UART RTS Flow-control Output
GPIO.10 / RESETOUTb	Codec Reset Output
GPIO.9 / BUTTONS	Pushbutton Ladder Input
GPIO.8 / ADC	ADC Analog Input

3.4.1.1 GPIO.15, 11—UART Flow-Control Pins (RTS/CTS)

The UART flow-control pins are used to prevent data loss by regulating the flow of UART data in either direction. These alternate functions are available when the CP2615 has been configured to enable the Serial I/O interface described in [3.3.1 Serial Pass-Through Mode](#). The pins are selected independently, so it is possible to have either or both configured.

GPIO.15/CTS, or Clear To Send, is an active-low input to the CP2615 and is used by an external UART device to signal that its receive buffers are nearly full. The CP2615 will halt transmitting data while CTS is pulled high.

GPIO.11/RTS, or Request To Send, is an active-low output from the CP2615, which indicates that the CP2615 is ready to accept data. The CP2615 will de-assert RTS whenever its internal buffers are nearly full. While RTS is high, the external UART device must stop transmitting to avoid data loss.

3.4.1.2 GPIO.14, 13—UART Data Pins (TX/RX)

The UART data pins should be selected whenever the CP2615 has been configured for serial pass-through. Both pins must be selected, even if only one direction is used.

GPIO.14/RX is the receive data pin for the CP2615 UART. Serial data received on this pin will be sent to the host if serial pass-through has been configured.

GPIO.13/TX is the transmit data pin for the CP2615 UART. Serial data from either the serial pass-through feature is transmitted on this pin.

3.4.1.3 GPIO.12—Programmable Clock Output (CLKOUT)

GPIO.12/CLKOUT is a configurable CMOS clock output. The clock output appears at the pin after the device enters Intermittent High Power Mode. The clock output is removed from the pin when the device enters Low Power Mode or USB Suspend mode.

The output frequency is configurable through the use of a divider. When the divider is set to 0, the output frequency is 93.75 kHz. For divider values between 1 and 255, the output frequency is determined by the formula:

$$\text{CLKOUT}_{\text{freq}} = \frac{48 \text{ MHz}}{2 \times \text{divider}}$$

3.4.1.4 GPIO.10—Codec Reset Output (RESETOUTb)

GPIO.10/RESETOUTb is an active-low output that is typically used to drive the reset pin of the external codec. This pin is asserted (i.e. driven low) when the CP2615 enters Low Power mode, and can be controlled at other times via user-configurable I²C command strings. For more information, see [3.6.1.1 Command Strings for Codec Configuration](#).

3.4.1.5 GPIO.9—Pushbutton Ladder Input (BUTTONS)

The CP2615 can be configured to report common consumer control buttons through the HID interface. When this feature is enabled, GPIO.9/BUTTONS can be used with a simple resistor ladder and up to fourteen pushbuttons to provide media button input to the CP2615. Additionally, HID media buttons can be connected as digital inputs to GPIO.7-0, which is described in [3.4.2.1 HID Media Buttons](#).

To sense button presses, the CP2615 periodically samples the input voltage on GPIO.9/BUTTONS. Once the input remains steady for a complete debounce period, the CP2615 converts the input value into a HID media button as determined by the device configuration. USB HID reports are then sent to the host as the button is pressed and when it is released.

The CP2615 divides the GPIO.9/BUTTONS input into sixteen equal sized ($V_{DD}/16$) slots numbered from 0 to 15. The center of each slot is given by the following equation, where n is the slot number.

$$V_n = \frac{V_{DD}}{32} \times (1 + 2 \times n)$$

Slots 1 through 14 can be assigned to any button listed in [Table 3.6 GPIO.7-0 Selectable Alternate Input Functions on page 13](#), while slots 0 and 15 are reserved for the no button pressed condition. Slots can also be left unassigned, in which case they are ignored.

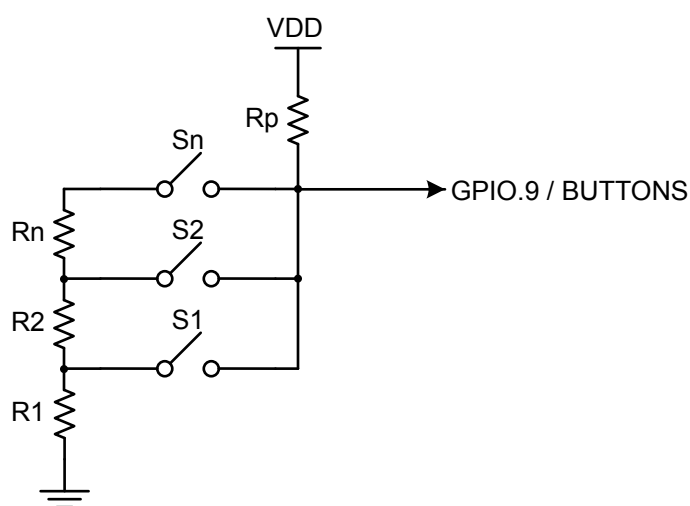

Figure 3.2. Example GPIO.9/BUTTONS Input Circuit

An example circuit for driving GPIO.9/BUTTONS is shown in the figure above. The circuit in the figure only shows three switches, but can easily be expanded by adding additional resistors and switches. While any switch is pressed a simple voltage divider of V_{DD} is formed and the voltage at GPIO.9/BUTTONS is easily calculated with the following equation.

$$V_{\text{buttons}} = V_{DD} \times \left(\frac{\sum_1^n R_i}{R_p + \sum_1^n R_i} \right)$$

The values of the resistor ladder should be selected so that the divider formed by each switch produces a voltage that is near the center of the switch's assigned slot. A set of resistor values for a fourteen button ladder are provided in the table, [Table 3.5 Resistor Values for Example GPIO.9/BUTTONS Circuit on page 12](#). To guarantee proper operation, 1% tolerance resistors should be used.

The example circuit in the figure above has some features worth noting. First, with no button pressed R_p holds GPIO.9/BUTTONS in slot 15 and the resistor ladder draws no current. Also, when multiple switches are pressed, the lowest numbered switch is recognized while the others are ignored. This is because the lowest switch effectively shorts the resistor ladder of the higher switches.

Table 3.5. Resistor Values for Example GPIO.9/BUTTONS Circuit

Resistor	Value (k Ω)	Resistor	Value (k Ω)
Rp	100	—	—
R1	10.0	R8	24.9
R2	8.25	R9	33.2
R3	10.0	R10	44.2
R4	10.0	R11	64.9
R5	15.0	R12	100
R6	15.0	R13	182
R7	20.0	R14	432

3.4.1.6 GPIO.8—ADC Analog Input (ADC)

The ADC Analog Input alternate function provides a low-rate analog measurement channel that is reported through the I/O Protocol. The analog value can be polled or automatically reported whenever the value change exceeds a programmable threshold. The CP2615 samples GPIO.8/ADC at approximately 50 samples per second and provides 10-bit resolution referenced to V_{DD} . This pin can be used to track a slow moving sensor value such as temperature.

3.4.2 Selectable Alternate Pin Functions

GPIO.7-0 pins have selectable alternate functions that can be mapped to any pin. The selectable alternate input functions and the selectable alternate output functions are listed in the tables below. These predefined functions can be assigned to GPIO.7-0 in any order and combination. Additionally, all output functions can be assigned to more than one pin if desired, and can be configured as open-drain or push-pull. Alternate function pins are controlled directly by the CP2615, but their state can be read by the IOP protocol.

Table 3.6. GPIO.7-0 Selectable Alternate Input Functions

Alternate Input Name	Function
PLAY_PAUSE	HID Media Button – Play/Pause
FFWD	HID Media Button – Scan Next Track
REW	HID Media Button – Scan Previous Track
MUTE	HID Media Button – Playback Mute
VOL+	HID Media Button – Volume Increment
VOL-	HID Media Button – Volume Decrement
PLAY	HID Media Button – Play
STOP	HID Media Button – Stop
RECMUTE	Record Mute Toggle Button Input

Table 3.7. GPIO.7-0 Selectable Alternate Output Functions

Alternate Output Name	Function
SUSPEND	Suspend Mode (active high)
SUSPENDb	Suspend Mode (active low)
LOWPWR	Low Power Mode (active high)
LOWPWRb	Low Power Mode (active low)
RMUTE	Audio Record is Muted (active high)
RMUTEb	Audio Record is Muted (active low)
PBMUTE	Audio Playback is Muted (active high)
PBMUTEb	Audio Playback is Muted (active low)

3.4.2.1 HID Media Buttons

The CP2615 can be configured to report common consumer control buttons through the HID interface. These active low inputs are debounced by the CP2615 and are used to generate the HID reports on both the leading and trailing edges of a button push. The supported HID usages are indicated in [Table 3.6 GPIO.7-0 Selectable Alternate Input Functions on page 13](#). These inputs should be connected to momentary pushbuttons through an external pull-up resistor. Note that buttons can also be connected to the CP2615 using GPIO.9/BUTTONS as described in [3.4.1.5 GPIO.9—Pushbutton Ladder Input \(BUTTONS\)](#).

3.4.2.2 Record Mute Toggle Button

This active low input is debounced by the CP2615 and is used to toggle the internal audio record mute state. The CP2615 record mute state is toggled on a low-to-high transition. This input should be connected to a momentary pushbutton through an external pull-up resistor.

3.4.2.3 SUSPEND, SUSPENDb

These complimentary outputs are asserted while the CP2615 is in USB Suspend mode. The CP2615 enters USB Suspend mode when it is powered and USB is disconnected or USB activity is stopped by the connected USB host. This situation occurs if the CP2615 accessory is self-powered (such as with a battery) and a connected USB host goes into standby mode (powers down) or USB is disconnected. If the accessory is device powered, then USB Suspend mode will not be used. The CP2615 enters a very low power state while in USB Suspend mode, and the SUSPEND output signal(s) can be used to switch power to other circuitry in the accessory.

3.4.2.4 LOWPWR, LOWPWRb

These complimentary outputs are asserted whenever the CP2615 is in low power mode. The CP2615 enters low power mode when both the audio and serial I/O interfaces are idle. The LOWPWR output signal(s) can be used to switch power to other circuitry in the accessory in order to save power.

3.4.2.5 RMUTE, RMUTEb

The CP2615 asserts these complimentary outputs whenever it is muting the audio record channel. These signals reflect the state of the CP2615 audio record mute and can be used to drive a visual indicator for user feedback or drive the mute control of a microphone pre-amp.

3.4.2.6 PBMUTE, PBMUTEb

The CP2615 asserts these complimentary outputs whenever the host has commanded the CP2615 to mute the audio playback channel. These signals can be used to drive mute controls in the playback circuitry or to provide user feedback by driving a visual indicator.

3.4.3 IO Protocol

The CP2615 implements a simple messaging protocol that provides USB host applications a means for observing and controlling various I/O features. This custom protocol is named the IO Protocol (IOP) and is implemented over the Serial I/O USB interface.

The IO Protocol is a stateless, message based protocol that allows a USB host application to do the following:

- Query device identification information.
- Query GPIO configuration.
- Observe and control the GPIO.15-0 pins.
- Observe the analog pin GPIO.8/ADC.
- Receive autonomous notifications of GPIO/ADC changes.
- Perform small transfers on the I2C bus.
- Query error status of the UART.

Any pin configured as a GPIO output can be controlled by the IO Protocol. This allows a USB host application to control visual indicators or other hardware connected to the CP2615.

The IO Protocol supports two methods for observing GPIO.15-0 digital values and GPIO.8/ADC analog values. The USB host application can poll the CP2615 by sending an appropriate IOP message and receiving the response. Alternatively, the USB host application can request that IOP notification messages be sent automatically whenever specific GPIO pins change value. All GPIO pins, including those assigned to alternate functions, may be monitored over the IOP.

3.5 Configuration

The CP2615 has an extensive set of configurable features and attributes. To streamline the product development process, the CP2615 Evaluation Kit provides tools that enable users to easily customize and program the CP2615 configuration parameters to meet the requirements of their system.

In the production environment, the CP2615 configuration can be programmed in-situ using an industry-standard I²C EEPROM Programmer or equivalent. Customers can also order devices that are pre-programmed with their customized configuration.

Some of the configuration options of the CP2615 do not have a fixed length. For example, the manufacturer name and product name strings do not have a fixed length. Also, the codec configuration data can be variable length. While the CP2615 does not enforce any fixed length on these individual fields, the total configuration size can be a maximum of 2800 bytes. The baseline configuration length with no codec configuration and minimal identification strings is about 575 bytes. The CP2615 customization tool will show you the size of the configuration.

3.5.1 Configuration Parameters

The CP2615 configuration parameters can be grouped as follows:

- Device IDs and Strings
- Power Options
- Audio Options
- GPIO and Alternate Functions

The following sections provide an overview of each of these categories. For more information on CP2615 configuration parameters, refer to *AN1044: CP2615 Customization User Guide*.

3.5.1.1 Device IDs and strings

The following IDs and strings are configurable:

- USB Vendor and Product IDs
- USB Manufacturer, Product, and Serial Number strings

3.5.1.2 Power Options

The following power options are configurable:

- Power Mode (Bus-Powered or Self-Powered)
- Maximum Power Consumption

3.5.1.3 HID Consumer Control Buttons

- HID Consumer Control Buttons
 - Play
 - Stop
 - Scan Next Track (Transport Right)
 - Scan Previous Track (Transport Left)
 - Play/Pause
 - Mute
 - Volume Increment (Louder)
 - Volume Decrement (Softer)

3.5.1.4 Audio Options

The following audio playback and record options are selectable:

- No playback or record
- Playback only, 16-bit resolution
- Playback only, 24-bit resolution
- Record only, 16-bit resolution
- Record only, 24-bit resolution
- Playback and record, 16-bit resolution
- Synchronization mode: synchronous or asynchronous

To facilitate using the CP2615 with various codecs devices, the configuration contains elements for specifying volume and mute behavior, as well as I²C commands for initializing and dynamically configuring the codec.

3.5.1.5 GPIO and Alternate Functions

GPIO pins can be configured to have fixed or selectable functions, as as a general purpose input or output. For more information about fixed alternate pin functions, see [3.4.1 Fixed Alternate Pin Functions](#) and for selectable pin functions see [3.4.2 Selectable Alternate Pin Functions](#).

3.6 I²C Interface

The I²C (inter-integrated-circuit) bus is a defacto standard two-wire digital interface. For detailed information on the I²C standard, see the NXP I²C Bus Specification and User Manual.

The CP2615 operates in Standard Mode at the nominal frequency of 100 kbits/s. The SCL (clock) and SDA (data) lines require external pullup resistors for proper operation. The pullup resistors must be sized to ensure that the SCL/SDA rise times satisfy the requirements of all devices on the I²C bus.

The state of the CFGMODEb input pin when nRST becomes deasserted determines whether the CP2615 operates normally (CFGMODEb = high), or enters Configuration Mode (CFGMODEb = low).

3.6.1 Normal Mode: CP2615 as I²C Master

In normal operation the CP2615 acts as the system I²C Master and can communicate with the following I²C slave devices:

- Codec
- Other external slave device(s)

3.6.1.1 Command Strings for Codec Configuration

The CP2615 configuration contains a number of command strings that are used to initialize and configure the codec. The table below lists the command strings and describes when the strings are applied.

Table 3.8. Command Strings

Command String	Description	Requires Zero Terminator?
Codec Initialization	Actions to be performed when the CP2615 transitions from Low Power mode to High Power mode.	Yes
Codec High To Low	Actions to be performed when the CP2615 transitions from High Power mode to Low Power mode.	Yes
Audio Start	Actions to be performed when audio streaming is starting.	Yes
Audio Stop	Actions to be performed when audio streaming is starting.	Yes
Volume Set Prefix Left/Right	I ² C bytes to be sent prior to the volume setting byte.	No
Volume Set Suffix Left/Right	I ² C bytes to be sent after the volume setting byte.	Yes
Get Mute Prefix	I ² C bytes to be sent prior to reading the byte containing the current mute setting.	Yes
Set Mute Prefix	I ² C bytes to be sent prior to writing the mute setting byte.	No
Set Mute Suffix	I ² C bytes to be sent after writing the mute setting byte.	Yes
Set Sample Rate (44.1 kHz)	Actions to be performed when setting the sample rate to 44.1 kHz.	Yes
Set Sample Rate (48 kHz)	Actions to be performed when setting the sample rate to 48 kHz.	Yes

Each command string consists of a length field followed by one or more subcommands:

- U8: length of command string in bytes, not including the length byte
- U8[]: array of bytes containing one or more subcommands

Each subcommand is composed of:

- U8: ASCII-encoded subcommand token
- U8[]: Arguments required by the subcommand token

Most command strings require a termination byte of value 0x00 to indicate the end of all commands. Refer to the table above to see which command strings require the zero-terminator and which do not.

The command string can be up to 2000 bytes long, including the length byte and the zero-terminator. If the string is longer than 254 bytes, the length byte should be set to 254. The maximum command length is for any one string, but all strings cannot be this long. The total space for the entire configuration is 4608 bytes.

The ASCII-encoded tokens and their associated arguments are:

Table 3.9. ASCII-encoded Tokens and Associated Arguments

Token	Operation	Arguments (Binary)
“W” 0x57	I ² C Write (Write one or more bytes)	U8: Number of bytes to write U8: Slave address U8[]: Bytes to be written
“R” 0x52	I ² C Read (Read one or more bytes)	U8: Number of bytes to read U8: Slave address
“P” 0x50	I ² C Stop (Issue stop condition)	<none>
“C” 0x43	Assert codec reset (RESETOUTb) output	<none>
“c” 0x63	Deassert codec reset (RESETOUTb) output	<none>
“D” 0x44	Delay	U8: Delay in ms U8: Reserved
“B” 0x42	CP2615 reboot	U8: waitForTransactionComplete If zero reboot immediately, else reboot when transaction is complete

3.6.1.2 Example I²C Command Strings

The following examples represent typical I²C command strings. The examples use these conventions:

- Tokens are shown as ASCII characters, e.g. “W”
- Binary data is shown as hex (e.g. 0x01)
- “SLA” represents the left-justified slave address

Write 0x44 to register 0x01: 0x06 ‘W’ 0x03 ‘SLA’ 0x01 0x44 ‘P’.

Read 2 bytes from register 0x01: 0x09 ‘W’ 0x02 ‘SLA’ 0x01 ‘P’ ‘R’ 0x02 ‘SLA’ ‘P’.

3.6.1.3 I²C Pass-Through

The CP2615 IO Protocol allows USB host applications to dynamically invoke I²C write and read operations on arbitrary I²C slave devices. The IO protocol is used as the transport mechanism for data transfer between the USB host and external I²C slave devices. For more information on the IO protocol, see [3.4.3 IO Protocol](#).

3.6.2 Configuration Mode: CP2615 as I²C Slave

The state of the CFGMODEb input pin at the conclusion of the device reset state determines whether the CP2615 operates normally (CFGMODEb = high), or enters Configuration Mode (CFGMODEb = low). In Configuration Mode the CP2615 emulates an I²C flash EEPROM; all other device functionality is disabled. The CP2615 remains in Configuration Mode until it is reset or power-cycled. Refer to the figure below for typical configuration connections.

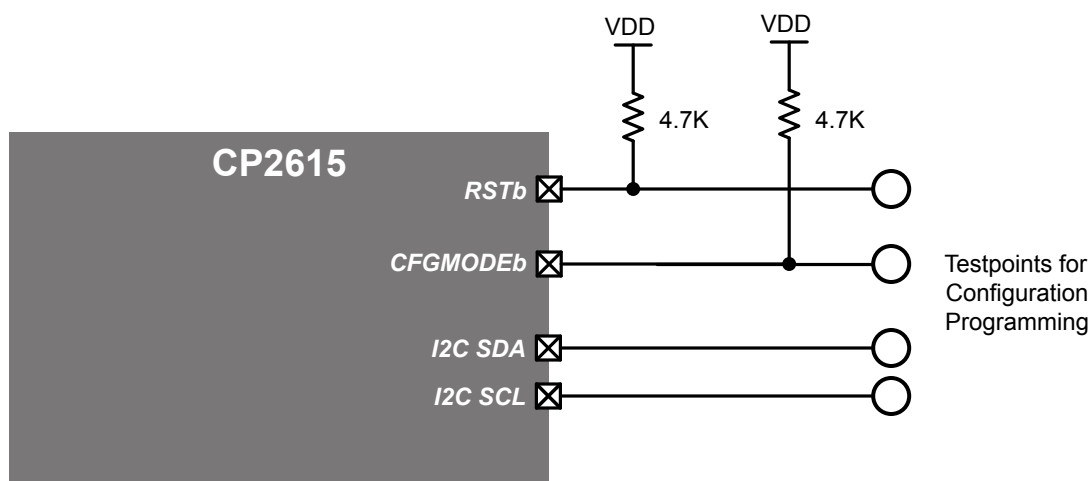

Figure 3.3. Typical I²C Configuration

The following sequence puts the CP2615 into Configuration Mode, after which an external I²C Master can be used to program the CP2615 configuration.

- Drive CFGMODEb and RSTb low (device power can be applied before or after this step)
- Delay at least 15 μ s (the minimum RSTb low time)
- Drive RSTb high
- Delay at least 100 ms

The configuration block consists of 2048 bytes of non-volatile flash memory mapped to address range 0x0000-0x07FF. Two bytes are used in I²C Read and Write transactions to represent the address within the configuration block.

The CP2615 7-bit I2C Slave Address is 0011000. The corresponding 8-bit values for the CP2615 slave address plus the I2C Write/Read bit are 0x30 (Write) and 0x31 (Read).

CP2615 code execution is temporarily halted during the execution of memory erase and write operations. If the external I²C Master cannot tolerate NAKs or does not support retries, it must implement the appropriate delays after issuing I²C erase and write commands.

3.6.2.1 I²C Write Transactions

To prevent inadvertent flash erasure or corruption, each Write transaction must contain the flash keys (0xA5, 0xF1) between the address MSB/LSB and the block of data to be written. Write transactions with invalid flash keys will be ignored. The maximum number of data bytes that can be written per Write transaction is 62 bytes. The format of the Write transaction is:

Table 3.10. Write Transaction Format

Start	0x30 SLA+W	AddrMSB	AddrLSB	0xA5	0xF1	Data[0] ... Data[n]	Stop
-------	---------------	---------	---------	------	------	---------------------	------

3.6.2.2 I²C Read Transactions

The entire configuration block can be read with a single Read transaction (if the external I²C Master is capable) or by using multiple Read transactions of smaller size. The format of the Read transaction is as follows:

Table 3.11. Read Transaction Format

Start	0x30 SLA+W	Address MSB	Address LSB	Stop	Start	0x31 SLA+R	Data[0] ... Data[n]	Stop
-------	---------------	----------------	----------------	------	-------	---------------	------------------------	------

3.6.2.3 Special Operations

To implement special operations, the CP2615 recognizes three addresses outside of the configuration block address range:

Erase the Configuration (write to 0xFFFFC; must include flash keys)

Table 3.12. Erase the Configuration

Start	0x30	0xFF	0xFC	0xA5	0xF1	Stop
-------	------	------	------	------	------	------

Lock the Configuration (write to 0xFFFFD; must include flash keys)

Table 3.13. Lock the Configuration

Start	0x30	0xFF	0xFD	0xA5	0xF1	Stop
-------	------	------	------	------	------	------

Read the Configuration Lock Byte (read from 0xFFFFE)

Table 3.14. Read the Configuration Lock Byte

Start	0x30	0xFF	0xFE	Stop	Start	0x31	ConfigLock- Byte	Stop
-------	------	------	------	------	-------	------	---------------------	------

A Configuration Lock Byte value of 0xFF indicates that the configuration is unlocked and can be erased or written by the external I²C Master. Any other value indicates that the configuration is locked and cannot be written to or erased. The configuration can be locked in either of two ways:

- Programming a configuration whose Configuration Lock Byte is something other than 0xFF.
- Performing an I²C write operation to address 0xFFFFD (with valid slave address and flash keys).

Note:

- This write transaction does not include a data byte; the write transaction itself will clear the Configuration Lock Byte.
- The special operation memory addresses are not real memory addresses.
- Once the configuration is locked, it can never be changed again and cannot be erased.

3.6.2.4 Configuration Programming Example

The following sequence illustrates the actions required of an external I²C Master when programming the CP2615 configuration. The sequence programs the new configuration data in blocks of 16 bytes, which is a typical size used by I²C EEPROM programmers.

- Put the CP2615 into Configuration Mode.
- Read the Configuration Lock Byte to ensure it is 0xFF (i.e. unlocked).
- Erase the configuration.
- Delay while configuration is being erased (see [2.1.7 I²C](#)).
- Read the Configuration Block to ensure all bytes are 0xFF.
- For each block of 16 bytes to be written:
 - Execute Write transaction containing flash keys and 16 bytes of data.
 - Delay while configuration data is being written.
 - Execute 16-byte Read transaction to verify data.
- Lock the configuration. (optional).
- To return the CP2615 to normal operation, reset or power-cycle the device.

3.7 Voltage Regulator and Power

The CP2615 includes an internal voltage regulator that can be configured to operate in one of several modes. This allows it to be powered from an ordinary USB host or be self-powered.

3.7.1 USB Bus-Powered Connection

A typical connection diagram of the device in a USB bus-powered application using the regulator is shown in the figure below. When enabled, the voltage regulator output appears on the VDD pin and can be used to power external devices. See 2.1.4 Voltage Regulator for the voltage regulator electrical characteristics.

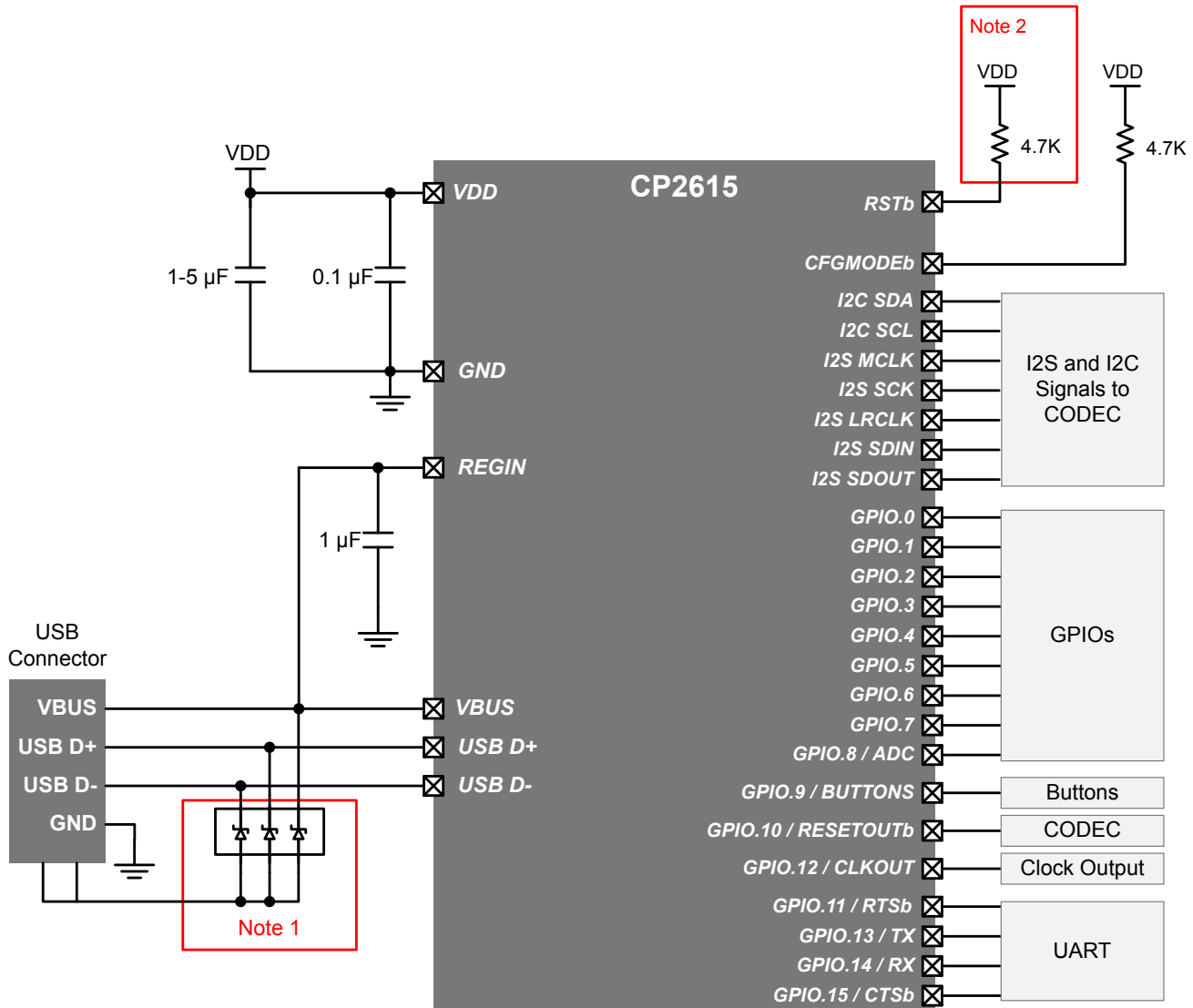

Note 1 : Avalanche transient voltage suppression diodes compatible with Full-speed USB should be added at the connector for ESD protection. Use Littelfuse p/n SP0503BAHT or equivalent.

Note 2 : An external pull-up is not required, but can be added for noise immunity.

Figure 3.4. USB Bus-Powered Configuration

3.7.2 USB 3.3 V Self-Powered Connection

Alternatively, if 3.0 to 3.6 V power source is supplied to the VDD pin, the CP2615 can function as a USB self-powered device with the voltage regulator bypassed. For this configuration, the REGIN input should be tied to VDD to bypass the voltage regulator. A typical connection diagram showing the device in a USB self-powered application with the regulator bypassed is shown in the figure below.

The USB max power and power attributes descriptor must match the device power usage and configuration. See application note AN1044: CP2615 Customization User Guide for information on how to customize USB descriptors for the CP2615.

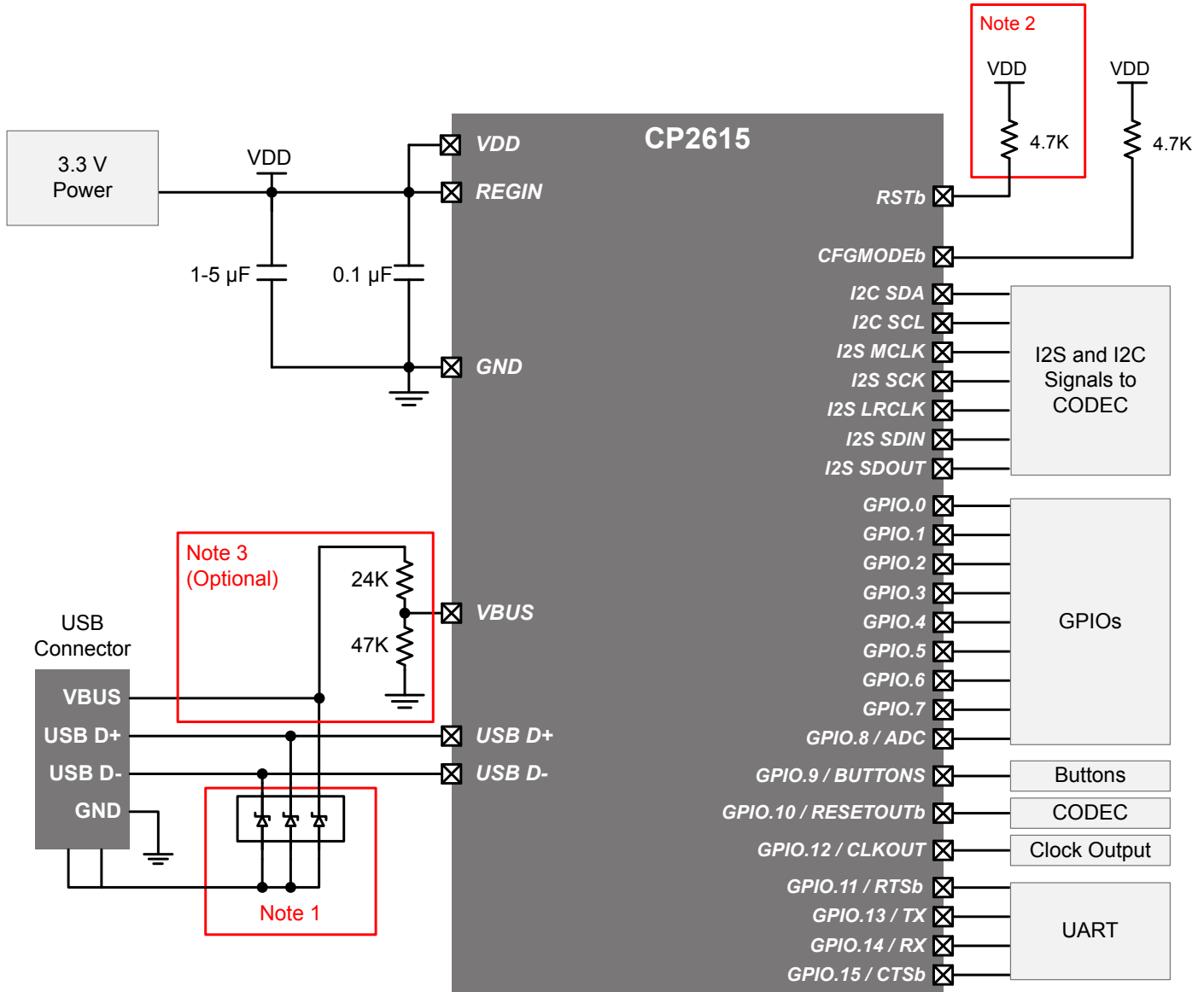

Note 1 : Avalanche transient voltage suppression diodes compatible with Full-speed USB should be added at the connector for ESD protection. Use Littelfuse p/n SP0503BAHT or equivalent.

Note 2 : An external pull-up is not required, but can be added for noise immunity.

Note 3 : For self-powered systems where VDD may be unpowered when VBUS is connected to 5 V, a resistor divider (or functionally-equivalent circuit) on VBUS is required to meet the absolute maximum voltage on VBUS specification in the Electrical Characteristics section.

Figure 3.5. USB Self-Powered Application with Regulator Bypassed

3.7.3 USB 5 V Self-Powered Connection

To use the regulator to provide VDD in a self-powered application, use the configuration shown in the diagram below. If REGIN may be unpowered while VBUS is 5 V, a resistor divider (or functionally equivalent circuit) described in Note 3 of the figure is required to meet the absolute maximum voltage on VBUS specification in 2.2 Absolute Maximum Ratings.

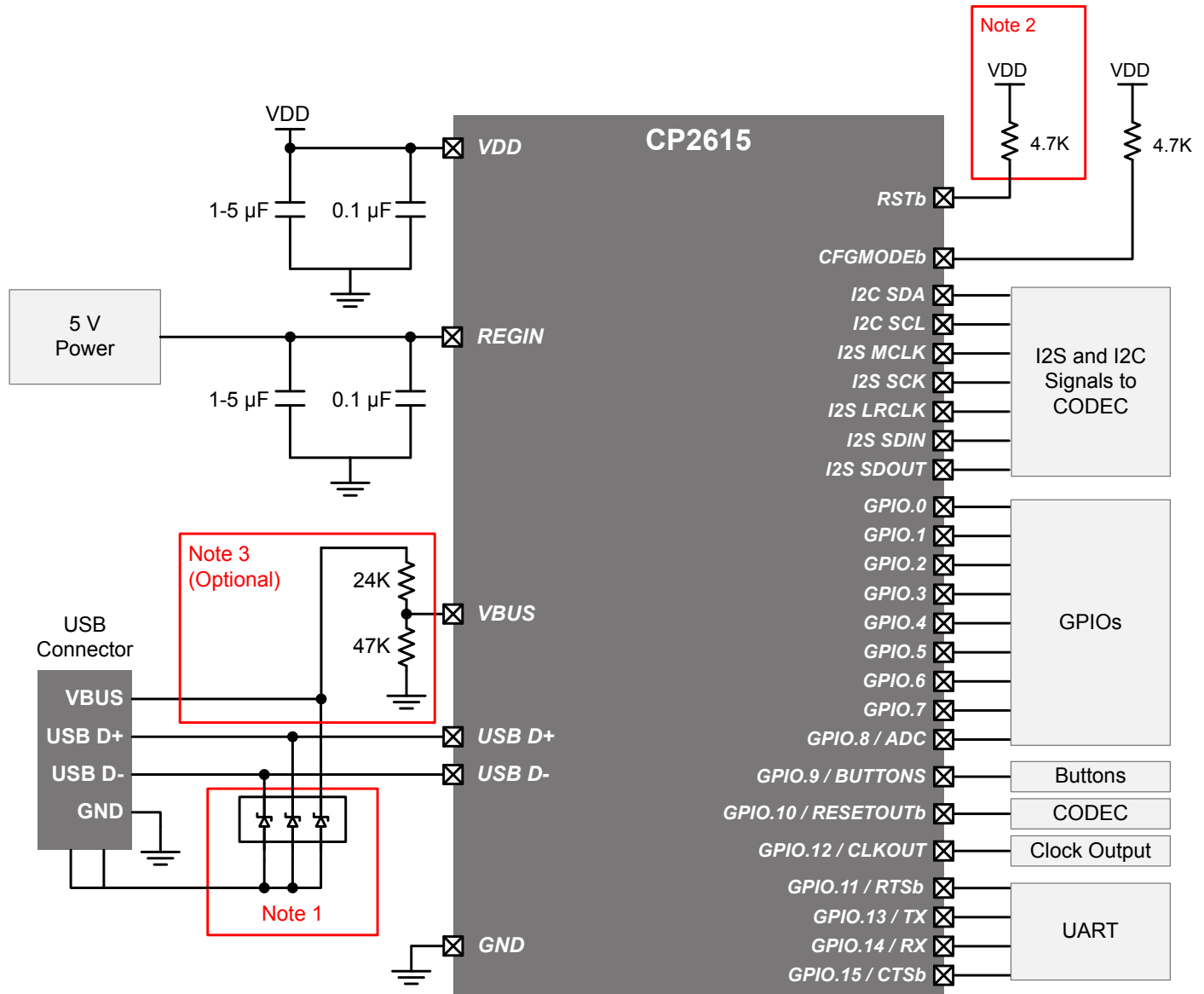

- Note 1 :** Avalanche transient voltage suppression diodes compatible with Full-speed USB should be added at the connector for ESD protection. Use Littelfuse p/n SP0503BAHT or equivalent.
- Note 2 :** An external pull-up is not required, but can be added for noise immunity.
- Note 3 :** For self-powered systems where VDD may be unpowered when VBUS is connected to 5 V, a resistor divider (or functionally-equivalent circuit) on VBUS is required to meet the absolute maximum voltage on VBUS specification in the Electrical Characteristics section.

Figure 3.6. USB 5 V Self-Powered Application with Regulator Used

4. Pin Definitions

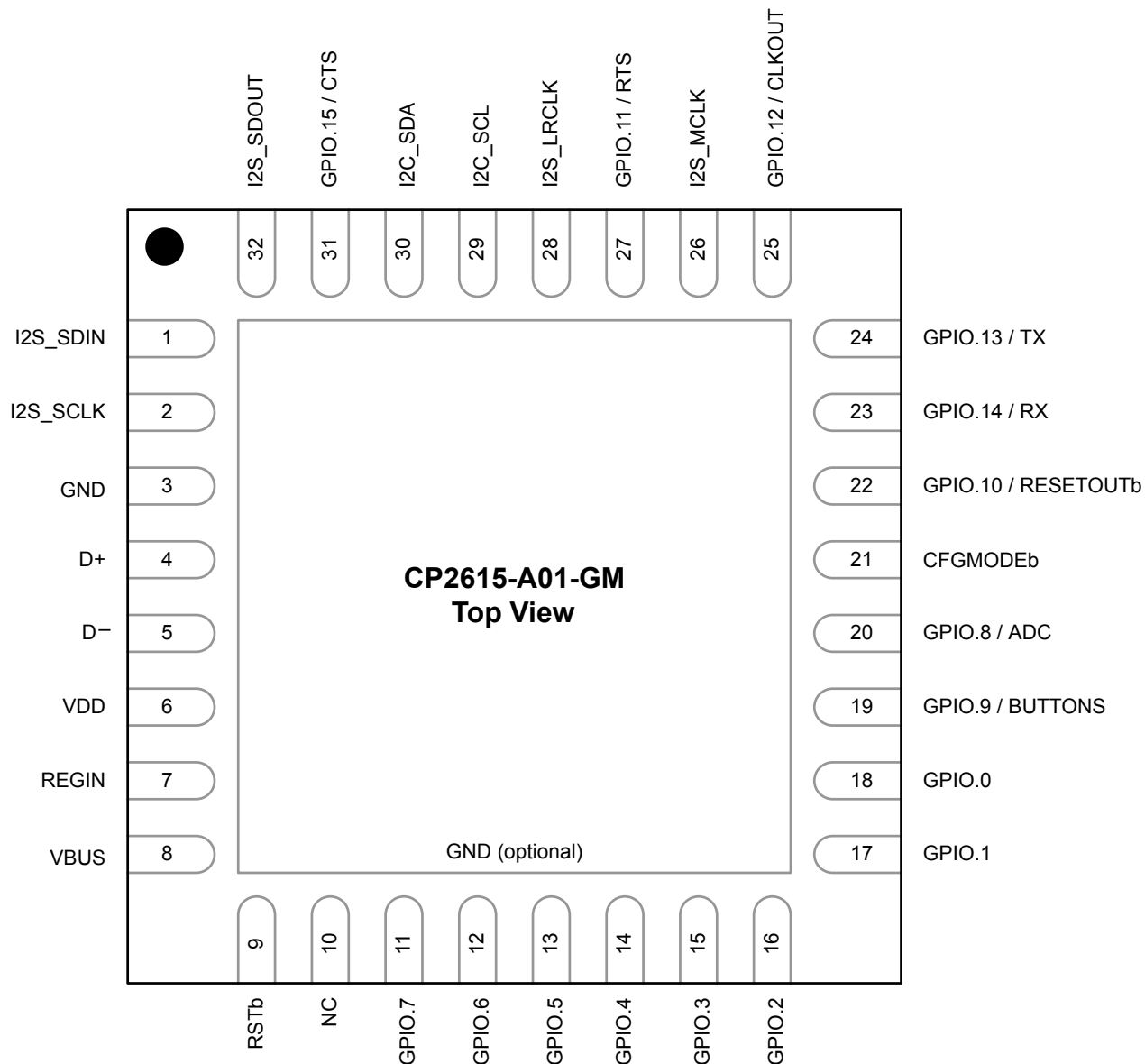

Figure 4.1. CP2615 QFN32 Pinout Diagram (Top View)

Table 4.1. CP2615 Pin Descriptions

Pin #	Name	Function	Description ¹
1	I2S_SDIN	Digital Input ²	I ² S interface: Serial data input
2	I2S_SCLK	Digital Output	I ² S interface: Serial clock output
3	GND		Ground. Must be tied to system ground.
4	D+	Digital Input/Output	USB D+
5	D-	Digital Input/Output	USB D-

Pin #	Name	Function	Description ¹
6	VDD	Power Input	Power supply voltage Input
		Power Output ²	Output of the on-chip voltage regulator
7	REGIN	Power Input	Input to the on-chip voltage regulator
8	VBUS	Digital Input	VBUS Sense Input. This pin should be connected to the Accessory Power signal from a USB host, or to the VBUS signal from a USB host.
9	RSTb	Digital Input/Output ²	Device Reset. Open-drain output of internal POR or VDD monitor. An external source can initiate a system reset by driving this pin low for the time specified in 2.1.3 Reset .
10	NC		This pin should be left unconnected
11	GPIO.7	Digital Input/Output ²	GPIO or selectable alternate function
12	GPIO.6	Digital Input/Output ²	GPIO or selectable alternate function
13	GPIO.5	Digital Input/Output ²	GPIO or selectable alternate function
14	GPIO.4	Digital Input/Output ²	GPIO or selectable alternate function
15	GPIO.3	Digital Input/Output ²	GPIO or selectable alternate function
16	GPIO.2	Digital Input/Output ²	GPIO or selectable alternate function
17	GPIO.1	Digital Input/Output ²	GPIO or selectable alternate function
18	GPIO.0	Digital Input/Output ²	GPIO or selectable alternate function
19	GPIO.9	Digital Input/Output ²	GPIO
	BUTTONS	Analog Input	Analog input for sensing buttons connected via resistor ladder
20	GPIO.8	Digital Input/Output ²	GPIO
	ADC	Analog Input	General purpose analog input, readable via I/O protocol
21	CFGMODEb	Digital Input	Configuration Mode input. If CFGMODEb is low when RSTb becomes deasserted, CP2615 enters Configuration Mode.
22	GPIO.10	Digital Input/Output ²	GPIO
	RESETOUTb	Digital Output ²	Output signal controllable via I ² C command string (typically connected to codec reset pin)

Pin #	Name	Function	Description ¹
23	GPIO.14	Digital Input/Output ²	GPIO
	RX	Digital Input	UART receive data
24	GPIO.13	Digital Input/Output ²	GPIO
	TX	Digital Output	UART transmit data
25	GPIO.12	Digital Input/Output ²	GPIO
	CLKOUT	Digital Output	Configurable clock output
26	I2S_MCLK	Digital Output	I ² S interface: Master clock output
27	GPIO.11	Digital Input/Output ²	GPIO
	RTS	Digital Output	UART RTS flow-control output
28	I2S_LRCLK	Digital Output	I ² S interface: Left/right clock output
29	I2C_SCL	Digital Input/Output ²	I ² C interface: Serial clock input/output
30	I2C_SDA	Digital Input/Output ²	I ² C interface: Serial data input/output
31	GPIO.15	Digital Input/Output ²	GPIO
	CTS	Digital Input	UART CTS flow-control input
32	I2S_SDOUT	Digital Output ²	I ² S interface: Serial data output

Note:

1. GPIO: General Purpose Input or Output.
2. For the specified function, pin can be left unconnected if not used
3. Requires external pullup resistor to V_{DD}.

5. QFN32 Package Specifications

5.1 QFN32 Package Dimensions

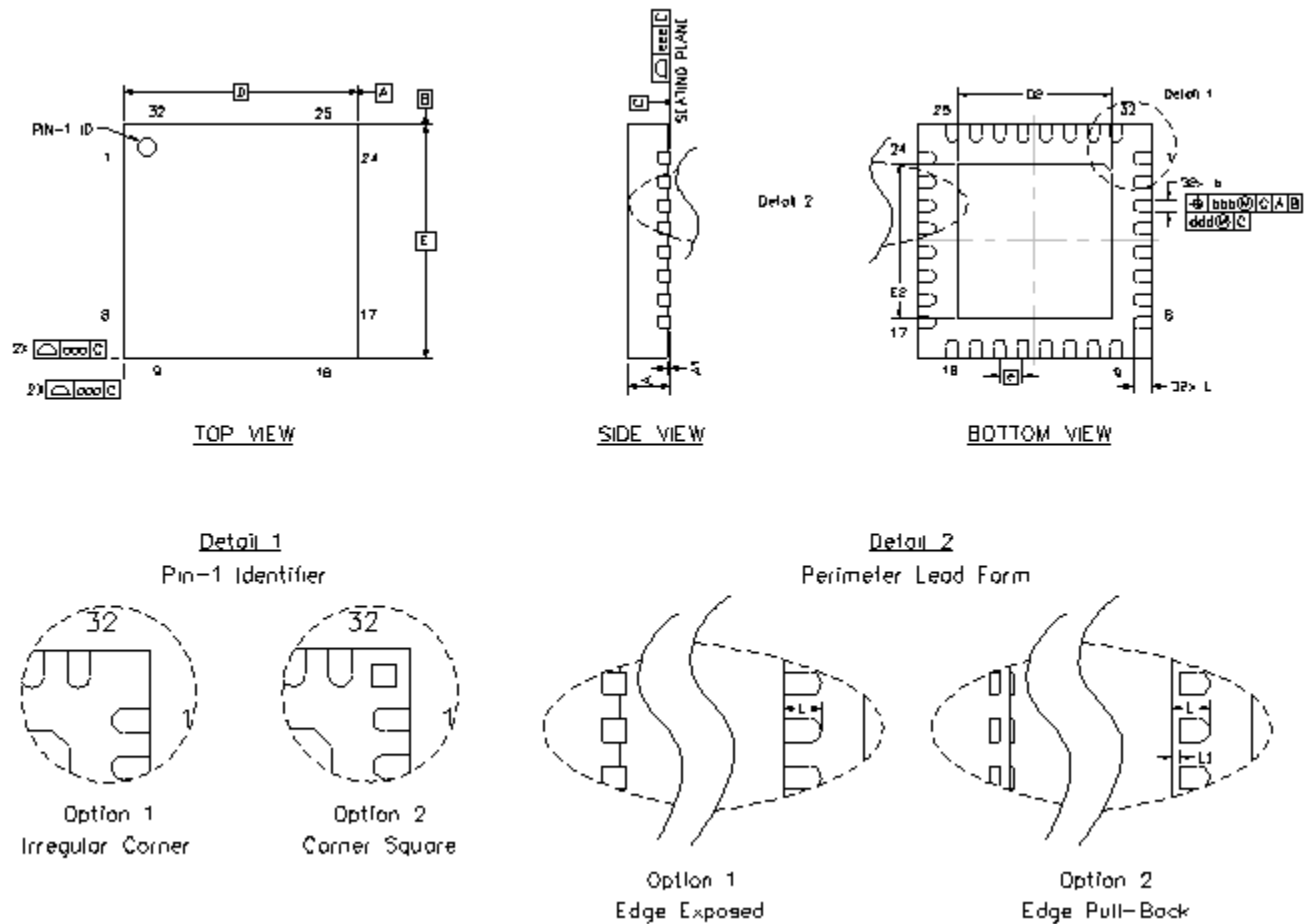

Figure 5.1. QFN32 Package Drawing

Table 5.1. QFN32 Package Dimensions

Dimension	Min	Typ	Max
A	0.80	0.85	0.90
A1	0.00	0.02	0.05
b	0.18	0.25	0.30
D	5.00 BSC.		
D2	3.20	3.30	3.40
e	0.50 BSC.		
E	5.00 BSC.		
E2	3.20	3.30	3.40
L	0.30	0.40	0.50

Dimension	Min	Typ	Max
L1	0.00	—	0.15
aaa	—	—	0.10
bbb	—	—	0.10
ddd	—	—	0.05
eee	—	—	0.08

Note:

1. All dimensions shown are in millimeters (mm) unless otherwise noted.
2. Dimensioning and Tolerancing per ANSI Y14.5M-1994.
3. This drawing conforms to the JEDEC Solid State Outline MO-220, variation VHHD except for custom features D2, E2, and L which are toleranced per supplier designation.
4. Recommended card reflow profile is per the JEDEC/IPC J-STD-020 specification for Small Body Components.

5.2 QFN32 PCB Land Pattern

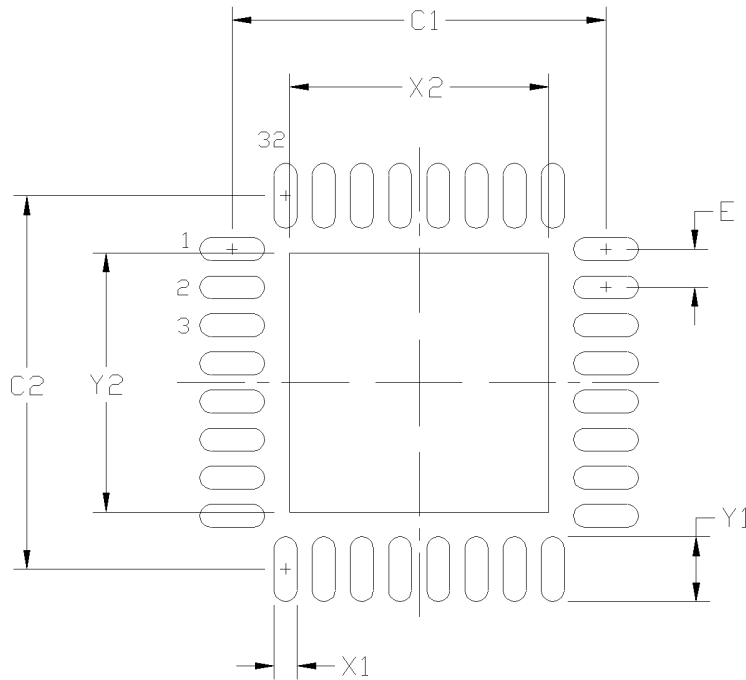

Figure 5.2. QFN32 Recommended PCB Land Pattern

Table 5.2. QFN32 PCB Land Pattern Dimensions

Dimension	Min	Max
C1	4.80	4.90
C2	4.80	4.90
E	0.50 BSC	
X1	0.20	0.30
X2	3.20	3.40
Y1	0.75	0.85
Y2	3.20	3.40

Dimension	Min	Max
Note:		
General		
<ol style="list-style-type: none"> All dimensions shown are in millimeters (mm) unless otherwise noted. This Land Pattern Design is based on the IPC-7351 guidelines. 		
Solder Mask Design		
<ol style="list-style-type: none"> All metal pads are to be non-solder mask defined (NSMD). Clearance between the solder mask and the metal pad is to be 60 µm minimum, all the way around the pad. 		
Stencil Design		
<ol style="list-style-type: none"> A stainless steel, laser-cut and electro-polished stencil with trapezoidal walls should be used to assure good solder paste release. The stencil thickness should be 0.125 mm (5 mils). The ratio of stencil aperture to land pad size should be 1:1 for all perimeter pads. A 3x3 array of 1.0 mm square openings on 1.2 mm pitch should be used for the center ground pad. 		
Card Assembly		
<ol style="list-style-type: none"> A No-Clean, Type-3 solder paste is recommended. The recommended card reflow profile is per the JEDEC/IPC J-STD-020 specification for Small Body Components. 		

5.3 QFN32 Package Marking

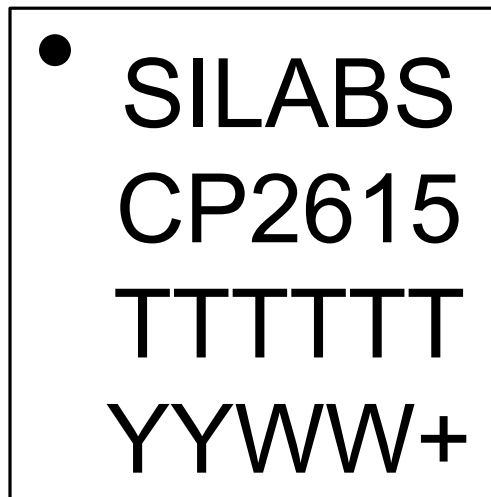

Figure 5.3. QFN32 Package Marking

The package marking consists of:

- TTTTTT – A trace or manufacturing code. The first digit of this code is the hardware revision (i.e. B).
- YY – The last two digits of the assembly year.
- WW – The two-digit workweek when the device was assembled.
- + – Indicates the device is lead free and RoHS compliant.

6. Relevant Application Notes

The following Application Note is applicable to the CP2615. Please contact a Silicon Labs representative to access the latest version of this application note and its accompanying software.

- *AN1044: CP2615 Customization User Guide*—this application note describes the steps required to customize a CP2615 fixed-function USB device.

7. Revision History

7.1 Revision 1.1

April 11th, 2017

Corrected the regulator output voltage listed in [1. Feature List and Ordering Information](#).

Filled in all TBDs in [2. Electrical Specifications](#).

Updated the typical specification for Supply Current - Suspend Mode and removed Supply Current - USB Pull-up in [2.1.1 Recommended Operating Conditions](#).

Updated the note in [2.1.8 Analog Output/Input](#) to specify measurements are taken in asynchronous mode.

Updated all references to *AN1044: CP2615 Customization User Guide* to refer to the correct document.

Updated the maximum string sizes in [3.6.1.1 Command Strings for Codec Configuration](#).

Updated the synchronization option descriptions in [3.1.4 Audio Endpoint Synchronizations](#) and [3.5.1.4 Audio Options](#).

Updated the title for this section: [3.7.2 USB 3.3 V Self-Powered Connection](#).

7.2 Revision 1.0

October 14th, 2016

Revision updated with no changes to the document.

7.3 Revision 0.2

May 18th, 2016

Added all content except for the front page and features.

7.4 Revision 0.1

May 13th, 2016

Initial release.

Silicon Labs

Simplicity Studio™4



Simplicity Studio

One-click access to MCU and wireless tools, documentation, software, source code libraries & more. Available for Windows, Mac and Linux!



IoT Portfolio
www.silabs.com/loT



SW/HW
www.silabs.com/simplicity



Quality
www.silabs.com/quality



Support and Community
community.silabs.com

Disclaimer

Silicon Labs intends to provide customers with the latest, accurate, and in-depth documentation of all peripherals and modules available for system and software implementers using or intending to use the Silicon Labs products. Characterization data, available modules and peripherals, memory sizes and memory addresses refer to each specific device, and "Typical" parameters provided can and do vary in different applications. Application examples described herein are for illustrative purposes only. Silicon Labs reserves the right to make changes without further notice and limitation to product information, specifications, and descriptions herein, and does not give warranties as to the accuracy or completeness of the included information. Silicon Labs shall have no liability for the consequences of use of the information supplied herein. This document does not imply or express copyright licenses granted hereunder to design or fabricate any integrated circuits. The products are not designed or authorized to be used within any Life Support System without the specific written consent of Silicon Labs. A "Life Support System" is any product or system intended to support or sustain life and/or health, which, if it fails, can be reasonably expected to result in significant personal injury or death. Silicon Labs products are not designed or authorized for military applications. Silicon Labs products shall under no circumstances be used in weapons of mass destruction including (but not limited to) nuclear, biological or chemical weapons, or missiles capable of delivering such weapons.

Trademark Information

Silicon Laboratories Inc.®, Silicon Laboratories®, Silicon Labs®, SiLabs® and the Silicon Labs logo®, Bluegiga®, Bluegiga Logo®, Clockbuilder®, CMEMS®, DSPLL®, EFM®, EFM32®, EFR®, Ember®, Energy Micro, Energy Micro logo and combinations thereof, "the world's most energy friendly microcontrollers", Ember®, EZLink®, EZRadio®, EZRadioPRO®, Gecko®, ISOModem®, Precision32®, ProSLIC®, Simplicity Studio®, SiPHY®, Telegesis, the Telegesis Logo®, USBXpress® and others are trademarks or registered trademarks of Silicon Labs. ARM, CORTEX, Cortex-M3 and THUMB are trademarks or registered trademarks of ARM Holdings. Keil is a registered trademark of ARM Limited. All other products or brand names mentioned herein are trademarks of their respective holders.



SILICON LABS

Silicon Laboratories Inc.
400 West Cesar Chavez
Austin, TX 78701
USA

<http://www.silabs.com>