

EFM32PG26 SoC Family Data Sheet



The EFM32PG26 MCU family of microcontrollers is part of the Series 2 portfolio. EFM32PG26 MCU's are ideal for enabling energy-friendly embedded applications.

The highly efficient solution contains an 80 MHz Cortex-M33 with rich analog and communication peripherals to provide an industry-leading, energy-efficient MCU for consumer and industrial applications.

Target applications include:

- Metering
- Industrial Automation
- Appliances
- Portable Medical Devices

KEY FEATURES
• 32-bit ARM® Cortex®-M33 core with 80 MHz maximum operating frequency
• Up to 3200 kB of flash and 512 kB of RAM
• Energy efficient design with low active and sleep currents
• Secure Vault™
• AI/ML Hardware Accelerator

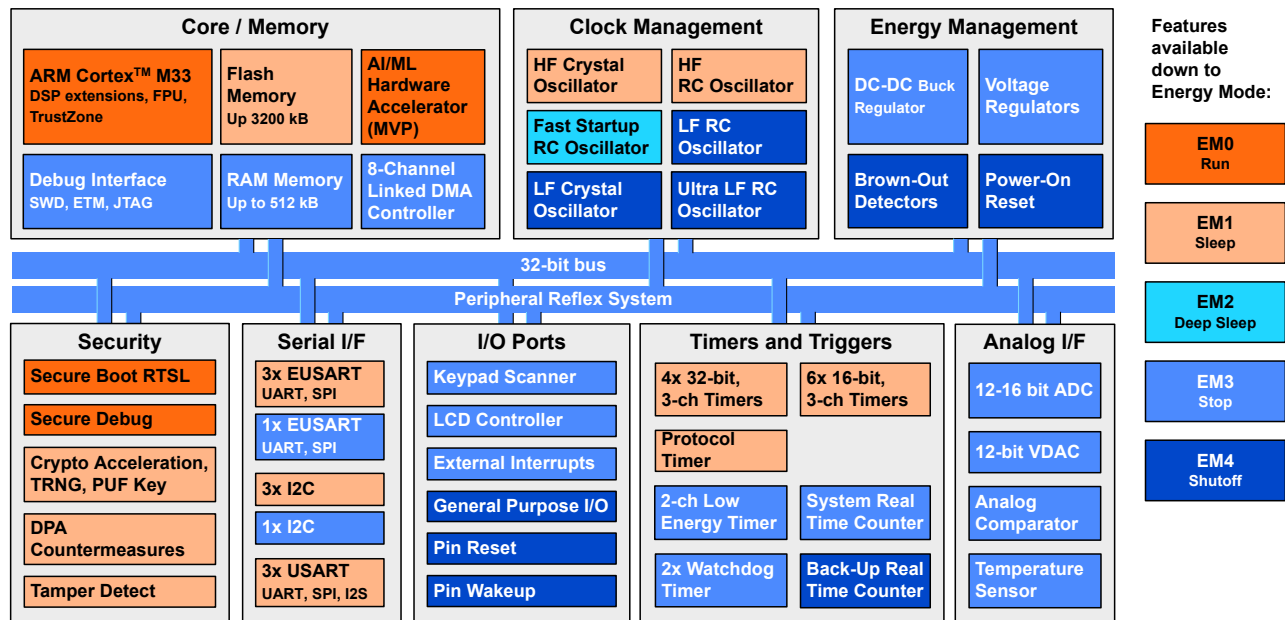

1. Feature List

The EFM32PG26 highlighted features are listed below.

- **Low-power System-on-Chip**
 - High-performance 32-bit 80 MHz ARM Cortex[®]-M33 with DSP instruction and floating-point unit for efficient signal processing
 - Up to 3200 kB flash program memory
 - Up to 512 kB RAM data memory
 - Matrix Vector Processor for AI/ML acceleration
- **Low System Energy Consumption**
 - 42.8 μ A/MHz in Active Mode (EM0) at 80 MHz
 - 1.4 μ A EM2 DeepSleep current (16 kB RAM retention and RTC running from LFRCO)
- **Secure Vault**
 - Hardware Cryptographic Acceleration for AES128/192/256, ChaCha20-Poly1305, SHA-1, SHA-2/256/384/512, ECDSA +ECDH(P-192, P-256, P-384, P-521), Ed25519 and Curve25519, J-PAKE, PBKDF2
 - True Random Number Generator (TRNG)
 - ARM[®] TrustZone[®]
 - Secure Boot (Root of Trust Secure Loader)
 - Secure Debug Unlock
 - DPA Countermeasures
 - Secure Key Management with PUF
 - Anti-Tamper
 - Secure Attestation
 - PSA L3 certified
- **Wide Selection of MCU Peripherals**
 - Analog to Digital Converter (IADC)
 - 12, 16, or 20-bit output
 - Select OPNs support High Speed Mode (up to 2 Msps) and High Accuracy Mode (up to 16 bits ENOB at 3.8 ksps)
 - 2 \times Analog Comparator (ACMP)
 - 2 \times Digital to Analog Converter (VDAC)
 - Up to 64 General Purpose I/O pins with output state retention and asynchronous interrupts
 - 8 Channel DMA Controller (LDMA)
 - 20 Channel Peripheral Reflex System (PRS)
 - 6 \times 16-bit Timer/Counter with 3 Compare/Capture/PWM channels (TIMER2/3/4)
 - 4 \times 32-bit Timer/Counter with 3 Compare/Capture/PWM channels (TIMER0/1)
 - 2 \times 32-bit Real Time Counter (SYSRTC/BURTC)
 - 24-bit Low Energy Timer for waveform generation (LETIMER)
 - 16-bit Pulse Counter with asynchronous operation (PCNT)
 - 2 \times Watchdog Timer (WDOG)
 - 3 \times Universal Synchronous/Asynchronous Receiver/Transmitter (USART), supporting UART/SPI/SmartCard (ISO 7816)/IrDA/I²S
 - 4 \times Enhanced Universal Synchronous/Asynchronous Receiver/Transmitter (EUSART) supporting UART/SPI/DALI/IrDA
 - 4 \times I²C interface with SMBus support
 - Low-Frequency RC Oscillator with precision mode to replace 32 kHz sleep crystal (LFRCO)
 - Keypad scanner supporting up to 6x8 matrix (KEYSCAN)
 - Integrated Low-Energy LCD Controller supporting up to 4 \times 40 segments (LCD)
 - Die temperature sensor with \pm 1.5 $^{\circ}$ C accuracy after single-point calibration
- **Wide Operating Range**
 - 1.71 V to 3.8 V single power supply
 - -40 $^{\circ}$ C to 125 $^{\circ}$ C
- **Packages**
 - **QFN48** 6 \times 6 \times 0.85 mm
 - **QFN68** 8 \times 8 \times 0.85 mm
 - **BGA136** 7 \times 7 \times 0.82 mm

2. Ordering Information

Table 2.1. Ordering Information

Ordering Code	Flash (KB)	RAM (KB)	Secure Vault	IADC High-Speed / High-Accuracy	Matrix Vector Processor	Dedicated ADC Inputs	GPIO	Package / Pin-out
EFM32PG26B501F3200IM68-B	3200	512	High	Yes	No	4	48	QFN68 / MCU
EFM32PG26B501F3200IM48-B	3200	512	High	Yes	No	4	28	QFN48 / MCU
EFM32PG26B501F3200IL136-B	3200	512	High	Yes	No	4	64	BGA136 / MCU
EFM32PG26B500F3200IM68-B	3200	512	High	Yes	Yes	4	48	QFN68 / MCU
EFM32PG26B500F3200IM48-B	3200	512	High	Yes	Yes	4	28	QFN48 / MCU
EFM32PG26B500F3200IL136-B	3200	512	High	Yes	Yes	4	64	BGA136 / MCU
EFM32PG26B301F2048IM68-B	2048	256	High	Yes	No	4	48	QFN68 / MCU
EFM32PG26B301F2048IL136-B	2048	256	High	Yes	No	4	64	BGA136 / MCU
EFM32PG26B301F1024IM68-B	1024	256	High	Yes	No	4	48	QFN68 / MCU
EFM32PG26B301F1024IL136-B	1024	256	High	Yes	No	4	64	BGA136 / MCU
EFM32PG26B101F512IM68-B	512	128	High	Yes	No	4	48	QFN68 / MCU
EFM32PG26B101F512IL136-B	512	128	High	Yes	No	4	64	BGA136 / MCU

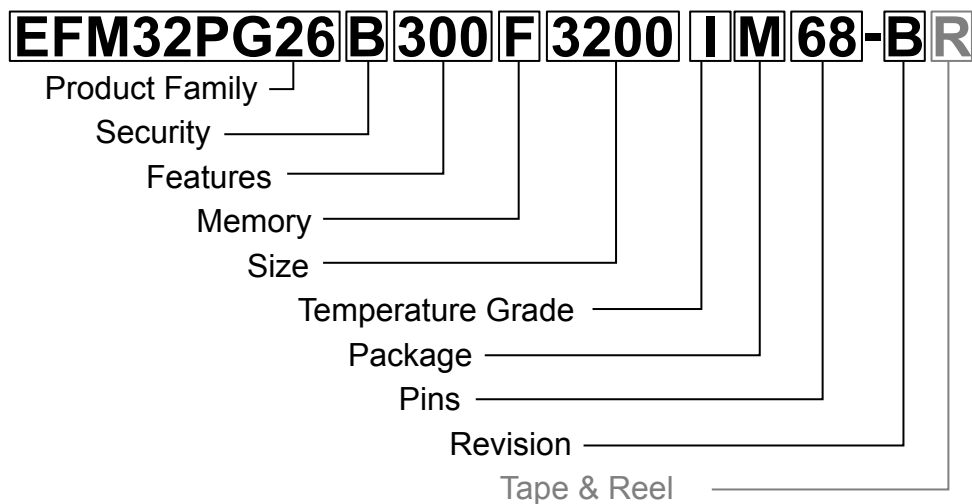

Figure 2.1. Ordering Code Key

Field	Options
Product Family	<ul style="list-style-type: none"> • EFM32PG26: Pearl Gecko 26 Family
Security	<ul style="list-style-type: none"> • A: Secure Vault Mid • B: Secure Vault High
Features [f1][f2][f3]	<ul style="list-style-type: none"> • f1 <ul style="list-style-type: none"> • 0: 128kB RAM • 1: 128kB RAM, IADC High-Speed / High-Accuracy Available • 2: 256kB RAM • 3: 256kB RAM, IADC High-Speed / High-Accuracy Available • 4: 512kB RAM • 5: 512kB RAM, IADC High-Speed / High-Accuracy Available • f2 <ul style="list-style-type: none"> • 0: No feature enabled • f3 <ul style="list-style-type: none"> • 0: Matrix Vector Processor (MVP) enabled • 1: Matrix Vector Processor (MVP) disabled
Memory	<ul style="list-style-type: none"> • F: Flash
Size	<ul style="list-style-type: none"> • Memory Size in kBytes
Temperature Grade	<ul style="list-style-type: none"> • I: -40 to +125 °C
Package	<ul style="list-style-type: none"> • M: QFN • L: BGA
Pins	<ul style="list-style-type: none"> • Number of Package Pins
Revision	<ul style="list-style-type: none"> • B: Revision B
Tape & Reel	<ul style="list-style-type: none"> • R: Tape & Reel (optional)

Table of Contents

1. Feature List	2
2. Ordering Information	3
3. System Overview	9
3.1 Introduction	9
3.2 General Purpose Input/Output (GPIO)	9
3.3 Keypad Scanner (KEYSCAN)	10
3.4 Clocking	10
3.4.1 Clock Management Unit (CMU)	10
3.4.2 Internal and External Oscillators	10
3.5 Counters/Timers and PWM	10
3.5.1 Timer/Counter (TIMER)	10
3.5.2 Low Energy Timer (LETIMER)	10
3.5.3 System Real Time Clock with Capture (SYSRTC)	10
3.5.4 Back-Up Real Time Counter (BURTC)	11
3.5.5 Watchdog Timer (WDOG)	11
3.6 Communications and Other Digital Peripherals	11
3.6.1 Universal Synchronous/Asynchronous Receiver/Transmitter (USART)	11
3.6.2 Enhanced Universal Synchronous/Asynchronous Receiver/Transmitter (EUSART)	11
3.6.3 Inter-Integrated Circuit Interface (I ² C)	11
3.6.4 Peripheral Reflex System (PRS)	11
3.7 Secure Vault Features	12
3.7.1 Secure Boot with Root of Trust and Secure Loader (RTSL)	12
3.7.2 Cryptographic Accelerator	13
3.7.3 True Random Number Generator	13
3.7.4 Secure Debug with Lock/Unlock	13
3.7.5 DPA Countermeasures	13
3.7.6 Secure Key Management with PUF	13
3.7.7 Anti-Tamper	14
3.7.8 Secure Attestation	14
3.8 Analog	14
3.8.1 Analog to Digital Converter (IADC)	14
3.8.2 Analog Comparator (ACMP)	14
3.8.3 Digital to Analog Converter (VDAC)	15
3.8.4 Liquid Crystal Display Driver (LCD)	15
3.9 Power	16
3.9.1 Energy Management Unit (EMU)	16
3.9.2 Voltage Scaling	16
3.9.3 DC-DC Converter	16
3.9.4 Power Domains	17
3.10 Reset Management Unit (RMU)	17
3.11 Core, Memory, and Accelerators	18
3.11.1 Processor Core	18

3.11.2	Memory System Controller (MSC)	.18
3.11.3	Linked Direct Memory Access Controller (LDMA)	.18
3.11.4	Matrix Vector Processor (MVP)	.18
3.12	Memory Map	.19
3.13	Configuration Summary	.20
4.	Electrical Specifications	.21
4.1	Electrical Characteristics	.21
4.2	Absolute Maximum Ratings	.22
4.3	General Operating Conditions	.23
4.4	DC-DC Converter	.24
4.4.1	DC-DC Maximum Load Current	.25
4.4.2	PFM Mode	.26
4.4.3	PFMX Mode	.26
4.5	Thermal Characteristics	.27
4.6	Current Consumption	.28
4.6.1	MCU Current Consumption using DC-DC at 3.0 V Input	.28
4.6.2	MCU Current Consumption at 3.0 V	.31
4.6.3	MCU Current Consumption at 1.8 V	.33
4.7	Flash Characteristics	.35
4.8	Energy Mode Wake-up and Entry Times	.36
4.9	Oscillators	.37
4.9.1	High Frequency Crystal Oscillator (HFXO)	.37
4.9.2	Low Frequency Crystal Oscillator (LFXO)	.38
4.9.3	High Frequency RC Oscillator (HFRCO)	.39
4.9.4	Fast Start-Up RC Oscillator (FSRCO)	.40
4.9.5	Precision Low Frequency RC Oscillator (LFRCO)	.41
4.9.6	Ultra Low Frequency RC Oscillator (ULFRCO)	.41
4.10	GPIO Pins (GPIO)	.42
4.11	Analog to Digital Converter (IADC)	.44
4.12	Analog Comparator (ACMP)	.50
4.13	Digital to Analog Converter (VDAC)	.52
4.14	Temperature Sensor	.54
4.15	Brown Out Detectors	.55
4.15.1	DVDD BOD	.55
4.15.2	Low-Energy DVDD BOD	.55
4.15.3	AVDD and IOVDD BODs	.56
4.16	Pulse Counter (PCNT)	.56
4.17	USART SPI Main Timing	.57
4.17.1	USART SPI Main Timing, Voltage Scaling = VSCALE2	.58
4.17.2	USART SPI Main Timing, Voltage Scaling = VSCALE1	.58
4.18	USART SPI Secondary Timing	.59
4.18.1	USART SPI Secondary Timing, Voltage Scaling = VSCALE2	.60

4.18.2	USART SPI Secondary Timing, Voltage Scaling = VSCALE1	.60
4.19	EUSART SPI Main Timing.	.61
4.19.1	EUSART SPI Main Timing, Voltage Scaling = VSCALE2	.61
4.19.2	EUSART SPI Main Timing, Voltage Scaling = VSCALE1	.62
4.20	EUSART SPI Secondary Timing	.63
4.20.1	EUSART SPI Secondary Timing, Voltage Scaling = VSCALE2	.63
4.20.2	EUSART SPI Secondary Timing, Voltage Scaling = VSCALE1	.64
4.20.3	EUSART SPI Secondary Timing, Voltage Scaling = VSCALE0	.64
4.21	I2C Electrical Specifications	.65
4.21.1	I2C Standard-mode (Sm)	.65
4.21.2	I2C Fast-mode (Fm)	.66
4.21.3	I2C Fast-mode Plus (Fm+)	.67
4.22	Boot Timing	.67
4.23	Crypto Operation Timing for SE Manager API	.69
4.24	Crypto Operation Average Current for SE Manager API	.71
4.25	Matrix Vector Processor (MVP)	.73
4.26	LCD	.74
4.27	Typical Performance Curves	.74
4.27.1	Supply Current	.75
4.27.2	DC-DC Converter	.77
4.27.4	GPIO	.78
5.	Typical Connections	.79
5.1	Power	.79
5.2	Other Connections.	.80
6.	Pin Definitions	.81
6.1	BGA136 / MCU Device Pinout	.81
6.2	QFN68 / MCU Device Pinout	.84
6.3	QFN48 / MCU Device Pinout	.86
6.4	Alternate Function Table.	.88
6.5	Analog Peripheral Connectivity	.90
6.6	Digital Peripheral Connectivity	.91
7.	QFN48 Package Specifications.	.97
7.1	QFN48 Package Dimensions	.97
7.2	QFN48 PCB Land Pattern	.99
7.3	QFN48 Package Marking	.100
8.	QFN68 Package Specifications.	.101
8.1	QFN68 Package Dimensions	.101
8.2	QFN68 PCB Land Pattern	.103
8.3	QFN68 Package Marking	.105

- 9. BGA136 Package Specifications 106**
 - 9.1 BGA136 Package Dimensions 106
 - 9.2 BGA136 PCB Land Pattern 108
 - 9.3 BGA136 Package Marking 109
- 10. Revision History. 110**

3. System Overview

3.1 Introduction

The EFM32PG26 Gecko product family is well suited for any battery operated application as well as other systems requiring high performance and low energy consumption. This section gives a short introduction to the MCU system. The detailed functional description can be found in the EFM32PG26 Reference Manual

A block diagram of the EFM32PG26 family is shown in [Figure 3.1 Detailed EFM32PG26 Block Diagram on page 9](#). The diagram shows a superset of features available on the family, which vary by OPN. For more information about specific device features, consult .

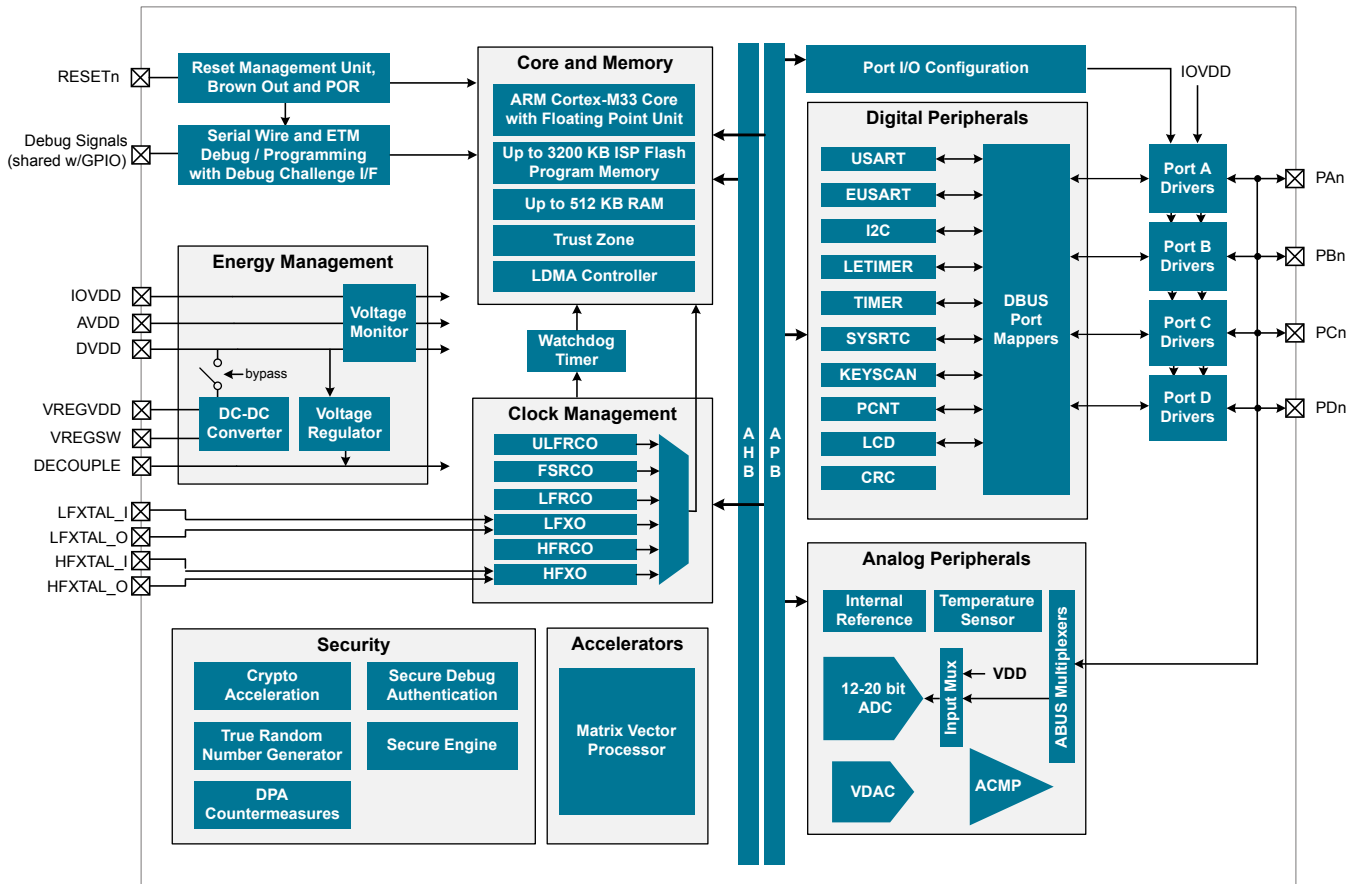

Figure 3.1. Detailed EFM32PG26 Block Diagram

3.2 General Purpose Input/Output (GPIO)

EFM32PG26 has up to 64 General Purpose Input/Output pins. Each GPIO pin can be individually configured as either an output or input. More advanced configurations including open-drain, open-source, and glitch-filtering can be configured for each individual GPIO pin. The GPIO pins can be overridden by peripheral connections, like SPI communication. Each peripheral connection can be routed to several GPIO pins on the device. The input value of a GPIO pin can be routed through the Peripheral Reflex System to other peripherals. The GPIO subsystem supports asynchronous external pin interrupts.

All of the pins on ports A and port B are EM2 capable. These pins may be used by Low-Energy peripherals in EM2/3 and may also be used as EM2/3 pin wake-ups. Pins on ports C and D are latched/retained in their current state when entering EM2 until EM2 exit upon which internal peripherals could once again drive those pads.

A few GPIOs also have wake functionality down to EM4. These pins are listed in the Alternate Function Table with the function GPIO.EM4WU.

3.3 Keypad Scanner (KEYSCAN)

A low-energy keypad scanner (KEYSCAN) is included, which can scan up to a 6 x 8 matrix of keyboard switches. The KEYSCAN peripheral contains logic for debounce and settling time, allowing it to scan through the switch matrix autonomously in EM0 and EM1, and interrupt the processor when a key press is detected. A wake-on-keypress feature is also supported, allowing for the detection of any key press down to EM3.

3.4 Clocking

3.4.1 Clock Management Unit (CMU)

The Clock Management Unit controls oscillators and clocks in the EFM32PG26. Individual enabling and disabling of clocks to all peripheral modules is performed by the CMU. The CMU also controls enabling and configuration of the oscillators. A high degree of flexibility allows software to optimize energy consumption in any specific application by minimizing power dissipation in unused peripherals and oscillators.

3.4.2 Internal and External Oscillators

The EFM32PG26 supports two crystal oscillators and fully integrates four RC oscillators, listed below.

- A high frequency crystal oscillator (HFXO) with integrated load capacitors, tunable in small steps, provides a precise timing reference for the MCU. The HFXO provides excellent RF clocking performance using a 39.0 MHz crystal. The HFXO can also support an external clock source such as a TCXO for applications that require an extremely accurate clock frequency over temperature.
- A 32.768 kHz crystal oscillator (LFXO) provides an accurate timing reference for low energy modes.
- An integrated high frequency RC oscillator (HFRCO) is available for the MCU system, when crystal accuracy is not required. The HFRCO employs fast start-up at minimal energy consumption combined with a wide frequency range, from 1 MHz to 80 MHz.
- An integrated fast start-up RC oscillator (FSRRCO) that runs at a fixed 20 MHz
- An integrated low frequency 32.768 kHz RC oscillator (LFRCO) for low power operation without an external crystal. Precision mode enables periodic recalibration against the 39.0 MHz HFXO crystal to improve accuracy to +/- 500 ppm, suitable for BLE sleep interval timing.
- An integrated ultra-low frequency 1 kHz RC oscillator (ULFRCO) is available to provide a timing reference at the lowest energy consumption in low energy modes.

3.5 Counters/Timers and PWM

3.5.1 Timer/Counter (TIMER)

TIMER peripherals keep track of timing, count events, generate PWM outputs and trigger timed actions in other peripherals through the Peripheral Reflex System (PRS). The core of each TIMER is a 16-bit or 32-bit counter with up to 3 compare/capture channels. Each channel is configurable in one of three modes. In capture mode, the counter state is stored in a buffer at a selected input event. In compare mode, the channel output reflects the comparison of the counter to a programmed threshold value. In PWM mode, the TIMER supports generation of pulse-width modulation (PWM) outputs of arbitrary waveforms defined by the sequence of values written to the compare registers. In addition some timers offer dead-time insertion.

See [3.13 Configuration Summary](#) for information on the feature set of each timer.

3.5.2 Low Energy Timer (LETIMER)

The unique LETIMER is a 24-bit timer that is available in energy mode EM0 Active, EM1 Sleep, EM2 Deep Sleep, and EM3 Stop. This allows it to be used for timing and output generation when most of the device is powered down, allowing simple tasks to be performed while the power consumption of the system is kept at an absolute minimum. The LETIMER can be used to output a variety of waveforms with minimal software intervention. The LETIMER is connected to the Peripheral Reflex System (PRS), and can be configured to start counting on compare matches from other peripherals such as the Real Time Clock.

3.5.3 System Real Time Clock with Capture (SYSRTC)

The System Real Time Clock (SYSRTC) is a 32-bit counter providing timekeeping down to EM3. The SYSRTC can be clocked by any of the on-board low-frequency oscillators, and it is capable of providing system wake-up at user defined intervals.

3.5.4 Back-Up Real Time Counter (BURTC)

The Back-Up Real Time Counter (BURTC) is a 32-bit counter providing timekeeping in all energy modes, including EM4. The BURTC can be clocked by any of the on-board low-frequency oscillators, and it is capable of providing system wake-up at user-defined intervals.

3.5.5 Watchdog Timer (WDOG)

The watchdog timer can act both as an independent watchdog or as a watchdog synchronous with the CPU clock. It has windowed monitoring capabilities, and can generate a reset or different interrupts depending on the failure mode of the system. The watchdog can also monitor autonomous systems driven by the Peripheral Reflex System (PRS).

3.6 Communications and Other Digital Peripherals

3.6.1 Universal Synchronous/Asynchronous Receiver/Transmitter (USART)

The Universal Synchronous/Asynchronous Receiver/Transmitter is a flexible serial I/O module. It supports full duplex asynchronous UART communication with hardware flow control as well as RS-485, SPI, MicroWire and 3-wire. It can also interface with devices supporting:

- ISO7816 SmartCards
- IrDA
- I²S

3.6.2 Enhanced Universal Synchronous/Asynchronous Receiver/Transmitter (EUSART)

The Enhanced Universal Synchronous/Asynchronous Receiver/Transmitter supports full duplex asynchronous UART communication with hardware flow control, RS-485, and IrDA support. The EUSART also supports high-speed SPI. In EM0 and EM1 the EUSART provides a high-speed, buffered communication interface.

When routed to GPIO ports A or B, the EUSART0 may also be used in a low-energy mode and operate in EM2. A 32.768 kHz clock source allows full duplex UART communication up to 9600 baud. EUSART0 can also act as a SPI secondary device in EM2 and EM3, and wake the system when data is received from an external bus controller.

3.6.3 Inter-Integrated Circuit Interface (I²C)

The I²C module provides an interface between the MCU and a serial I²C bus. It is capable of acting as a main or secondary interface and supports multi-drop buses. Standard-mode, fast-mode and fast-mode plus speeds are supported, allowing transmission rates from 10 kbit/s up to 1 Mbit/s. Bus arbitration and timeouts are also available, allowing implementation of an SMBus-compliant system. The interface provided to software by the I²C module allows precise timing control of the transmission process and highly automated transfers. Automatic recognition of addresses is provided in active and low energy modes. Not all instances of I²C are available in all energy modes.

3.6.4 Peripheral Reflex System (PRS)

The Peripheral Reflex System provides a communication network between different peripheral modules without software involvement. Peripheral modules producing Reflex signals are called producers. The PRS routes Reflex signals from producers to consumer peripherals which in turn perform actions in response. Edge triggers and other functionality such as simple logic operations (AND, OR, NOT) can be applied by the PRS to the signals. The PRS allows peripherals to act autonomously without waking the MCU core, saving power.

3.7 Secure Vault Features

A dedicated hardware secure engine containing its own CPU enables the Secure Vault functions. It isolates cryptographic functions and data from the host Cortex-M33 core, and provides several additional security features. The EFM32PG26 family includes devices with Secure Vault High and Secure Vault Mid capabilities, which are summarized in the table below.

Table 3.1. Secure Vault Features

Feature	Secure Vault Mid	Secure Vault High
True Random Number Generator (TRNG)	Yes	Yes
Secure Boot with Root of Trust and Secure Loader (RTSL)	Yes	Yes
Secure Debug with Lock/Unlock	Yes	Yes
DPA Countermeasures	Yes	Yes
Anti-Tamper		Yes
Secure Attestation		Yes
Secure Key Management		Yes
Symmetric Encryption	<ul style="list-style-type: none"> AES 128 / 192 / 256 bit <ul style="list-style-type: none"> ECB, CTR, CBC, CFB, CCM, GCM, CBC-MAC, and GMAC 	<ul style="list-style-type: none"> AES 128 / 192 / 256 bit <ul style="list-style-type: none"> ECB, CTR, CBC, CFB, CCM, GCM, CBC-MAC, and GMAC ChaCha20
Public Key Encryption - ECDSA / ECDH / EdDSA	<ul style="list-style-type: none"> p192 and p256 Curve25519 (ECDH)¹ Ed25519 (EdDSA)¹ 	<ul style="list-style-type: none"> p192, p256, p384 and p521 Curve25519 (ECDH) Ed25519 (EdDSA)
Key Derivation	<ul style="list-style-type: none"> ECJ-PAKE p192 and p256 	<ul style="list-style-type: none"> ECJ-PAKE p192, p256, p384, and p521 PBKDF2 HKDF
Hashes	<ul style="list-style-type: none"> SHA-1 SHA-2/256 	<ul style="list-style-type: none"> SHA-1 SHA-2 256, 384, and 512 Poly1305
Note:		
1. These curves are supported in devices running SE v2.1.7 and higher		

3.7.1 Secure Boot with Root of Trust and Secure Loader (RTSL)

The Secure Boot with RTSL authenticates a chain of trusted firmware that begins from an immutable memory (ROM).

It prevents malware injection, prevents rollback, ensures that only authentic firmware is executed, and protects Over The Air updates.

For more information about this feature, see [AN1218: Series 2 Secure Boot with RTSL](#).

3.7.2 Cryptographic Accelerator

The Cryptographic Accelerator is an autonomous hardware accelerator with Differential Power Analysis (DPA) countermeasures to protect keys.

It supports AES encryption and decryption with 128/192/256-bit keys, ChaCha20 encryption, and Elliptic Curve Cryptography (ECC) to support public key operations, and hashes.

Supported block cipher modes of operation for AES include:

- ECB (Electronic Code Book)
- CTR (Counter Mode)
- CBC (Cipher Block Chaining)
- CFB (Cipher Feedback)
- GCM (Galois Counter Mode)
- CCM (Counter with CBC-MAC)
- CBC-MAC (Cipher Block Chaining Message Authentication Code)
- GMAC (Galois Message Authentication Code)

The Cryptographic Accelerator accelerates Elliptic Curve Cryptography and supports the NIST (National Institute of Standards and Technology) recommended curves including P-192, P-256, P-384, and P-521 for ECDH (Elliptic Curve Diffie-Hellman) key derivation, and ECDSA (Elliptic Curve Digital Signature Algorithm) sign and verify operations. Also supported is the non-NIST Curve25519 for ECDH and Ed25519 for EdDSA (Edwards-curve Digital Signature Algorithm) sign and verify operations.

Secure Vault also supports ECJ-PAKE (Elliptic Curve variant of Password Authenticated Key Exchange by Juggling) and PBKDF2 (Password-Based Key Derivation Function 2).

Supported hashes include SHA-1, SHA-2/256/384/512 and Poly1305.

This implementation provides a fast and energy efficient solution to state of the art cryptographic needs.

3.7.3 True Random Number Generator

The True Random Number Generator module is a non-deterministic random number generator that harvests entropy from a thermal energy source. It includes start-up health tests for the entropy source as required by NIST SP800-90B and AIS-31 as well as online health tests required for NIST SP800-90C.

The TRNG is suitable for periodically generating entropy to seed an approved pseudo random number generator.

3.7.4 Secure Debug with Lock/Unlock

For obvious security reasons, it is critical for a product to have its debug interface locked before being released in the field.

Secure Vault also provides a secure debug unlock function that allows authenticated access based on public key cryptography. This functionality is particularly useful for supporting failure analysis while maintaining confidentiality of IP and sensitive end-user data.

For more information about this feature, see [AN1190: Series 2 Secure Debug](#).

3.7.5 DPA Countermeasures

The AES and ECC accelerators have Differential Power Analysis (DPA) countermeasures support. This makes it very expensive from a time and effort standpoint to use DPA to recover secret keys.

3.7.6 Secure Key Management with PUF

Key material in Secure Vault High products is protected by "key wrapping" with a standardized symmetric encryption mechanism. This method has the advantage of protecting a virtually unlimited number of keys, limited only by the storage that is accessible by the Cortex-M33, which includes off-chip storage as well. The symmetric key used for this wrapping and unwrapping must be highly secure because it can expose all other key materials in the system. The Secure Vault Key Management system uses a Physically Unclonable Function (PUF) to generate a persistent device-unique seed key on power up to dynamically generate this critical wrapping/unwrapping key which is only visible to the AES encryption engine and is not retained when the device loses power.

3.7.7 Anti-Tamper

Secure Vault High devices provide internal tamper protection which monitors parameters such as voltage, temperature, and electromagnetic pulses as well as detecting tamper of the security sub-system itself. Additionally, 8 external configurable tamper pins support external tamper sources, such as enclosure tamper switches.

For each tamper event, the user is able to select the severity of the tamper response ranging from an interrupt, to a reset, to destroying the PUF reconstruction data which will make all protected key materials un-recoverable and effectively render the device inoperable. The tamper system also has an internal resettable event counter with programmable trigger threshold and refresh periods to mitigate false positive tamper events.

For more information about this feature, see [AN1247: Anti-Tamper Protection Configuration and Use](#).

3.7.8 Secure Attestation

Secure Vault High products support Secure Attestation, which begins with a secure identity that is created during the Silicon Labs manufacturing process. During device production, each device generates its own public/private keypair and securely stores the wrapped private key into immutable OTP memory and this key never leaves the device. The corresponding public key is extracted from the device and inserted into a binary DER-encoded X.509 device certificate, which is signed into a Silicon Labs CA chain and then programmed back into the chip into an immutable OTP memory.

The secure identity can be used to authenticate the chip at any time in the life of the product. The production certification chain can be requested remotely from the product. This certification chain can be used to verify that the device was authentically produced by Silicon Labs. The device unique public key is also bound to the device certificate in the certification chain. A challenge can be sent to the chip at any point in time to be signed by the device private key. The public key in the device certificate can then be used to verify the challenge response, proving that the device has access to the securely-stored private key, which prevents counterfeit products or impersonation attacks.

For more information about this feature, see [AN1268: Authenticating Silicon Labs Devices Using Device Certificates](#).

3.8 Analog

3.8.1 Analog to Digital Converter (IADC)

The IADC is a hybrid architecture combining techniques from both SAR and Delta-Sigma style converters. Flexible controls allow fine-tuned performance and speed to meet the needs of a wide variety of applications. Hardware oversampling reduces system-level noise over multiple front-end samples. The IADC includes integrated voltage reference options. Inputs are selectable from a wide range of sources, including pins configurable as either single-ended or differential.

The IADC supports three operational modes:

- Normal Mode (all devices): Flexible speed and performance, 12-16 bits output resolution
 - 11.7 bits ENOB performance at 1 Msps (OSR = 2)
 - 14.3 bits ENOB performance at 76.9 ksps (OSR = 32)
- High Speed Mode (select devices): Doubles output speed of Normal mode with similar performance, 12-16 bits output resolution
 - 11.7 bits ENOB performance at 2 Msps (OSR = 2)
 - 14.3 bits ENOB performance at 153.8 ksps (OSR = 32)
- High Accuracy Mode (select devices): Optimized for low-rate, high performance applications, with 20 bit output resolution
 - 16 bits ENOB performance at 3.8 ksps (OSR = 256)
 - 15 bits ENOB performance at 15.3 ksps (OSR = 64)

3.8.2 Analog Comparator (ACMP)

The Analog Comparator is used to compare the voltage of two analog inputs, with a digital output indicating which input voltage is higher. Inputs are selected from among internal references and external pins. The tradeoff between response time and current consumption is configurable by software. Two 6-bit reference dividers allow for a wide range of internally-programmable reference sources. The ACMP can also be used to monitor the supply voltage. An interrupt can be generated when the supply falls below or rises above the programmable threshold.

3.8.3 Digital to Analog Converter (VDAC)

The Digital to Analog Converter (VDAC) can convert a digital value to an analog output voltage. The VDAC is a fully differential, 500 ksp/s, 12-bit converter. The VDAC may be used for a number of different applications such as sensor interfaces or sound output. The VDAC can generate high-resolution analog signals while the MCU is operating at low frequencies and with low total power consumption. Using DMA and a timer, the VDAC can be used to generate waveforms without any CPU intervention. The VDAC is available in all energy modes down to and including EM3.

3.8.4 Liquid Crystal Display Driver (LCD)

The LCD driver is capable of directly driving a segmented LCD. The configurable interface allows for up to 8x36 or 4x40 segments. A voltage boost function enables it to provide the LCD with higher voltage than the supply voltage for the device. A patented charge redistribution driver can reduce the LCD peripheral supply current by up to 40%. In addition, an animation feature can run custom animations on the LCD without any CPU intervention. The LCD driver can also remain active even in Energy Mode 2 and provides a Frame Counter interrupt that can wake-up the device on a regular basis for updating data.

3.9 Power

The EFM32PG26 has an Energy Management Unit (EMU) and efficient integrated regulators to generate internal supply voltages. Only a single external supply voltage is required, from which all internal voltages are created. An optional integrated DC-DC buck regulator can be utilized to further reduce the current consumption. The DC-DC regulator requires one external inductor and one external capacitor.

The EFM32PG26 device family includes support for internal supply voltage scaling, as well as two different power domains groups for peripherals. These enhancements allow for further supply current reductions and lower overall power consumption.

3.9.1 Energy Management Unit (EMU)

The Energy Management Unit manages transitions of energy modes in the device. Each energy mode defines which peripherals and features are available and the amount of current the device consumes. The EMU can also be used to implement system-wide voltage scaling and turn off the power to unused RAM blocks to optimize the energy consumption in the target application. The DC-DC regulator operation is tightly integrated with the EMU.

3.9.2 Voltage Scaling

The EFM32PG26 supports supply voltage scaling for the LDO powering DECOUPLE, with independent selections for EM0 / EM1 and EM2 / EM3. Voltage scaling helps to optimize the energy efficiency of the system by operating at lower voltages when possible. The EM0 / EM1 voltage scaling level defaults to VSCALE2, which allows the core to operate in active mode at full speed. The intermediate level, VSCALE1, allows operation in EM0 and EM1 at up to 40 MHz. The lowest level, VSCALE0, can be used to conserve power further in EM2 and EM3. The EMU will automatically switch the target voltage scaling level when transitioning between energy modes.

3.9.3 DC-DC Converter

The DC-DC buck converter covers a wide range of load currents, providing high efficiency in energy modes EM0, EM1, EM2 and EM3. An on-chip supply-monitor signals when the supply voltage is low to allow bypass of the regulator via programmable software interrupt. It employs soft switching at boot and DCDC regulating-to-bypass transitions to limit the max supply slew-rate and mitigate inrush current.

3.9.4 Power Domains

Peripherals may exist on one of several independent power domains which are powered down to minimize supply current when not in use. Power domains are managed automatically by the EMU.

The lowest-energy power domain is the "high-voltage" power domain (PDHV), which supports extremely low-energy infrastructure and peripherals. Circuits powered from PDHV are always on and available in all energy modes down to EM4.

The next power domain is the low power domain (PD0), which is further divided to power subsets of peripherals. All PD0 power domains are shut down in EM4. Circuits powered from PD0 power domains may be available in EM0, EM1, EM2, and EM3.

Low power domain A (PD0A) is the base power domain for EM2 and EM3 and will always remain on in EM0-EM3. It powers the most commonly-used EM2 and EM3-capable peripherals and infrastructure required to operate in EM2 and EM3. Auxiliary PD0 power domains (PD0B, PD0C, PD0D, PD0E) power additional EM2 and EM3-capable peripherals on demand. If any peripherals on one of the auxiliary power domains is enabled, that power domain will be active in EM2 and EM3. Otherwise, the auxiliary PD0 power domains will be shut down to reduce current.

Note: Power domain PD0E is also turned on when peripherals on PD0B, PD0C, or PD0D are used.

The active power domain (PD1) powers the rest of the device circuitry, including the CPU core and EM0 / EM1 peripherals. PD1 is always powered on in EM0 and EM1. PD1 is always shut down in EM2, EM3, and EM4.

[Table 3.2 Peripheral Power Subdomains on page 17](#) shows the peripherals on the PDHV and PD0x domains. Any peripheral not listed is on PD1.

Table 3.2. Peripheral Power Subdomains

Always On in EM2/EM3		Selectively On in EM2/3			
PDHV ¹	PD0A	PD0B ²	PD0C ²	PD0D ²	PD0E
LFRCO (Non-precision Mode)	SYSRTC	LETIMER0	LFRCO (Precision Calibration Mode)	DEBUG	GPIO
LFXO	FSRCO	IADC0	HFRCOEM23	WDOG0/1	KEYSCAN
BURTC		PCNT0	HFXO	EUSART0	PRS
BURAM		ACMP0/1		I2C0	
ULFRCO		VDAC0/1			

Note:

1. Peripherals on PDHV are also available in EM4.
2. If any of PD0B, PD0C, or PD0D are enabled, PD0E will also be automatically enabled.

3.10 Reset Management Unit (RMU)

The RMU is responsible for handling reset of the EFM32PG26. A wide range of reset sources are available, including several power supply monitors, pin reset, software controlled reset, core lockup reset, and watchdog reset.

3.11 Core, Memory, and Accelerators

3.11.1 Processor Core

The ARM Cortex-M processor includes a 32-bit RISC processor integrating the following features and tasks in the system:

- ARM Cortex-M33 RISC processor achieving 1.50 Dhrystone MIPS/MHz
- ARM TrustZone security technology
- Embedded Trace Macrocell (ETM) for real-time trace and debug
- Up to 3200 kB flash program memory
- Up to 512 kB RAM data memory
- Configuration and event handling of all modules
- 2-pin Serial-Wire debug interface

3.11.2 Memory System Controller (MSC)

The Memory System Controller (MSC) is the program memory unit of the microcontroller. The flash memory is readable and writable from both the Cortex-M33 and LDMA. In addition to the main flash array where Program code is normally written the MSC also provides an Information block where additional information such as special user information or flash-lock bits are stored. There is also a read-only page in the information block containing system and device calibration data. Read and write operations are supported in energy modes EM0 Active and EM1 Sleep.

3.11.3 Linked Direct Memory Access Controller (LDMA)

The Linked Direct Memory Access (LDMA) controller allows the system to perform memory operations independently of software. This reduces both energy consumption and software workload. The LDMA allows operations to be linked together and staged, enabling sophisticated operations to be implemented.

3.11.4 Matrix Vector Processor (MVP)

The Matrix Vector Processor (MVP) is designed to offload the major computationally intensive floating point operations, particularly matrixed complex floating point multiplications and additions. The MVP supports the acceleration of the key Angle-of-Arrival (AoA) MUSIC (MUltiple Signal Classification) algorithm computations, as well as other heavily floating-point computational problems such as Machine Learning (ML) or linear algebra.

3.12 Memory Map

The EFM32PG26 memory map is shown in the figures below. RAM and flash sizes are for the largest memory configuration.

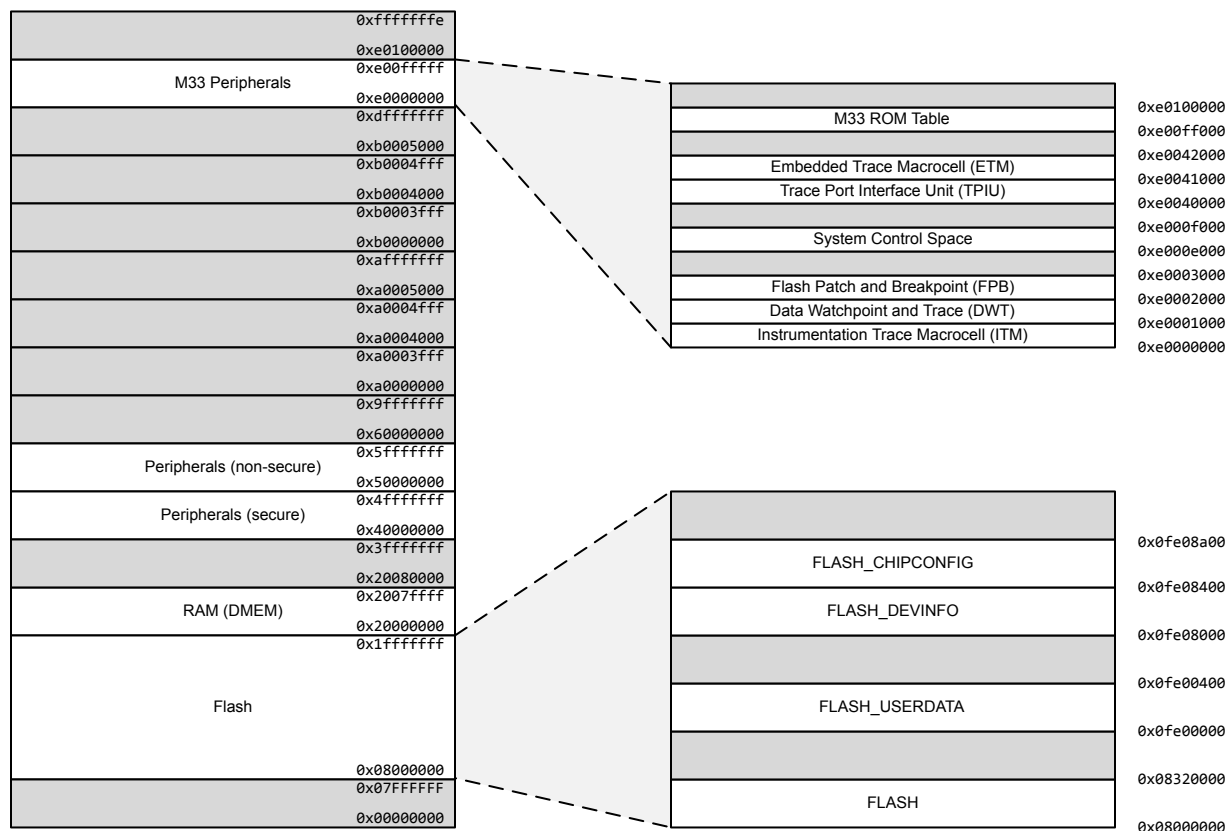

Figure 3.2. EFM32PG26 Memory Map — Core Peripherals and Code Space

3.13 Configuration Summary

The features of the EFM32PG26 are a subset of the feature set described in the device reference manual. The table below describes device specific implementation of the features. Remaining modules support full configuration. Refer to the Energy Modes table in the EFM32PG26 Reference Manual EMU Chapter for a more comprehensive list of energy mode support for all device peripherals.

Table 3.3. Configuration Summary

Module	Lowest Energy Mode	Configuration
I2C0	EM1 - Full functionality EM2/3 ¹ - Functionality limited to receive address recognition	
I2C1	EM1 - Full functionality	
I2C2	EM1 - Full functionality	
I2C3	EM1 - Full functionality	
LETIMER0	EM2/3 ¹	24-bit, 2-channels
TIMER0	EM1	32-bit, 3-channels, +DTI
TIMER1	EM1	32-bit, 3-channels, +DTI
TIMER2	EM1	16-bit, 3-channels, +DTI
TIMER3	EM1	16-bit, 3-channels, +DTI
TIMER4	EM1	16-bit, 3-channels, +DTI
TIMER5	EM1	16-bit, 3-channels, +DTI
TIMER6	EM1	16-bit, 3-channels, +DTI
TIMER7	EM1	16-bit, 3-channels, +DTI
TIMER8	EM1	32-bit, 3-channels, +DTI
TIMER9	EM1	32-bit, 3-channels, +DTI
EUSART0	EM1 - Full high-speed operation, all modes EM2 ¹ - Low-energy UART operation, 9600 Baud EM2/3 ¹ - Low-energy SPI secondary receiver	UART, SPI, IrDA, DALI
EUSART1	EM1	UART, SPI, IrDA, DALI
EUSART2	EM1	UART, SPI, IrDA, DALI
EUSART3	EM1	UART, SPI, IrDA, DALI
USART0	EM1	UART, SPI, IrDA, I2S, SmartCard
USART1	EM1	UART, SPI, IrDA, I2S, SmartCard
USART2	EM1	UART, SPI, IrDA, I2S, SmartCard
Note:		
1. EM2 and EM3 operation is only supported for digital peripheral I/O on Port A and Port B. All GPIO ports support digital peripheral operation in EM0 and EM1.		

4. Electrical Specifications

4.1 Electrical Characteristics

All electrical parameters in all tables are specified under the following conditions, unless stated otherwise:

- Typical values are based on $T_A=25\text{ }^\circ\text{C}$ and all supplies at 3.0 V, by production test and/or technology characterization.
- Radio performance numbers are measured in conducted mode, based on Silicon Laboratories reference designs using output power-specific external RF impedance-matching networks for interfacing to a 50 Ω antenna.
- Minimum and maximum values represent the worst conditions across supply voltage, process variation, and operating temperature, unless stated otherwise.

Due to on-chip circuitry (e.g., diodes), some EFM32PG26 power supply pins have a dependent relationship with one or more other power supply pins. These internal relationships between the external voltages applied to the various EFM32PG26 supply pins are defined below. Exceeding the below constraints can result in damage to the device and/or increased current draw.

- VREGVDD and DVDD
 - In systems using the DCDC converter, DVDD (the buck converter output) should not be driven externally and VREGVDD (the buck converter input) must be greater than DVDD ($VREGVDD \geq DVDD$)
 - In systems not using the DCDC converter, DVDD must be shorted to VREGVDD on the PCB ($VREGVDD = DVDD$)
- AVDD, IOVDD: No dependency with each other or any other supply pin. Additional leakage may occur if DVDD remains unpowered with power applied to these supplies.
- $DVDD \geq DECOUPLE$
- $PAVDD \geq RFVDD$

4.2 Absolute Maximum Ratings

Stresses beyond those listed below may cause permanent damage to the device. This is a stress rating only and functional operation of the devices at those or any other conditions beyond those indicated in the operation listings of this specification is not implied. Exposure to maximum rating conditions for extended periods may affect device reliability. For more information on the available quality and reliability data, see the Quality and Reliability Monitor Report at <http://www.silabs.com/support/quality/pages/default.aspx>.

Table 4.1. Absolute Maximum Ratings

Parameter	Symbol	Test Condition	Min	Typ	Max	Unit
Storage temperature range	T _{STG}		-50	—	+150	°C
Voltage on any supply pin ¹	V _{DDMAX}		-0.3	—	3.8	V
Junction temperature	T _{JMAX}	-I grade	—	—	+125	°C
Voltage ramp rate on any supply pin	V _{DDRAMPMAX}		—	—	1.0	V / μ s
Voltage on HFXO pins	V _{HFXOPIN}		-0.3	—	1.2	V
DC voltage on any GPIO pin ²	V _{DIGPIN}		-0.3	—	V _{IOVDD} + 0.3	V
DC voltage on RESETn pin ³	V _{RESETn}		-0.3	—	3.8	V
Total current into VDD power lines	I _{VDDMAX}	Source	—	—	200	mA
Total current into VSS ground lines	I _{VSSMAX}	Sink	—	—	200	mA
Current per I/O pin	I _{IOMAX}	Sink	—	—	50	mA
		Source	—	—	50	mA
Current for all I/O pins	I _{IOALLMAX}	Sink	—	—	200	mA
		Source	—	—	200	mA

Note:

1. The maximum supply voltage on VREGVDD is limited under certain conditions when using the DC-DC. See the DC-DC specifications for more details.
2. When operating as an LCD driver, the output voltage on a GPIO may safely exceed this specification. The pin output voltage may be up to 3.8 V in this case.
3. The RESETn pin has a pull-up device to the DVDD supply. For minimum leakage, RESETn should not exceed the voltage at DVDD.

4.3 General Operating Conditions

Table 4.2. General Operating Conditions

Parameter	Symbol	Test Condition	Min	Typ	Max	Unit
Operating ambient temperature range	T_A	-I temperature grade ¹	-40	—	+125	° C
DVDD supply voltage	V_{DVDD}	EM0/1	1.71	3.0	3.8	V
		EM2/3/4 ²	1.71	3.0	3.8	V
AVDD supply voltage	V_{AVDD}	AVDDBODEN=0 ³	1.71	3.0	3.8	V
IOVDDx operating supply voltage (All IOVDD pins)	V_{IOVDDx}	IOVDDxBODEN=0 ³	1.71	3.0	3.8	V
VREGVDD operating supply voltage	$V_{VREGVDD}$	DC-DC in regulation ⁴	2.2	3.0	3.8	V
		DC-DC in bypass 60 mA load	1.8	3.0	3.8	V
		DC-DC in bypass 120 mA load	1.8	3.0	3.8	V
		DC-DC not in use. DVDD externally shorted to VREGVDD	1.71	3.0	3.8	V
DECOUPLE output capacitor ⁵	$C_{DECOUPLE}$	1.0 μ F \pm 10% X8L capacitor used for performance characterization.	1.0	—	2.75	μ F
HCLK and SYSCLK frequency	f_{HCLK}	VSCALE2, MODE = WS1	—	—	80	MHz
		VSCALE2, MODE = WS0	—	—	40	MHz
		VSCALE1, MODE = WS1	—	—	40	MHz
		VSCALE1, MODE = WS0	—	—	20	MHz
PCLK frequency	f_{PCLK}	VSCALE2 or VSCALE1	—	—	40	MHz
EM01 Group A clock frequency	$f_{EM01GRPACLK}$	VSCALE2	—	—	80	MHz
		VSCALE1	—	—	40	MHz
EM01 Group C clock frequency	$f_{EM01GRPCCLK}$	VSCALE2	—	—	80	MHz
		VSCALE1	—	—	40	MHz
External Clock Input	f_{CLKIN}	VSCALE2 or VSCALE1, IOVDD \geq 2.7 V	—	—	40	MHz
DPLL Reference Clock	$f_{DPLLREFCLK}$	VSCALE2 or VSCALE1	—	—	40	MHz

Note:

1. The device may operate continuously at the maximum allowable ambient T_A rating as long as the absolute maximum T_{JMAX} is not exceeded. For an application with significant power dissipation, the allowable T_A may be lower than the maximum T_A rating. $T_A = T_{JMAX} - (THETA_{JA} \times PowerDissipation)$. Refer to the Absolute Maximum Ratings table and the Thermal Characteristics table for T_{JMAX} and $THETA_{JA}$.
2. The DVDD supply is monitored by the DVDD BOD in EM0/1 and the LE DVDD BOD in EM2/3/4.
3. The AVDD and IOVDD enable bits are in the EMU_BOD3SENSE register. These BODs are disabled on reset.
4. The maximum supply voltage on VREGVDD is limited under certain conditions when using the DC-DC. See the DC-DC specifications for more details.
5. Murata GCM21BL81C105KA58L used for performance characterization. Actual capacitor values can be significantly de-rated from their specified nominal value by the rated tolerance, as well as the application's AC voltage, DC bias, and temperature. The minimum capacitance counting all error sources should be no less than 0.6 μ F.

4.4 DC-DC Converter

Test conditions: $L_{DCDC} = 2.2 \mu\text{H}$ (Murata DFE2HCAH2R2MJ0), $C_{DCDC} = 4.7 \mu\text{F}$ (TDK CGA5L3X8R1C475K160AB), $V_{VREGVDD} = 3.0 \text{ V}$, $V_{OUT} = 1.8 \text{ V}$, I_{PKVAL} in EM0/1 modes is set to 150 mA, and in EM2/3 modes is set to 90 mA, unless otherwise indicated.

Table 4.3. DC-DC Converter

Parameter	Symbol	Test Condition	Min	Typ	Max	Unit
Input voltage range at VREGVDD pin	$V_{VREGVDD}$	PFMX mode, DCDC in regulation, $I_{LOAD} = I_{LOAD \text{ MAX}}$, EM0/EM1 mode	2.2	—	3.8	V
		PFM mode, DCDC in regulation, $I_{LOAD} = 60 \text{ mA}$, EM0/EM1 mode	2.2	—	3.8	V
		PFM mode, DCDC in regulation, $I_{LOAD} = 5 \text{ mA}$, EM0/EM1 or EM2/EM3 mode	1.8	—	3.8	V
		Bypass Mode, $I_{LOAD} \leq 60 \text{ mA}$	1.8	—	3.8	V
		Bypass Mode, $I_{LOAD} \leq 120 \text{ mA}$	1.9	—	3.8	V
Regulated output voltage	V_{OUT}		—	1.8	—	V
Regulation DC accuracy	ACC_{DC}	PFM/PFMX mode, $V_{VREGVDD} \geq 2.2 \text{ V}$, Steady state in EM0/EM1 mode or EM2/EM3 mode	-2.5	—	4.0	%
Regulation total accuracy	ACC_{TOT}	PFM/PFMX mode, All error sources (including DC errors, overshoot, undershoot)	-5	—	7	%
Steady-state output ripple	V_R	PFM/PFMX mode, $I_{LOAD} = 20 \text{ mA}$ in EM0/EM1 mode	—	12	—	mVpp
DC line regulation	V_{REG}	PFM mode, $I_{LOAD} = 60 \text{ mA}$ in EM0/EM1 mode, $V_{VREGVDD} \geq 2.2 \text{ V}$	—	-2.6	—	mV/V
		PFMX mode, $I_{LOAD} = I_{LOAD \text{ MAX}}$ in EM0/EM1 mode, $V_{VREGVDD} \geq 2.2 \text{ V}$	—	-2.6	—	mV/V
Efficiency	EFF	PFM mode, Load current between 100 μA and 60 mA in EM0/EM1 mode	—	90	—	%
		PFM mode, Load current between 10 μA and 5 mA in EM2/EM3 mode	—	89	—	%
DC load regulation	I_{REG}	PFM/PFMX mode, Load current between 100 μA and $I_{LOAD \text{ MAX}}$ in EM0/EM1 mode	—	-0.08	—	mV/mA
		PFM mode, Load current between 100 μA and 60 mA in EM0/EM1 mode	—	-0.08	—	mV/mA

Parameter	Symbol	Test Condition	Min	Typ	Max	Unit
Output load current ¹	I _{LOAD}	PFM mode, EM0/EM1 mode, DCDC in regulation, DCDC_EM01CTRL0.IPKVAL = 9	—	—	60	mA
		PFMX mode, EM0/EM1 mode, DCDC in regulation, DCDC_PFMXCTRL.IPKVAL = 12	—	—	120	mA
		PFM mode, EM2/EM3 mode, DCDC in regulation	—	—	5	mA
		Bypass mode, 1.8 V ≤ V _{VREGVDD} ≤ 3.8 V	—	—	60	mA
		Bypass mode, 1.9 V ≤ V _{VREGVDD} ≤ 3.8 V	—	—	120	mA
Nominal output capacitor	C _{DCDC}	4.7 μF ± 10% X7R capacitor used for performance characterization ²	—	4.7	10	μF
Nominal inductor	L _{DCDC}	± 20% tolerance	—	2.2	—	μH
Nominal input capacitor	C _{IN}		C _{DCDC}	—	—	μF
Resistance in bypass mode	R _{BYP}	Bypass switch from VREGVDD to DVDD, V _{VREGVDD} = 1.8 V	—	0.45	0.69	Ω
		Powertrain PFET switch from VREGVDD to VREGSW, V _{VREGVDD} = 1.8 V	—	0.6	0.9	Ω
Supply monitor threshold programming range	V _{CMP_RNG}	Programmable in 0.1 V steps	2	—	2.3	V
Supply monitor threshold accuracy	V _{CMP_ACC}	Supply falling edge trip point	-5	—	5	%
Supply monitor threshold hysteresis	V _{CMP_HYST}	Positive hysteresis on the supply rising edge referred to the falling edge trip point	—	4	—	%
Supply monitor response time	t _{CMP_DELAY}	Supply falling edge at -100 mV / μs	—	0.6	—	μs

Note:

- I_{LOAD} is the total current sourced by the DCDC, including on-chip and off-chip circuits powered from the DVDD supply rail.
- Actual capacitor values can be significantly de-rated from their specified nominal value by the rated tolerance, as well as the application's AC voltage, DC bias, and temperature. The minimum capacitance counting all error sources should be no less than 3.6 μF.

4.4.1 DC-DC Maximum Load Current

The DC-DC converter can operate in one of two states in EM0/1:

- PFM mode only: Supports a maximum DC-DC load current of 60 mA
- PFMX mode: Supports a maximum DC-DC load current of 120 mA

4.4.2 PFM Mode

PFM mode is enabled by clearing the DCDC->CTRL.PFMXTREQ bit. In PFM mode, the maximum inductor current in EM0/1 is determined by the DCDC->EM01CTRL0.IPKVAL.

In PFM mode, the DC-DC converter may be operated below 2.2 V in EM0/1 with some reduction in maximum load current, as shown below.

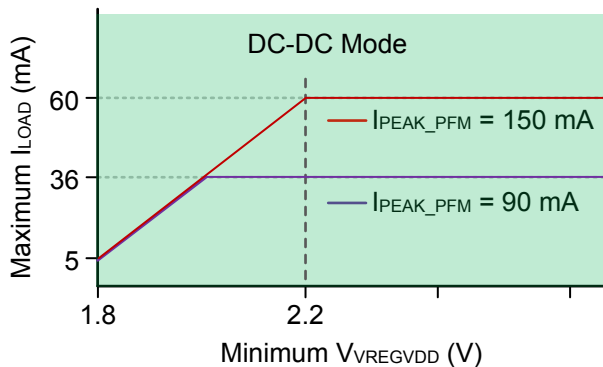

Figure 4.1. Maximum Load Current vs. Minimum Input Voltage (PFM Mode)

4.4.3 PFMX Mode

PFMX mode is enabled by clearing the DCDC->CTRL.PFMXTREQ bit. In PFMX mode, the maximum inductor current in EM0/1 is determined by the DCDC->PFMXCTRL.IPKVAL.

In PFMX mode, the DC-DC converter may not be used below 2.2 V as shown below. Below 2.2 V, Bypass Mode should be enabled, which supports a maximum load of 60 mA down to 1.8 V (or 120 mA down to 1.9 V).

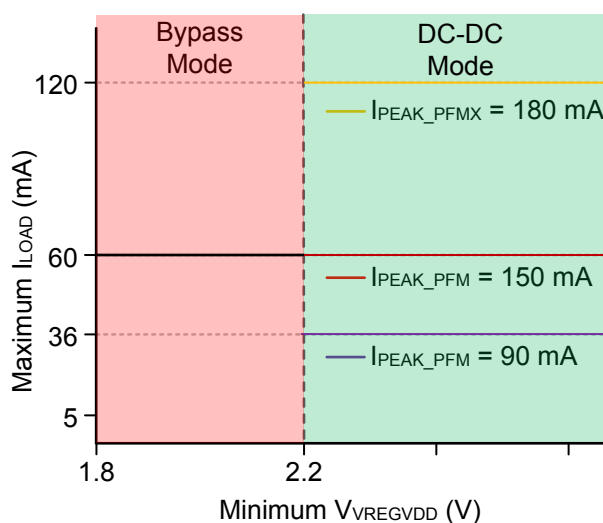

Figure 4.2. Maximum Load Current vs. Minimum Input Voltage (PFMX Mode)

4.5 Thermal Characteristics

Table 4.4. Thermal Characteristics

Package	Board	Parameter	Symbol	Test Condition	Value	Unit
48QFN (6x6mm)	JEDEC - High Thermal Cond. (2s2p) ¹	Thermal Resistance, Junction to Ambient	Θ_{JA}	Still Air	21.8	°C/W
		Thermal Resistance, Junction to Board	Θ_{JB}		6.6	°C/W
		Thermal Resistance, Junction to Top Center	Ψ_{JT}		0.19	°C/W
		Thermal Resistance, Junction to Board	Ψ_{JB}		11.3	°C/W
68QFN (8x8mm)	JEDEC - High Thermal Cond. (2s2p) ²	Thermal Resistance, Junction to Ambient	Θ_{JA}	Still Air	19.6	°C/W
		Thermal Resistance, Junction to Board	Θ_{JB}		6	°C/W
		Thermal Resistance, Junction to Top Center	Ψ_{JT}		0.68	°C/W
		Thermal Resistance, Junction to Board	Ψ_{JB}		9.6	°C/W
136BGA (8x8mm)	JEDEC - High Thermal Cond. (2s2p) ³	Thermal Resistance, Junction to Ambient	Θ_{JA}	Still Air	19.3	°C/W
		Thermal Resistance, Junction to Top Center	Ψ_{JT}		0.10	°C/W
		Thermal Resistance, Junction to Board	Ψ_{JB}		5.7	°C/W

Note:

1. Based on 4 layer PCB with dimension 3" x 4.5", PCB Thickness of 1.6 mm, per JEDEC. PCB Center Land with 9 Via to top internal plane of PCB.
2. Based on 4 layer PCB with dimension 3" x 4.5", PCB Thickness of 1.6 mm, per JEDEC. PCB Center Land with 25 Via to top internal plane of PCB.
3. Based on 4 layer PCB using 48 thermal vias. PCB stackup and thickness as per "Low Effective Thermal Conductivity Test Board for Leaded Surface Mount Packages, JESD51-3, Aug 1996" and "High Effective Thermal Conductivity Test Board for Leaded Surface Mount Packages, JESD51-7".

4.6 Current Consumption

4.6.1 MCU Current Consumption using DC-DC at 3.0 V Input

Unless otherwise indicated, typical conditions are: VREGVDD = 3.0 V. AVDD = DVDD = IOVDD = 1.8 V from DC-DC. Voltage scaling level = VSCALE1. T_A = 25 °C. Minimum and maximum values in this table represent the worst conditions across process variation at T_A = 25 °C.

Table 4.5. MCU Current Consumption using DC-DC at 3.0 V Input

Parameter	Symbol	Test Condition	Min	Typ	Max	Unit
Current consumption in EM0 mode with all peripherals disabled	I _{ACTIVE}	80 MHz HFRCO, CPU running Prime from flash, VSCALE2	—	41.8	—	μA/MHz
		80 MHz HFRCO, CPU running while loop from flash, VSCALE2	—	42.8	—	μA/MHz
		80 MHz HFRCO, CPU running CoreMark loop from flash, VSCALE2	—	59.2	—	μA/MHz
		39 MHz crystal, CPU running Prime from flash	—	54.0	—	μA/MHz
		39 MHz crystal, CPU running while loop from flash	—	53.9	—	μA/MHz
		39 MHz crystal, CPU running CoreMark loop from flash	—	69.9	—	μA/MHz
		38 MHz HFRCO, CPU running while loop from flash	—	50.0	—	μA/MHz
		26 MHz HFRCO, CPU running while loop from flash	—	60.4	—	μA/MHz
		16 MHz HFRCO, CPU running while loop from flash	—	81.5	—	μA/MHz
		1 MHz HFRCO, CPU running while loop from flash	—	899.4	—	μA/MHz
Current consumption in EM1 mode with all peripherals disabled	I _{EM1}	80 MHz HFRCO, VSCALE2	—	30.0	—	μA/MHz
		39 MHz crystal	—	41.5	—	μA/MHz
		38 MHz HFRCO	—	37.7	—	μA/MHz
		26 MHz HFRCO	—	48.0	—	μA/MHz
		16 MHz HFRCO	—	69.3	—	μA/MHz
		1 MHz HFRCO	—	888.3	—	μA/MHz

Parameter	Symbol	Test Condition	Min	Typ	Max	Unit
Current consumption in EM2 mode, VSCALE0	I _{EM2_VS}	512 kB RAM, RTC running from LFXO ¹	—	5.0	—	μA
		512 kB RAM, RTC running from LFRCO ¹	—	5.0	—	μA
		256 kB RAM, RTC running from LFXO ¹	—	3.2	—	μA
		256 kB RAM, RTC running from LFRCO ¹	—	3.2	—	μA
		16 kB RAM, RTC running from LFXO ¹	—	1.4	—	μA
		16 kB RAM, RTC running from LFRCO ¹	—	1.4	—	μA
		16 kB RAM, RTC running from LFRCO in precision mode ¹	—	2.15	—	μA
Current consumption in EM3 mode, VSCALE0	I _{EM3_VS}	512 kB RAM, RTC running from ULFRCO. CPU cache, EM0/1 peripheral states retained. ¹	—	4.7	—	μA
		256 kB RAM, RTC running from ULFRCO. CPU cache, EM0/1 peripheral states retained. ¹	—	2.9	—	μA
		16 kB RAM, RTC running from ULFRCO. CPU cache, EM0/1 peripheral states retained. ¹	—	1.2	—	μA
Change in current consumption if CPU cached unre- tained in EM2 or EM3	I _{EM23_CPUCACHE}		—	-0.12	—	μA
Change in current consumption if EM0/1 peripheral states unretained in EM2 or EM3	I _{EM23_STATERET}		—	-0.03	—	μA
Change in current consumption for retained RAM bank in EM2 or EM3	I _{EM23_RAM}	Per 16 kB RAM bank	—	0.12	—	μA
Additional current in EM2 or EM3 when any peripheral in PDOB is enabled ²	I _{PD0B_VS}		—	1.29	—	μA
Additional current in EM2 or EM3 when any peripheral in PDOC is enabled ²	I _{PD0C_VS}		—	0.44	—	μA
Additional current in EM2 or EM3 when any peripheral in PDOD is enabled ²	I _{PD0D_VS}		—	1.61	—	μA
Additional current in EM2 or EM3 when any peripheral in PDOE is enabled ²	I _{PD0E_VS}		—	0.18	—	μA
Current consumption in EM4 mode ³	I _{EM4}	No BURTC, no LF oscillator	—	0.23	—	μA
		BURTC with LFXO	—	0.66	—	μA

Parameter	Symbol	Test Condition	Min	Typ	Max	Unit
-----------	--------	----------------	-----	-----	-----	------

Note:

1. CPU cache retained, EM0/1 peripheral states retained
2. Extra current consumed by power domain. Does not include current associated with the enabled peripherals. See [3.9.4 Power Domains](#) for a list of the peripherals in each power domain. Note that if the PD0B, PD0C, or PD0D domains are enabled, PD0E will also automatically be enabled.
3. Note that the DCDC will be disabled in EM4.

4.6.2 MCU Current Consumption at 3.0 V

Unless otherwise indicated, typical conditions are: AVDD = DVDD = IOVDD = VREGVDD = 3.0 V. DC-DC not used. Voltage scaling level = VSCALE1. T_A = 25 °C. Minimum and maximum values in this table represent the worst conditions across process variation at T_A = 25 °C.

Table 4.6. MCU Current Consumption at 3.0 V

Parameter	Symbol	Test Condition	Min	Typ	Max	Unit
Current consumption in EM0 mode with all peripherals disabled	I _{ACTIVE}	80 MHz HFRCO, CPU running Prime from flash, VSCALE2	—	58.1	—	μA/MHz
		80 MHz HFRCO, CPU running while loop from flash, VSCALE2	—	59.3	—	μA/MHz
		39 MHz crystal, CPU running Prime from flash	—	72.7	—	μA/MHz
		39 MHz crystal, CPU running while loop from flash	—	75.0	—	μA/MHz
		39 MHz crystal, CPU running CoreMark loop from flash	—	97.1	—	μA/MHz
		38 MHz HFRCO, CPU running while loop from flash	—	69.6	180	μA/MHz
		26 MHz HFRCO, CPU running while loop from flash	—	84.1	—	μA/MHz
		16 MHz HFRCO, CPU running while loop from flash	—	113.6	—	μA/MHz
		1 MHz HFRCO, CPU running while loop from flash	—	1251	5400	μA/MHz
Current consumption in EM1 mode with all peripherals disabled	I _{EM1}	80 MHz HFRCO, VSCALE2	—	41.7	—	μA/MHz
		39 MHz crystal	—	57.7	—	μA/MHz
		38 MHz HFRCO	—	52.3	162	μA/MHz
		26 MHz HFRCO	—	66.8	—	μA/MHz
		16 MHz HFRCO	—	96.3	—	μA/MHz
		1 MHz HFRCO	—	1232	5400	μA/MHz
Current consumption in EM2 mode, VSCALE0	I _{EM2_VS}	512 kB RAM, RTC running from LFXO ¹	—	7.0	—	μA
		512 kB RAM, RTC running from LFRCO ¹	—	7.0	20.5	μA
		256 kB RAM, RTC running from LFXO ¹	—	4.4	—	μA
		256 kB RAM, RTC running from LFRCO ¹	—	4.4	—	μA
		16 kB RAM, RTC running from LFXO ¹	—	2.0	—	μA
		16 kB RAM, RTC running from LFRCO ¹	—	2.0	—	μA
		16 kB RAM, RTC running from LFRCO in precision mode ¹	—	2.6	—	μA

Parameter	Symbol	Test Condition	Min	Typ	Max	Unit
Current consumption in EM3 mode, VSCALE0	I _{EM3_VS}	512 kB RAM, RTC running from ULFRCO. CPU cache, EM0/1 peripheral states retained. ¹	—	6.7	—	μA
		256 kB RAM, RTC running from ULFRCO. CPU cache, EM0/1 peripheral states retained. ¹	—	4.1	—	μA
		16 kB RAM, RTC running from ULFRCO. CPU cache, EM0/1 peripheral states retained. ¹	—	1.6	3.8	μA
Change in current consumption if CPU cached unretrained in EM2 or EM3	I _{EM23_CPUCACHE}		—	-0.1	—	μA
Change in current consumption if EM0/1 peripheral states unretrained in EM2 or EM3	I _{EM23_STATERET}		—	-0.03	—	μA
Change in current consumption for retained RAM bank in EM2 or EM3	I _{EM23_RAM}	Per 16 kB RAM bank	—	0.17	—	μA
Additional current in EM2 or EM3 when any peripheral in PD0B is enabled ²	I _{PD0B_VS}		—	1.82	—	μA
Additional current in EM2 or EM3 when any peripheral in PD0C is enabled ²	I _{PD0C_VS}		—	0.6	—	μA
Additional current in EM2 or EM3 when any peripheral in PD0D is enabled ²	I _{PD0D_VS}		—	2.28	—	μA
Additional current in EM2 or EM3 when any peripheral in PD0E is enabled ²	I _{PD0E_VS}		—	0.25	—	μA
Current consumption in EM4 mode	I _{EM4}	No BURTC, no LF oscillator	—	0.23	0.65	μA
		BURTC with LFXO	—	0.66	—	μA
Current consumption during reset	I _{RST}	Hard pin reset held	—	448	—	μA

Note:

1. CPU cache retained, EM0/1 peripheral states retained
2. Extra current consumed by power domain. Does not include current associated with the enabled peripherals. See [3.9.4 Power Domains](#) for a list of the peripherals in each power domain. Note that if the PD0B, PD0C, or PD0D domains are enabled, PD0E will also automatically be enabled.

4.6.3 MCU Current Consumption at 1.8 V

Unless otherwise indicated, typical conditions are: AVDD = DVDD = IOVDD = VREGVDD = 1.8 V. DC-DC not used. Voltage scaling level = VSCALE1. T_A = 25 °C. Minimum and maximum values in this table represent the worst conditions across process variation at T_A = 25 °C.

Table 4.7. MCU Current Consumption at 1.8 V

Parameter	Symbol	Test Condition	Min	Typ	Max	Unit
Current consumption in EM0 mode with all peripherals disabled	I _{ACTIVE}	80 MHz HFRCO, CPU running Prime from flash, VSCALE2	—	57.9	—	µA/MHz
		80 MHz HFRCO, CPU running while loop from flash, VSCALE2	—	59.1	—	µA/MHz
		39 MHz crystal, CPU running Prime from flash	—	73.3	—	µA/MHz
		39 MHz crystal, CPU running while loop from flash	—	74.5	—	µA/MHz
		39 MHz crystal, CPU running CoreMark loop from flash	—	96.6	—	µA/MHz
		38 MHz HFRCO, CPU running while loop from flash	—	69.2	—	µA/MHz
		26 MHz HFRCO, CPU running while loop from flash	—	83.6	—	µA/MHz
		16 MHz HFRCO, CPU running while loop from flash	—	112.8	—	µA/MHz
		1 MHz HFRCO, CPU running while loop from flash	—	1239	—	µA/MHz
Current consumption in EM1 mode with all peripherals disabled	I _{EM1}	80 MHz HFRCO, VSCALE2	—	41.5	—	µA/MHz
		39 MHz crystal	—	57.3	—	µA/MHz
		38 MHz HFRCO	—	52.0	—	µA/MHz
		26 MHz HFRCO	—	66.3	—	µA/MHz
		16 MHz HFRCO	—	95.6	—	µA/MHz
		1 MHz HFRCO	—	1221	—	µA/MHz
Current consumption in EM2 mode, VSCALE0	I _{EM2_VS}	512 kB RAM, RTC running from LFXO ¹	—	6.9	—	µA
		512 kB RAM, RTC running from LFRCO ¹	—	6.9	—	µA
		256 kB RAM, RTC running from LFXO ¹	—	4.3	—	µA
		256 kB RAM, RTC running from LFRCO ¹	—	4.3	—	µA
		16 kB RAM, RTC running from LFXO ¹	—	1.9	—	µA
		16 kB RAM, RTC running from LFRCO ¹	—	1.9	—	µA
		16 kB RAM, RTC running from LFRCO in precision mode ¹	—	2.9	—	µA

Parameter	Symbol	Test Condition	Min	Typ	Max	Unit
Current consumption in EM3 mode, VSCALE0	I _{EM3_VS}	512 kB RAM, RTC running from ULFRCO. CPU cache, EM0/1 peripheral states retained. ¹	—	6.6	—	μA
		256 kB RAM, RTC running from ULFRCO. CPU cache, EM0/1 peripheral states retained. ¹	—	4.0	—	μA
		16 kB RAM, RTC running from ULFRCO. CPU cache, EM0/1 peripheral states retained. ¹	—	1.5	—	μA
Change in current consumption if CPU cached unre- tained in EM2 or EM3	I _{EM23_CPUCACHE}		—	-0.09	—	μA
Change in current consumption if EM0/1 peripheral states unre- tained in EM2 or EM3	I _{EM23_STATERET}		—	-0.02	—	μA
Change in current consumption for retained RAM bank in EM2 or EM3	I _{EM23_RAM}	Per 16 kB RAM bank	—	0.16	—	μA
Additional current in EM2 or EM3 when any peripheral in PD0B is enabled ²	I _{PD0B_VS}		—	1.83	—	μA
Additional current in EM2 or EM3 when any peripheral in PD0C is enabled ²	I _{PD0C_VS}		—	0.6	—	μA
Additional current in EM2 or EM3 when any peripheral in PD0D is enabled ²	I _{PD0D_VS}		—	2.28	—	μA
Additional current in EM2 or EM3 when any peripheral in PD0E is enabled ²	I _{PD0E_VS}		—	0.24	—	μA
Current consumption in EM4 mode	I _{EM4}	No BURTC, no LF oscillator	—	0.17	—	μA
		BURTC with LFXO	—	0.55	—	μA
Current consumption during reset	I _{RST}	Hard pin reset held	—	383	—	μA

Note:

1. CPU cache retained, EM0/1 peripheral states retained
2. Extra current consumed by power domain. Does not include current associated with the enabled peripherals. See [3.9.4 Power Domains](#) for a list of the peripherals in each power domain. Note that if the PD0B, PD0C, or PD0D domains are enabled, PD0E will also automatically be enabled.

4.7 Flash Characteristics

If spec conditions specify " $T_A = 25\text{ }^\circ\text{C}$ ", then minimum and/or maximum values for that spec represent the worst conditions across process variation at $T_A = 25\text{ }^\circ\text{C}$. Otherwise, minimum and maximum values represent the worst conditions across supply voltage, process variation, and operating temperature.

Table 4.8. Flash Characteristics

Parameter	Symbol	Test Condition	Min	Typ	Max	Unit
Flash Supply voltage during write or erase	V_{FLASH}		1.71	—	3.8	V
Flash data retention ¹	RET_{FLASH}	$T_A \leq 125\text{ }^\circ\text{C}$	10	—	—	years
Flash erase cycles before failure ¹	EC_{FLASH}	$T_A \leq 125\text{ }^\circ\text{C}$	10,000	—	—	cycles
Program Time	t_{PROG}	$T_A = 25\text{ }^\circ\text{C}$, one word (32-bits)	41.3	43.4	45.7	μs
		$T_A = 25\text{ }^\circ\text{C}$, average per word over 128 words	10.2	10.9	11.3	μs
Page Erase Time ²	t_{PERASE}	$T_A = 25\text{ }^\circ\text{C}$	10.5	12.9	15.2	ms
Mass Erase Time ^{3 4}	t_{MERASE}	$T_A = 25\text{ }^\circ\text{C}$, 3200kB	297.1	312.4	327.9	ms
Program Current	I_{WRITE}		—	—	4.0	mA
Page Erase Current	I_{PERASE}	Page Erase	—	—	2.0	mA
Mass Erase Current	I_{MERASE}	Mass Erase	—	—	2.0	mA

Note:

- Flash data retention information is published in the Quarterly Quality and Reliability Report.
- Page Erase time is measured from setting the ERASEPAGE bit in the MSC_WRITECMD register until the BUSY bit in the MSC-STATUS register is cleared to 0. Internal set-up and hold times are included.
- Mass Erase is issued by the CPU and erases all of User space.
- Mass Erase time is measured from setting the ERASEMAIN0 bit in the MSC_WRITECMD register until the BUSY bit in the MSC-STATUS register is cleared to 0. Internal set-up and hold times are included.

4.8 Energy Mode Wake-up and Entry Times

Unless otherwise specified, these times are measured using the HFRCO at 19 MHz.

Table 4.9. Energy Mode Wake-up and Entry Times

Parameter	Symbol	Test Condition	Min	Typ	Max	Unit
Wake-up Time from EM1	t_{EM1_WU}	Code execution from flash	—	3	—	HCLKs
		Code execution from RAM	—	1.4	—	μ s
Wake-up Time from EM2	t_{EM2_WU}	Code execution from flash, No Voltage Scaling	—	13.1	—	μ s
		Code execution from RAM, No Voltage Scaling	—	5.2	—	μ s
		Voltage scaling up one level ¹	—	37.8	—	μ s
		Voltage scaling up two levels ²	—	50.0	—	μ s
Wake-up Time from EM3	t_{EM3_WU}	Code execution from flash, No Voltage Scaling	—	13.1	—	μ s
		Code execution from RAM, No Voltage Scaling	—	5.2	—	μ s
		Voltage scaling up one level ¹	—	37.8	—	μ s
		Voltage scaling up two levels ²	—	50.0	—	μ s
Wake-up Time from EM4	t_{EM4_WU}	Code execution from flash	—	17.0	—	ms
Entry time to EM1	t_{EM1_ENT}	Code execution from flash	—	1.2	—	μ s
Entry time to EM2	t_{EM2_ENT}	Code execution from flash	—	5.9	—	μ s
Entry time to EM3	t_{EM3_ENT}	Code execution from flash	—	5.9	—	μ s
Entry time to EM4	t_{EM4_ENT}	Code execution from flash	—	10.9	—	μ s
Voltage scaling time in EM0 ³	t_{SCALE}	Up from VSCALE1 to VSCALE2	—	32	—	μ s
		Down from VSCALE2 to VSCALE1	—	172	—	μ s

Note:

1. Voltage scaling one level is between VSCALE0 and VSCALE1 or between VSCALE1 and VSCALE2.
2. Voltage scaling two levels is between VSCALE0 and VSCALE2.
3. During voltage scaling in EM0, RAM is inaccessible and processor will be halted until complete.

4.9 Oscillators

4.9.1 High Frequency Crystal Oscillator (HFXO)

Unless otherwise indicated, typical conditions are: AVDD = DVDD = 3.0 V. T_A = 25 °C. Minimum and maximum values in this table represent the worst conditions across process variation, operating supply voltage range, and operating temperature range.

Table 4.10. High Frequency Crystal Oscillator (HFXO)

Parameter	Symbol	Test Condition	Min	Typ	Max	Unit
Crystal Frequency	F _{HFXO}		38.0	39.0	40.0	MHz
Supported crystal maximum equivalent series resistance (ESR)	ESR _{HFXO}	Crystal Frequency = 39.0 MHz	—	—	60	Ω
Supported range of crystal load capacitance ¹	C _{L_HFXO}	39.0 MHz, ESR = 40 Ω ²	—	10	—	pF
Supply Current	I _{HFXO}	39.0 MHz	—	565	—	μA
Startup Time ³	T _{STARTUP}	39.0 MHz, ESR = 40 Ω, C _L = 10 pF	—	188	—	μs
On-chip tuning cap step size ⁴	SS _{HFXO}		—	0.04	—	pF

Note:

1. Total load capacitance as seen by the crystal.
2. RF performance characteristics have been determined using crystals with an ESR of 40 Ω and C_L of 10 pF.
3. Startup time does not include time implemented by programmable TIMEOUTSTEADY delay.
4. The tuning step size is the effective step size when incrementing both of the tuning capacitors by one count. The step size for the each of the individual tuning capacitors is twice this value.

4.9.2 Low Frequency Crystal Oscillator (LFXO)

Table 4.11. Low Frequency Crystal Oscillator (LFXO)

Parameter	Symbol	Test Condition	Min	Typ	Max	Unit
Crystal Frequency	F_{LFXO}		—	32.768	—	kHz
Supported Crystal equivalent series resistance (ESR)	ESR_{LFXO}	GAIN = 0	—	—	80	k Ω
		GAIN = 1 to 3	—	—	100	k Ω
Supported range of crystal load capacitance ¹	C_{L_LFXO}	GAIN = 0	4	—	6	pF
		GAIN = 1	6	—	10	pF
		GAIN = 2 (see note ²)	10	—	12.5	pF
		GAIN = 3 (see note ²)	12.5	—	18	pF
Current consumption	I_{CL12p5}	ESR = 70 k Ω , C_L = 12.5 pF, GAIN ³ = 2, AGC ⁴ = 1	—	294	—	nA
Startup Time	$T_{STARTUP}$	ESR = 70 k Ω , C_L = 7 pF, GAIN ³ = 1, AGC ⁴ = 1	—	52	—	ms
On-chip tuning cap step size	SS_{LFXO}		—	0.26	—	pF
On-chip tuning capacitor value at minimum setting ⁵	C_{LFXO_MIN}	CAPTUNE = 0	—	5.2	—	pF
On-chip tuning capacitor value at maximum setting ⁵	C_{LFXO_MAX}	CAPTUNE = 0x4F	—	26.2	—	pF

Note:

1. Total load capacitance seen by the crystal
2. Crystals with a load capacitance of greater than 12 pF require external load capacitors.
3. In LFXO_CAL Register
4. In LFXO_CFG Register
5. The effective load capacitance seen by the crystal will be $C_{LFXO}/2$. This is because each XTAL pin has a tuning cap and the two caps will be seen in series by the crystal

4.9.3 High Frequency RC Oscillator (HFRCO)

Unless otherwise indicated, typical conditions are: AVDD = DVDD = 3.0 V. T_A = 25 °C. Minimum and maximum values in this table represent the worst conditions across process variation, operating supply voltage range, and operating temperature range.

Table 4.12. High Frequency RC Oscillator (HFRCO)

Parameter	Symbol	Test Condition	Min	Typ	Max	Unit
Frequency Accuracy	F _{HFRCO_ACC}	For all production calibrated frequencies	-3	—	3	%
Current consumption on all supplies ¹	I _{HFRCO}	F _{HFRCO} = 4 MHz	—	28	—	μA
		F _{HFRCO} = 5 MHz ²	—	29	—	μA
		F _{HFRCO} = 7 MHz	—	59	—	μA
		F _{HFRCO} = 10 MHz ²	—	63	—	μA
		F _{HFRCO} = 13 MHz	—	77	—	μA
		F _{HFRCO} = 16 MHz	—	87	—	μA
		F _{HFRCO} = 19 MHz	—	90	—	μA
		F _{HFRCO} = 20 MHz ²	—	107	—	μA
		F _{HFRCO} = 26 MHz	—	116	—	μA
		F _{HFRCO} = 32 MHz	—	139	—	μA
		F _{HFRCO} = 38 MHz ³	—	170	—	μA
		F _{HFRCO} = 40 MHz ²	—	172	—	μA
		F _{HFRCO} = 48 MHz ³	—	207	—	μA
		F _{HFRCO} = 56 MHz ³	—	228	—	μA
F _{HFRCO} = 64 MHz ³	—	269	—	μA		
F _{HFRCO} = 80 MHz ³	—	285	—	μA		
Clock Out current for HFRCODPLL ⁴	I _{CLKOUT_HFRCODPLL}	FORCEEN bit of HFRCO0_CTRL = 1	—	4.5	—	μA/MHz
Clock Out current for HFRCOEM23 ⁴	I _{CLKOUT_HFRCOEM23}	FORCEEN bit of HFRCOEM23_CTRL = 1	—	2.0	—	μA/MHz
Startup Time ⁵	T _{STARTUP}	FREQRANGE = 0 to 7	—	1.2	—	μs
		FREQRANGE = 8 to 15	—	0.6	—	μs

Parameter	Symbol	Test Condition	Min	Typ	Max	Unit
Band Frequency Limits ⁶	f _{HFRCO_BAND}	FREQRANGE = 0	3.71	—	5.24	MHz
		FREQRANGE = 1	4.39	—	6.26	MHz
		FREQRANGE = 2	5.25	—	7.55	MHz
		FREQRANGE = 3	6.22	—	9.01	MHz
		FREQRANGE = 4	7.88	—	11.6	MHz
		FREQRANGE = 5	9.9	—	14.6	MHz
		FREQRANGE = 6	11.5	—	17.0	MHz
		FREQRANGE = 7	14.1	—	20.9	MHz
		FREQRANGE = 8	16.4	—	24.7	MHz
		FREQRANGE = 9	19.8	—	30.4	MHz
		FREQRANGE = 10	22.7	—	34.9	MHz
		FREQRANGE = 11	28.6	—	44.4	MHz
		FREQRANGE = 12	33.0	—	51.0	MHz
		FREQRANGE = 13	42.2	—	64.6	MHz
		FREQRANGE = 14	48.8	—	74.8	MHz
FREQRANGE = 15	57.6	—	87.4	MHz		

Note:

1. Does not include additional clock tree current. See specifications for additional current when selected as a clock source for a particular clock multiplexer.
2. This frequency is calibrated for the HFRCOEM23 only.
3. This frequency is calibrated for the HFRCODPLL (HFRCO0) only.
4. When the HFRCO is enabled for characterization using the FORCEEN bit, the total current will be the HFRCO core current plus the specified CLKOUT current. When the HFRCO is enabled on demand, the clock current may be different.
5. Hardware delay ensures settling to within ± 0.5%. Hardware also enforces this delay on a band change.
6. The frequency band limits represent the lowest and highest frequency which each band can achieve over the operating range.

4.9.4 Fast Start-Up RC Oscillator (FSRCO)

Table 4.13. Fast Start-Up RC Oscillator (FSRCO)

Parameter	Symbol	Test Condition	Min	Typ	Max	Unit
FSRCO frequency	F _{FSRCO}		17.2	20	21.2	MHz

4.9.5 Precision Low Frequency RC Oscillator (LFRCO)

Table 4.14. Precision Low Frequency RC Oscillator (LFRCO)

Parameter	Symbol	Test Condition	Min	Typ	Max	Unit
Nominal oscillation frequency	F_{LFRCO}		—	32.768	—	kHz
Frequency accuracy	F_{LFRCO_ACC}	Normal mode	-3	—	3	%
		Precision mode ¹ , across operating temperature range ²	-500	—	500	ppm
Startup time	$t_{STARTUP}$	Normal mode	—	204	—	μ s
		Precision mode ¹	—	11.7	—	ms
Current consumption	I_{LFRCO}	Normal mode	—	189.9	—	nA
		Precision mode ¹ , T = stable at 25 °C ³	—	649.8	—	nA

Note:

1. The LFRCO operates in high-precision mode when CFG_HIGHPRECEN is set to 1. High-precision mode is not available in EM4.
2. Includes ± 40 ppm frequency tolerance of the HFXO crystal.
3. Includes periodic re-calibration against HFXO crystal oscillator.

4.9.6 Ultra Low Frequency RC Oscillator (ULFRCO)

Table 4.15. Ultra Low Frequency RC Oscillator (ULFRCO)

Parameter	Symbol	Test Condition	Min	Typ	Max	Unit
Oscillation Frequency	F_{ULFRCO}		0.944	1.0	1.095	kHz

4.10 GPIO Pins (GPIO)

Table 4.16. GPIO Pins (GPIO)

Parameter	Symbol	Test Condition	Min	Typ	Max	Unit
Leakage current	I_{LEAK_IO}	MODEx = DISABLED, IOVDD = 1.71 V	—	1.9	—	nA
		MODEx = DISABLED, IOVDD = 3.0 V	—	2.5	—	nA
		MODEx = DISABLED, IOVDD = 3.8 V $T_A = 125\text{ }^\circ\text{C}$, PB00-PB03, PC06-PC09, PA00	—	—	250	nA
		MODEx = DISABLED, IOVDD = 3.8 V $T_A = 125\text{ }^\circ\text{C}$, All Other Pins	—	—	200	nA
Input low voltage ¹	V_{IL}	Any GPIO pin	—	—	0.3 * IOVDD	V
		RESETn	—	—	0.3 * DVDD	V
Input high voltage ¹	V_{IH}	Any GPIO pin	0.7 * IOVDD	—	—	V
		RESETn	0.7 * DVDD	—	—	V
Hysteresis of input voltage	V_{HYS}	Any GPIO pin	0.05 * IOVDD	—	—	V
		RESETn	0.05 * DVDD	—	—	V
Output high voltage	V_{OH}	Sourcing 20 mA, IOVDD = 3.0 V	0.8 * IOVDD	—	—	V
		Sourcing 8 mA, IOVDD = 1.71 V	0.6 * IOVDD	—	—	V
Output low voltage	V_{OL}	Sinking 20 mA, IOVDD = 3.0 V	—	—	0.2 * IOVDD	V
		Sinking 8 mA, IOVDD = 1.71 V	—	—	0.4 * IOVDD	V
GPIO rise time	T_{GPIO_RISE}	IOVDD = 3.0 V, $C_{load} = 50\text{ pF}$, SLEWRATE = 4, 10% to 90%	—	8.4	—	ns
		IOVDD = 1.71 V, $C_{load} = 50\text{ pF}$, SLEWRATE = 4, 10% to 90%	—	13	—	ns
GPIO fall time	T_{GPIO_FALL}	IOVDD = 3.0 V, $C_{load} = 50\text{ pF}$, SLEWRATE = 4, 90% to 10%	—	7.1	—	ns
		IOVDD = 1.71 V, $C_{load} = 50\text{ pF}$, SLEWRATE = 4, 90% to 10%	—	11.9	—	ns
Pull up/down resistance ²	R_{PULL}	Any GPIO pin. Pull-up to IOVDD: MODEn = DISABLE DOUT=1. Pull-down to VSS: MODEn = WIREORPULLDOWN DOUT = 0.	33	44	55	kΩ
		RESETn pin. Pull-up to DVDD	33	44	55	kΩ
Maximum filtered glitch width	T_{GF}	MODE = INPUT, DOUT = 1	—	27	—	ns

Parameter	Symbol	Test Condition	Min	Typ	Max	Unit
RESETn low time to ensure pin reset	T _{RESET}		100	—	—	ns

Note:

1. GPIO input thresholds are proportional to the IOVDD pin. RESETn input thresholds are proportional to DVDD.
2. GPIO pull-ups connect to IOVDD supply, pull-downs connect to VSS. RESETn pull-up connects to DVDD.

4.11 Analog to Digital Converter (IADC)

Specified at 1 Msps, ADCCLK = 10 MHz, OSR=2, unless otherwise indicated. If spec conditions specify "T_A = 25 °C", then minimum and/or maximum values for that spec represent the worst conditions across process variation at T_A = 25 °C. Otherwise, minimum and maximum values represent the worst conditions across supply voltage, process variation, and operating temperature.

Table 4.17. Analog to Digital Converter (IADC)

Parameter	Symbol	Test Condition	Min	Typ	Max	Unit
Main analog supply	V _{AVDD}	Normal mode	1.71	—	3.8	V
		High-Speed mode	1.71	—	3.8	V
		High-Accuracy mode	1.71	—	3.8	V
Maximum Input Range ¹	V _{IN_MAX}	Maximum allowable input voltage	0	—	AVDD	V
Full-Scale Voltage	V _{FS}	Voltage required for Full-Scale measurement	—	V _{REF} / Gain	—	V
Input Measurement Range	V _{IN}	Differential Mode - Plus and Minus inputs	-V _{FS}	—	+V _{FS}	V
		Single Ended Mode - One input tied to ground	0	—	V _{FS}	V
Input Sampling Capacitance	C _s	Analog Gain = 1x	—	1.8	—	pF
		Analog Gain = 2x	—	3.6	—	pF
		Analog Gain = 3x	—	5.4	—	pF
		Analog Gain = 4x	—	7.2	—	pF
		Analog Gain = 0.5x	—	0.9	—	pF
ADC clock frequency	f _{ADC_CLK}	Normal mode, Gain = 1x or 0.5x	—	—	10	MHz
		Normal mode, Gain = 2x	—	—	5	MHz
		Normal mode, Gain = 3x or 4x	—	—	2.5	MHz
		High-Speed mode, Gain = 1x or 0.5x	—	—	20	MHz
		High-Speed mode, Gain = 2x	—	—	10	MHz
		High-Speed mode, Gain = 3x or 4x	—	—	5	MHz
		High-Accuracy mode	—	—	5	MHz
Input sampling frequency	f _s	Normal Mode	—	f _{ADC_CLK} /4	—	MHz
		High-Speed Mode	—	f _{ADC_CLK} /4	—	MHz
		High-Accuracy Mode	—	f _{ADC_CLK} /5	—	MHz

Parameter	Symbol	Test Condition	Min	Typ	Max	Unit
Throughput rate	f_{SAMPLE}	Normal mode, $f_{\text{ADC_CLK}} = 10$ MHz, OSR = 2	—	—	1	Msp/s
		Normal mode, $f_{\text{ADC_CLK}} = 10$ MHz, OSR = 32	—	—	76.9	ksps
		High-Speed mode, $f_{\text{ADC_CLK}} = 20$ MHz, OSR = 2	—	—	2	Msp/s
		High-Accuracy mode, $f_{\text{ADC_CLK}} = 5$ MHz, OSR = 92	—	—	10.7	ksps
		High-Accuracy mode, $f_{\text{ADC_CLK}} = 5$ MHz, OSR = 256	—	—	3.88	ksps
Current from all supplies, Continuous operation	$I_{\text{ADC_CONT}}$	Normal Mode, 1 Msps, OSR = 2, $f_{\text{ADC_CLK}} = 10$ MHz, $T_A = 25$ °C	—	305	340	μA
		High-Speed Mode, 2 Msps, OSR = 2, $f_{\text{ADC_CLK}} = 20$ MHz, $T_A = 25$ °C	—	550	622	μA
		High-Accuracy Mode, 10.7 ksps, OSR = 92, $f_{\text{ADC_CLK}} = 5$ MHz, $T_A = 25$ °C	—	108	117	μA
Current in Standby mode. ADC is not functional but can wake up in 1us.	I_{STBY}	Normal mode	—	17	—	μA
		High-Speed mode	—	21	—	μA
		High-Accuracy mode	—	10	—	μA
ADC Startup Time	t_{startup}	From power down state	—	5	—	μs
		From standby state	—	1	—	μs
Normal Mode ADC Resolution ²	Resolution	OSR = 2	—	12	—	bits
		OSR = 32	—	16	—	bits
High-Speed Mode ADC Resolution ²	Resolution _{HS}	OSR = 2	—	12	—	bits
		OSR = 32	—	16	—	bits
High-Accuracy Mode ADC Resolution	Resolution _{HA}	High Accuracy mode. Typical value is for default OSR = 92 for 10.7 ksps, max value is limited by code length.	—	16	20	bits
Differential Nonlinearity	DNL	Normal mode. Differential Input. OSR = 2 (No missing codes)	-1	+/- 0.25	1.5	LSB12
		High Speed mode. Differential Input. OSR = 2	-1	+/- 0.25	1.5	LSB12
		High-Accuracy mode ³ . Differential Input. 10.7 ksps with OSR = 92	-1	—	1	LSB16
Integral Nonlinearity	INL	Normal mode. Differential Input, OSR = 2	-2.5	+/- 0.65	2.5	LSB12
		High-Speed mode. Differential Input.	-2.5	+/- 0.65	2.5	LSB12
		High-Accuracy mode ³ . Differential Input. External VREF = 1.25 V. 10.7 ksps with OSR = 92	—	+/- 0.25	—	LSB16

Parameter	Symbol	Test Condition	Min	Typ	Max	Unit
Effective number of bits ⁴	ENOB	Normal Mode, Differential Input. Gain = 1x, OSR = 2, $f_{IN} = 10$ kHz, Internal VREF = 1.21V	10.7	11.7	—	bits
		Normal Mode, Differential Input. Gain = 1x, OSR = 32, $f_{IN} = 2.5$ kHz, Internal VREF = 1.21 V.	—	13.5	—	bits
		Normal Mode, Differential Input. Gain = 1x, OSR = 32, $f_{IN} = 2.5$ kHz, External VREF = 1.25 V.	—	14.3	—	bits
		High Speed mode. Differential Input. Gain = 1x, OSR = 2, $f_{IN} = 10$ kHz, Internal VREF = 1.21 V	10.7	11.5	—	bits
		High-Accuracy mode ³ . Differential Input. Gain = 1x, $f_{IN} = 100$ Hz, External VREF = 1.25 V. 10.7 kspcs with OSR = 92	14	15.3	—	bits
		High-Accuracy mode ³ . Differential Input. Gain = 1x, $f_{IN} = 100$ Hz, External VREF = 1.25 V. 3.88 kspcs with OSR = 256	—	16.1	—	bits
Signal to Noise + Distortion Ratio Normal Mode ⁴	SNDR	Differential Input. Gain=1x, OSR = 2, $f_{IN} = 10$ kHz, Internal VREF = 1.21V	66	72.3	—	dB
		Differential Input. Gain=2x, OSR = 2, $f_{IN} = 10$ kHz, Internal VREF = 1.21V	—	72.3	—	dB
		Differential Input. Gain=4x, OSR = 2, $f_{IN} = 10$ kHz, Internal VREF = 1.21V	—	68.8	—	dB
		Differential Input. Gain=0.5x, OSR = 2, $f_{IN} = 10$ kHz, Internal VREF = 1.21V	—	72.5	—	dB
		Differential Input. Gain = 1x, OSR = 64, $f_{IN} = 1.25$ kHz, Internal VREF = 1.21 V	—	83.9	—	dB
Signal to Noise + Distortion Ratio High-Speed mode	SNDR _{HS}	High Speed mode. Differential Input. Gain = 1x, OSR = 2, $f_{IN} = 10$ kHz, Internal VREF = 1.21 V	66	72.3	—	dB
		High Speed mode. Differential Input. Gain = 2x, OSR = 2, $f_{IN} = 10$ kHz, Internal VREF = 1.21 V	—	72.3	—	dB
		High Speed mode. Differential Input. Gain = 4x, OSR = 2, $f_{IN} = 10$ kHz, Internal VREF = 1.21 V	—	68.8	—	dB
		High Speed mode. Differential Input. Gain = 0.5x, OSR = 2, $f_{IN} = 10$ kHz, Internal VREF = 1.21 V	—	72.5	—	dB

Parameter	Symbol	Test Condition	Min	Typ	Max	Unit
Signal to Noise + Distortion Ratio High-Accuracy mode ³	SNDR _{HA}	High-Accuracy. Differential Input. Gain = 1x, f_{IN} = 100 Hz, External VREF = 1.25 V. 3.88 ksp/s with OSR = 256	—	98.7	—	dB
		High-Accuracy. Differential Input. Gain = 1x, f_{IN} = 100 Hz, External VREF = 1.25 V. 10.7 ksp/s with OSR = 92	86	93.8	—	dB
		High-Accuracy. Differential Input. Gain = 2x, f_{IN} = 100 Hz, External VREF = 1.25 V. 10.7 ksp/s with OSR = 92	—	93.5	—	dB
		High-Accuracy. Differential Input. Gain = 4x, f_{IN} = 100 Hz, External VREF = 1.25 V. 10.7 ksp/s with OSR = 92	—	91.0	—	dB
		High-Accuracy. Differential Input. Gain = 0.5x, f_{IN} = 100 Hz, External VREF = 1.25 V. 10.7 ksp/s with OSR = 92	—	94.7	—	dB
Total Harmonic Distortion	THD	Normal mode, Differential Input. Gain = 1x, OSR = 2, f_{IN} = 10 kHz, Internal VREF = 1.21 V	—	-80.8	-70	dB
		High Speed mode, Differential Input. Gain = 1x, OSR = 2, f_{IN} = 10 kHz, Internal VREF = 1.21 V	—	-84.3	-70	dB
		High-Accuracy mode ³ , Differential Input. f_{IN} = 100 Hz, External VREF = 1.25 V. 10.7 ksp/s with OSR = 92	—	-101	-80	dB
Spurious-Free Dynamic Range	SFDR	Normal mode, Differential Input. Gain = 1x, OSR = 2, f_{IN} = 10 kHz, Internal VREF = 1.21 V	72	86.5	—	dB
		High Speed mode, Differential Input. Gain = 1x, f_{IN} = 10 kHz, Internal VREF = 1.21 V	72	84.3	—	dB
		High-Accuracy mode ³ , Differential Input. f_{IN} = 100 Hz, External VREF = 1.25 V. 10.7 ksp/s with OSR = 92	100	118.1	—	dB
Common Mode Rejection Ratio	CMRR	Normal mode. DC to 100 Hz	—	87.0	—	dB
		Normal mode. AC high frequency.	—	68.6	—	dB
		High-Speed mode. DC to 100 Hz	—	86.3	—	dB
		High-Speed mode. AC high frequency.	—	59.0	—	dB
		High-Accuracy mode ³ . DC to 100 Hz	—	93.8	—	dB
		High Accuracy mode ³ . AC high frequency.	—	87.0	—	dB

Parameter	Symbol	Test Condition	Min	Typ	Max	Unit
Power Supply Rejection Ratio	PSRR	Normal mode. DC to 100 Hz	—	80.4	—	dB
		Normal mode. AC high frequency, using internal VBGR	—	33.4	—	dB
		Normal mode. AC high frequency, using VREF pad	—	65.2	—	dB
		High Speed modes. DC to 100 Hz	—	79.8	—	dB
		High-Speed mode. AC high frequency, using internal VBGR	—	31.0	—	dB
		High Speed mode. AC high frequency, using VREF pad	—	65.0	—	dB
		High Accuracy mode ³ . DC to 100 Hz	—	124	—	dB
		High-Accuracy mode ³ . AC high frequency, using external VREF pin.	—	85.0	—	dB
External reference voltage range ¹	V _{EVREF}		1.0	—	AVDD	V
Offset Error, Normal mode	OFFSET	GAIN = 1 and 0.5, Differential Input	-3	0.27	3	LSB12
		GAIN = 2, Differential Input	-4	0.27	4	LSB12
		GAIN = 3, Differential Input	-4	0.25	4	LSB12
		GAIN = 4, Differential Input	-4	0.29	4	LSB12
Offset Error, High-speed mode	OFFSET _{HS}	GAIN = 1 and 0.5, Differential Input	-3	0.27	3	LSB12
		GAIN = 2, Differential Input	-4	0.27	4	LSB12
		GAIN = 3, Differential Input	-4	0.25	4	LSB12
		GAIN = 4, Differential Input	-4	0.29	4	LSB12
Offset Error, High-accuracy mode ³	OFFSET _{HA}	All GAIN settings, Differential Input	-7	-0.011	7	LSB16
Gain Error, Normal mode	GE	GAIN = 1 and 0.5, using external VREF, f _{ADC_CLK} = 10 MHz	-0.6	-0.155	0.6	%
		GAIN = 2, using external VREF, f _{ADC_CLK} = 5 MHz	-0.6	-0.155	0.6	%
		GAIN = 3, using external VREF, f _{ADC_CLK} = 2.5 MHz	-0.7	0.186	0.7	%
		GAIN = 4, using external VREF, f _{ADC_CLK} = 2.5 MHz	-1.1	0.227	1.1	%
		Internal VREF ⁵ , all GAIN settings	-1.5	0.023	1.5	%

Parameter	Symbol	Test Condition	Min	Typ	Max	Unit
Gain Error, High-speed mode	GE _{HS}	GAIN = 1 and 0.5, using external VREF, f _{ADC_CLK} = 20 MHz	-0.6	-0.155	0.6	%
		GAIN = 2, using external VREF, f _{ADC_CLK} = 10 MHz	-0.6	-0.055	0.6	%
		GAIN = 3, using external VREF, f _{ADC_CLK} = 5 MHz	-0.7	0.186	0.7	%
		GAIN = 4, using external VREF, f _{ADC_CLK} = 5 MHz	-1.1	0.227	1.1	%
		Internal VREF ⁵ , all GAIN settings	-1.5	0.023	1.5	%
Gain Error, High-accuracy mode ³	GE _{HA}	GAIN = 1 and 0.5, using external VREF	-0.5	0.006	0.5	%
		GAIN = 2, using external VREF	-0.5	-0.067	0.5	%
		GAIN = 3, using external VREF	-0.5	-0.070	0.5	%
		GAIN = 4, using external VREF	-0.5	-0.098	0.5	%
Internal Reference voltage	V _{IVREF}		—	1.21	—	V

Note:

- When inputs are routed to external GPIO pins, the maximum pin voltage is limited to the lower of the IOVDD and AVDD supplies.
- ADC output resolution depends on the OSR and digital averaging settings. With no digital averaging, ADC output resolution is 12 bits at OSR = 2, 13 bits at OSR = 4, 14 bits at OSR = 8, 15 bits at OSR = 16, 16 bits at OSR = 32 and 17 bits at OSR = 64. Digital averaging has a similar impact on ADC output resolution. See the product reference manual for additional details.
- High-Accuracy mode performance specifications are tested with inputs applied to the dedicated AIN pins.
- The relationship between ENOB and SNDR is specified according to the equation: $ENOB = (SNDR - 1.76) / 6.02$.
- Includes error from internal VREF drift.

4.12 Analog Comparator (ACMP)

If spec conditions specify " $T_A = 25\text{ }^\circ\text{C}$ ", then minimum and/or maximum values for that spec represent the worst conditions across process variation at $T_A = 25\text{ }^\circ\text{C}$. Otherwise, minimum and maximum values represent the worst conditions across supply voltage, process variation, and operating temperature.

Table 4.18. Analog Comparator (ACMP)

Parameter	Symbol	Test Condition	Min	Typ	Max	Unit
ACMP Supply current	I_{ACMP}	BIAS = 0 ¹ , HYST = DISABLED	—	71	—	nA
		BIAS = 1 ¹ , HYST = DISABLED	—	270	—	nA
		BIAS = 2 ¹ , HYST = DISABLED	—	668	—	nA
		BIAS = 3 ¹ , HYST = DISABLED	—	2.5	—	μA
		BIAS = 4, HYST = DISABLED	—	5.4	—	μA
		BIAS = 5, HYST = DISABLED	—	10.6	—	μA
		BIAS = 6, HYST = DISABLED	—	27	—	μA
		BIAS = 7, HYST = DISABLED, $T_A = 25\text{ }^\circ\text{C}$	—	50	70	μA
ACMP Supply current with Hysteresis	I_{ACMP_WHYS}	BIAS = 0 ¹ , HYST = SYM30MV	—	91	—	nA
		BIAS = 1 ¹ , HYST = SYM30MV	—	368	—	nA
		BIAS = 2 ¹ , HYST = SYM30MV	—	921	—	nA
		BIAS = 3 ¹ , HYST = SYM30MV	—	3.4	—	μA
		BIAS = 4, HYST = SYM30MV	—	7.3	—	μA
		BIAS = 5, HYST = SYM30MV	—	15	—	μA
		BIAS = 6, HYST = SYM30MV	—	38	—	μA
		BIAS = 7, HYST = SYM30MV	—	71	—	μA
Current consumption from VREFDIV in continuous mode	$I_{VREFDIV}$	NEGSEL = VREFDIVAVDD	—	3.2	—	μA
		NEGSEL = VREFDIV1V25	—	4.3	—	μA
		NEGSEL = VREFDIV2V5	—	7.1	—	μA
Current consumption from VREFDIV in sample/hold mode	$I_{VREFDIV_SH}$	NEGSEL = VREFDIV2V5LP	—	81	—	nA
		NEGSEL = VREFDIV1V25LP	—	74	—	nA
		NEGSEL = VREFDIVAVDDL	—	76	—	nA
Current consumption from VSENSEDIV in continuous mode	$I_{VSENSEDIV}$	NEGSEL = VSENSE01DIV4	—	1.7	—	μA
Current consumption from VSENSEDIV in sample/hold mode	$I_{VSENSEDIV_SH}$	NEGSEL = VSENSE01DIV4LP	—	59.1	—	nA
Hysteresis (BIAS = 0)	V_{HYST}	HYST = SYM10MV ²	—	18	—	mV
		HYST = SYM20MV ²	—	33	—	mV
		HYST = SYM30MV ²	—	47	—	mV

Parameter	Symbol	Test Condition	Min	Typ	Max	Unit
Reference Voltage	V _{ACMPREF}	Internal 1.25 V Reference	1.19	1.25	1.31	V
		Internal 2.5 V Reference	2.34	2.5	2.75	V
Input offset voltage	V _{OFFSET}	BIAS = 0, V _{CM} = 0.15 to AVDD - 0.15 V	-25	—	25	mV
		BIAS = 3, V _{CM} = 0.15 to AVDD - 0.15 V	-25	—	25	mV
		BIAS = 4, V _{CM} = 0.15 to AVDD - 0.15 V	-25	—	25	mV
		BIAS = 7, V _{CM} = 0.15 to AVDD - 0.15 V	-30	—	30	mV
Input Range	V _{IN}	Input Voltage Range	0	—	AVDD	V
Comparator delay with 100 mV overdrive	T _{DELAY}	BIAS = 0	—	10	—	μs
		BIAS = 1	—	2.7	—	μs
		BIAS = 2	—	1.4	—	μs
		BIAS = 3	—	0.58	—	μs
		BIAS = 4	—	224	—	ns
		BIAS = 5	—	133	—	ns
		BIAS = 6	—	80	—	ns
		BIAS = 7	—	63	—	ns

Note:

1. When using the 1.25 V or 2.5 V VREF in continuous mode (VREFDIV1V25 or VREFDIV2V5) and BIAS < 4, an additional 1 μA of supply current is required.
2. V_{CM} = 1.25 V

4.13 Digital to Analog Converter (VDAC)

If spec conditions specify " $T_A = 25\text{ }^\circ\text{C}$ ", then minimum and/or maximum values for that spec represent the worst conditions across process variation at $T_A = 25\text{ }^\circ\text{C}$. Otherwise, minimum and maximum values represent the worst conditions across supply voltage, process variation, and operating temperature.

Table 4.19. Digital to Analog Converter (VDAC)

Parameter	Symbol	Test Condition	Min	Typ	Max	Unit
Output voltage	V_{DACOUT}		0	—	VREF	V
Output Current	I_{DACOUT}		-10	—	10	mA
DAC clock frequency	f_{DAC}		—	—	1	MHz
Sample rate	SR_{DAC}	$f_{\text{DAC}} = f_{\text{DAC(max)}}$	—	—	500	ksps
Resolution	$N_{\text{RESOLUTION}}$		—	12	—	bits
Load Capacitance ¹	C_{LOAD}	High Power and Lower Power Modes	—	—	50	pF
		High Capacitance Load Mode	25	—	—	nF
Load Resistance	R_{LOAD}		5	—	—	k Ω
Current consumption, Dynamic, 500 ksps, 1 channel active ²	$I_{\text{DAC}_1_{500}}$	High Power Mode	—	228	—	μA
		Low Power Mode	—	125	—	μA
Current consumption, Dynamic, 500 ksps, 2 channels active ²	$I_{\text{DAC}_2_{500}}$	High Power Mode	—	433	—	μA
		Low Power Mode	—	230	—	μA
Current consumption, Static, 1 channel active ³	$I_{\text{DAC}_1_{\text{STAT}}}$	High Power Mode	—	135	—	μA
		Low Power Mode	—	32	—	μA
		High Capacitance Mode	—	42	—	μA
Current consumption, Static, 2 channels active ³	$I_{\text{DAC}_2_{\text{STAT}}}$	High Power Mode, $T_A = 25\text{ }^\circ\text{C}$	—	260	319	μA
		Low Power Mode, $T_A = 25\text{ }^\circ\text{C}$	—	53	60	μA
		High Capacitance Mode	—	76	—	μA
Startup time	$t_{\text{DACSTARTUP}}$	Enable to 90% full scale output, settling to 10 LSB	—	4.5	4.9	μs
Settling time	$t_{\text{DACSETTLE}}$	High Power Mode, 25% to 75% of full scale, settling to 10 LSB	—	1.1	1.6	μs
		Low Power Mode, 25% to 75% of full scale, settling to 1%	—	2.7	—	μs
Output impedance	R_{OUT}	Main Output, High Power Mode	—	2.1	—	Ω
		Main Output, Low Power Mode	—	3.5	—	Ω
Power supply rejection ratio ⁴	PSRR	$V_{\text{out}} = 50\%$ full scale, DC output	—	72	—	dB
Signal to noise and distortion ratio	$SNDR_{\text{DAC}}$	High Power mode, 500 ksps, internal 2.5 V reference, 1 kHz sine wave input, BW limited to 250 kHz	65.8	64.8	—	dB
		High Power mode, 500 ksps, internal 2.5 V reference, 1 kHz sine wave input, BW limited to 22 kHz	68	67.4	—	dB

Parameter	Symbol	Test Condition	Min	Typ	Max	Unit
Total Harmonic Distortion	THD	High Power Mode, internal 2.5 V reference, 1 kHz sine wave input	—	-68.8	-62.4	dB
Integral Non-Linearity	INL _{DAC}	High Power Mode, Across full temperature range	5	—	5	LSB
Differential Non-Linearity ⁵	DNL _{DAC}	High Power Mode, Across full temperature range	-1	—	1.3	LSB
Offset error ⁶	V _{OFFSET}	High Power mode	-15	—	15	mV
		Low Power Mode	-25	—	25	mV
		High Capacitance Load mode	-35	—	35	mV
Gain error ⁶	V _{GAIN}	1.25 V internal reference	-1.5	—	1.5	%
		2.5 V internal reference	-2	—	2	%
		External Reference	-0.6	—	0.6	%
External Reference Voltage ⁷	V _{EXTREF}		1.1	—	V_AVDD	V

Note:

1. Main outputs only.
2. Dynamic current specifications are for VDAC circuitry operating at max clock frequency with the output updated at the specified sampling rate using DMA transfers. Output is a 1 kHz sine wave from 10% to 90% full scale. Specified current does not include current required to drive the external load. Measurement includes all current from AVDD and DVDD supplies.
3. Static current specifications are for VDAC circuitry operating after a one-time update to a static output at 50% full scale, with the VDAC APB clock disabled. Specified current does not include current required to drive the external load. Measurement includes all current from AVDD and DVDD supplies.
4. PSRR calculated as $20 * \log_{10}(\Delta V_{DD} / \Delta V_{OUT})$.
5. Entire range is monotonic and has no missing codes.
6. Gain is calculated by measuring the slope from 10% to 90% of full scale. Offset is calculated by comparing actual VDAC output at 10% of full scale to ideal VDAC output at 10% of full scale with the measured gain.
7. External reference voltage on VREFP pin or PA00 when used for VREFP

4.14 Temperature Sensor

Table 4.20. Temperature Sensor

Parameter	Symbol	Test Condition	Min	Typ	Max	Unit
Temperature sensor range ¹	T _{RANGE}		-40	—	125	°C
Temperature sensor resolution	T _{RESOLUTION}		—	0.25	—	°C
Measurement noise (RMS)	T _{NOISE}	Single measurement	—	0.6	—	°C
		16-sample average (TEMPAVG- NUM = 0)	—	0.17	—	°C
		64-sample average (TEMPAVG- NUM = 1)	—	0.12	—	°C
Temperature offset	T _{OFF}	Mean error of uncorrected output across full temperature range	—	3.2	—	°C
Temperature sensor accuracy ^{2 3}	T _{ACC}	Direct output accuracy after mean error (T _{OFF}) removed	—	+/-3	—	°C
		After linearization in software, no calibration	—	+/-2	—	°C
		After linearization in software, with single-temperature calibration at 25 °C ⁴	—	+/-1.5	—	°C
Measurement interval	t _{MEAS}		—	250	—	ms

Note:

1. The sensor reports absolute die temperature in Kelvin (K). All specifications are in °C to match the units of the specified product temperature range.
2. Error is measured as the deviation of the mean temperature reading from the expected die temperature. Accuracy numbers represent statistical minimum and maximum using ± 4 standard deviations of measured error.
3. The raw output of the temperature sensor is a predictable curve. It can be linearized with a polynomial function for additional accuracy.
4. Assuming calibration accuracy of ± 0.25 °C.

4.15 Brown Out Detectors

4.15.1 DVDD BOD

BOD thresholds on DVDD in EM0 and EM1 only, unless otherwise noted. Typical conditions are at $T_A = 25\text{ }^\circ\text{C}$. Minimum and maximum values in this table represent the worst conditions across process variation, operating supply voltage range, and operating temperature range.

Table 4.21. DVDD BOD

Parameter	Symbol	Test Condition	Min	Typ	Max	Unit
BOD threshold	V_{DVDD_BOD}	Supply Rising	—	1.67	1.71	V
		Supply Falling	1.62	1.65	—	V
BOD response time	$t_{DVDD_BOD_DELAY}$	Supply dropping at 100 mV/ μ s slew rate ¹	—	0.95	—	μ s
BOD hysteresis	$V_{DVDD_BOD_HYS_T}$		—	25	—	mV

Note:

1. If the supply slew rate exceeds the specified slew rate, the BOD may trip later than expected (at a threshold below the minimum specified threshold), or the BOD may not trip at all (e.g., if the supply ramps down and then back up at a very fast rate)

4.15.2 Low-Energy DVDD BOD

BOD thresholds on DVDD pin for low energy modes EM2 to EM4, unless otherwise noted.

Table 4.22. Low-Energy DVDD BOD

Parameter	Symbol	Test Condition	Min	Typ	Max	Unit
BOD threshold	$V_{DVDD_LE_BOD}$	Supply Falling	1.5	—	1.71	V
BOD response time	$t_{DVDD_LE_BOD_DELAY}$	Supply dropping at 2 mV/ μ s slew rate ¹	—	50	—	μ s
BOD hysteresis	$V_{DVDD_LE_BOD_HYST}$		—	20	—	mV

Note:

1. If the supply slew rate exceeds the specified slew rate, the BOD may trip later than expected (at a threshold below the minimum specified threshold), or the BOD may not trip at all (e.g., if the supply ramps down and then back up at a very fast rate)

4.15.3 AVDD and IOVDD BODs

BOD thresholds for AVDD BOD and IOVDD BOD. Available in all energy modes.

Table 4.23. AVDD and IOVDD BODs

Parameter	Symbol	Test Condition	Min	Typ	Max	Unit
BOD threshold	V_{BOD}	Supply falling	1.45	—	1.71	V
BOD response time	t_{BOD_DELAY}	Supply dropping at 2 mV/ μ s slew rate ¹	—	50	—	μ s
BOD hysteresis	V_{BOD_HYST}		—	24	—	mV

Note:

1. If the supply slew rate exceeds the specified slew rate, the BOD may trip later than expected (at a threshold below the minimum specified threshold), or the BOD may not trip at all (e.g., if the supply ramps down and then back up at a very fast rate)

4.16 Pulse Counter (PCNT)

Table 4.24. Pulse Counter (PCNT)

Parameter	Symbol	Test Condition	Min	Typ	Max	Unit
Input frequency	F_{IN}	Asynchronous Single and Quadrature Modes	—	—	1.0	MHz
		Sampled Modes with Debounce filter set to 0.	—	—	8	kHz
Setup time in asynchronous external clock mode	$t_{SU_S1N_S0N}$	S1N (data) to S0N (clock)	58	—	—	ns
Hold time in asynchronous external clock mode	$t_{HD_S0N_S1N}$	S0N (clock) to S1N (data)	46	—	—	ns

4.17 USART SPI Main Timing

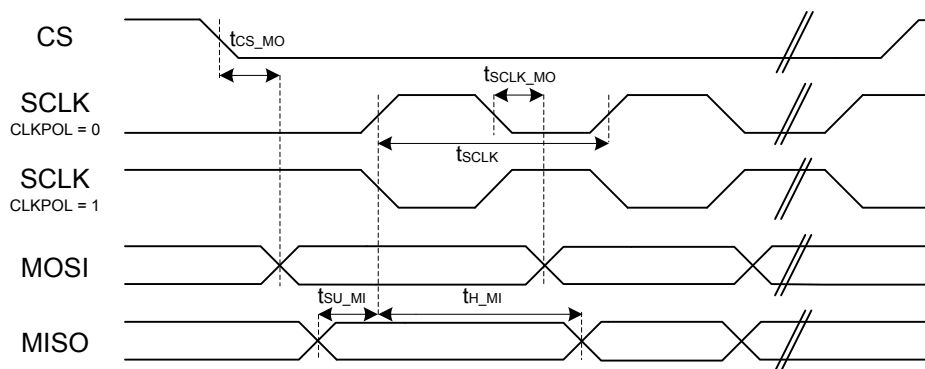

Figure 4.3. SPI Main Timing (SMSDELAY = 0)

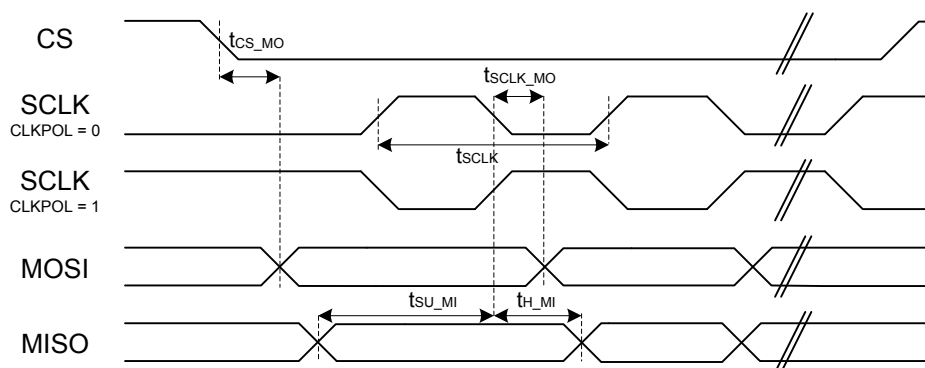

Figure 4.4. SPI Main Timing (SMSDELAY = 1)

4.17.1 USART SPI Main Timing, Voltage Scaling = VSCALE2

Timing specifications are for all SPI signals routed to the same DBUS (DBUSAB or DBUSCD). All GPIO set to slew rate = 6.

Table 4.25. USART SPI Main Timing, Voltage Scaling = VSCALE2

Parameter	Symbol	Test Condition	Min	Typ	Max	Unit
SCLK period ^{1 2 3}	t _{SCLK}		2*t _{PCLK}	—	—	ns
CS to MOSI ^{1 2}	t _{CS_MO}		-27	—	29	ns
SCLK to MOSI ^{1 2}	t _{SCLK_MO}		-12	—	24	ns
MISO setup time ^{1 2}	t _{SU_MI}	IOVDD = 1.62 V	41	—	—	ns
		IOVDD = 3.0 V	31	—	—	ns
MISO hold time ^{1 2}	t _{H_MI}		-9	—	—	ns

Note:

1. Applies for both CLKPHA = 0 and CLKPHA = 1.
2. Measurement done with 8 pF output loading at 10% and 90% of the I/O supply.
3. t_{PCLK} is one period of the selected PCLK.

4.17.2 USART SPI Main Timing, Voltage Scaling = VSCALE1

Timing specifications are for all SPI signals routed to the same DBUS (DBUSAB or DBUSCD). All GPIO set to slew rate = 6.

Table 4.26. USART SPI Main Timing, Voltage Scaling = VSCALE1

Parameter	Symbol	Test Condition	Min	Typ	Max	Unit
SCLK period ^{1 2 3}	t _{SCLK}		2*t _{PCLK}	—	—	ns
CS to MOSI ^{1 2}	t _{CS_MO}		-41	—	44	ns
SCLK to MOSI ^{1 2}	t _{SCLK_MO}		-12	—	41	ns
MISO setup time ^{1 2}	t _{SU_MI}	IOVDD = 1.62 V	47	—	—	ns
		IOVDD = 3.0 V	39	—	—	ns
MISO hold time ^{1 2}	t _{H_MI}		-9	—	—	ns

Note:

1. Applies for both CLKPHA = 0 and CLKPHA = 1.
2. Measurement done with 8 pF output loading at 10% and 90% of the I/O supply.
3. t_{PCLK} is one period of the selected PCLK.

4.18 USART SPI Secondary Timing

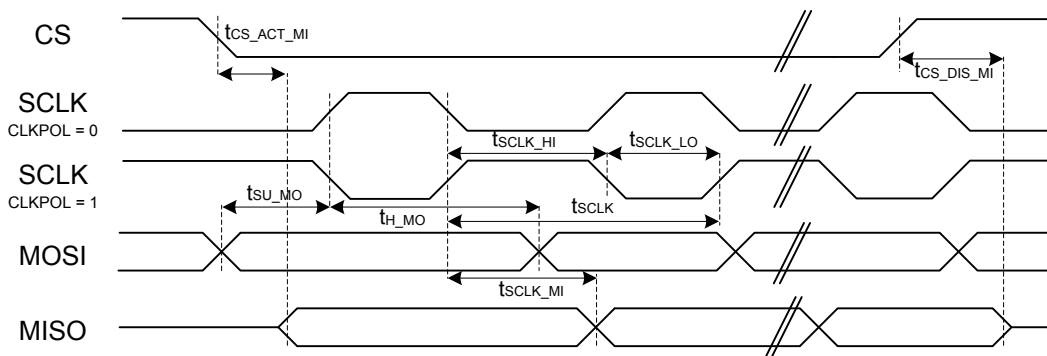

Figure 4.5. SPI Secondary Timing (SSSEARLY = 0)

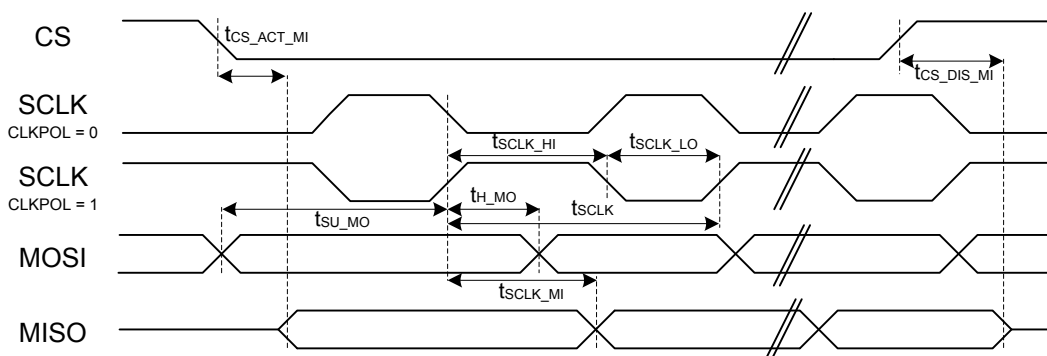

Figure 4.6. SPI Secondary Timing (SSSEARLY = 1)

4.18.1 USART SPI Secondary Timing, Voltage Scaling = VSCALE2

Timing specifications are for all SPI signals routed to the same DBUS (DBUSAB or DBUSCD). All GPIO set to slew rate = 6.

Table 4.27. USART SPI Secondary Timing, Voltage Scaling = VSCALE2

Parameter	Symbol	Test Condition	Min	Typ	Max	Unit
SCLK period ^{1 2 3}	t _{SCLK}		6*t _{PCLK}	—	—	ns
SCLK high time ^{1 2 3}	t _{SCLK_HI}		2.5*t _{PCLK}	—	—	ns
SCLK low time ^{1 2 3}	t _{SCLK_LO}		2.5*t _{PCLK}	—	—	ns
CS active to MISO ^{1 2}	t _{CS_ACT_MI}		25	—	102	ns
CS disable to MISO ^{1 2}	t _{CS_DIS_MI}		20	—	95	ns
MOSI setup time ^{1 2}	t _{SU_MO}		7	—	—	ns
MOSI hold time ^{1 2 3}	t _{H_MO}		9	—	—	ns
SCLK to MISO ^{1 2 3}	t _{SCLK_MI}		15	—	30	ns

Note:

1. Applies for both CLKPHA = 0 and CLKPHA = 1 (figure only shows CLKPHA = 0).
2. Measurement done with 8 pF output loading at 10% and 90% of the I/O supply (figure shows 50%).
3. t_{PCLK} is one period of the selected PCLK.

4.18.2 USART SPI Secondary Timing, Voltage Scaling = VSCALE1

Timing specifications are for all SPI signals routed to the same DBUS (DBUSAB or DBUSCD). All GPIO set to slew rate = 6.

Table 4.28. USART SPI Secondary Timing, Voltage Scaling = VSCALE1

Parameter	Symbol	Test Condition	Min	Typ	Max	Unit
SCLK period ^{1 2 3}	t _{SCLK}		6*t _{PCLK}	—	—	ns
SCLK high time ^{1 2 3}	t _{SCLK_HI}		2.5*t _{PCLK}	—	—	ns
SCLK low time ^{1 2 3}	t _{SCLK_LO}		2.5*t _{PCLK}	—	—	ns
CS active to MISO ^{1 2}	t _{CS_ACT_MI}		24	—	136	ns
CS disable to MISO ^{1 2}	t _{CS_DIS_MI}		23	—	129	ns
MOSI setup time ^{1 2}	t _{SU_MO}		10	—	—	ns
MOSI hold time ^{1 2 3}	t _{H_MO}		15	—	—	ns
SCLK to MISO ^{1 2 3}	t _{SCLK_MI}		17	—	39	ns

Note:

1. Applies for both CLKPHA = 0 and CLKPHA = 1 (figure only shows CLKPHA = 0).
2. Measurement done with 8 pF output loading at 10% and 90% of the I/O supply (figure shows 50%).
3. t_{PCLK} is one period of the selected PCLK.

4.19 EUSART SPI Main Timing

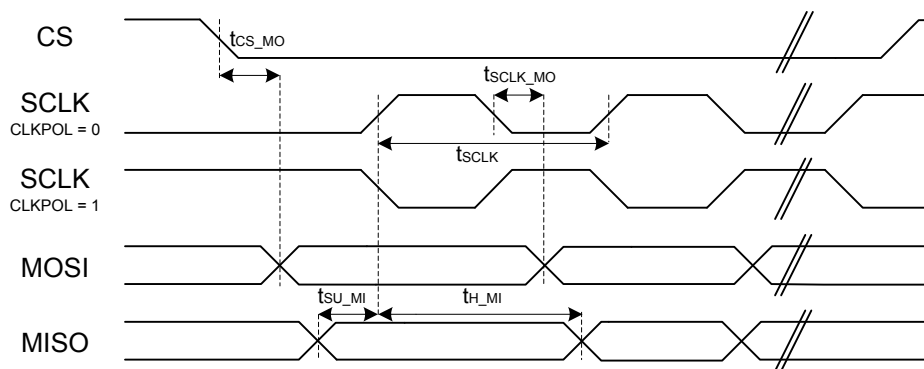

Figure 4.7. SPI Main Timing

4.19.1 EUSART SPI Main Timing, Voltage Scaling = VSCALE2

Timing specifications are for all SPI signals routed to the same DBUS (DBUSAB or DBUSCD) on consecutive pins. All GPIO set to slew rate = 6.

Table 4.29. EUSART SPI Main Timing, Voltage Scaling = VSCALE2

Parameter	Symbol	Test Condition	Min	Typ	Max	Unit
SCLK period ^{1 2 3}	t_{SCLK}		t_{CLK}	—	—	ns
CS to MOSI ^{1 2}	t_{CS_MO}		-12	—	9	ns
SCLK to MOSI ^{1 2}	t_{SCLK_MO}		-4	—	11	ns
MISO setup time ^{1 2}	t_{SU_MI}		7	—	—	ns
MISO hold time ^{1 2}	t_{H_MI}		-17	—	—	ns

Note:

1. Applies for both CLKPHA = 0 and CLKPHA = 1.
2. Measurement done with 15 pF output loading at 10% and 90% of V_{DD} .
3. t_{CLK} is one period of the selected peripheral clock: EM01GRPCCLK for EUSART1/2, EUSART0CLK for EUSART0.

4.19.2 EUSART SPI Main Timing, Voltage Scaling = VSCALE1

Timing specifications are for all SPI signals routed to the same DBUS (DBUSAB or DBUSCD) on consecutive pins. All GPIO set to slew rate = 6.

Table 4.30. EUSART SPI Main Timing, Voltage Scaling = VSCALE1

Parameter	Symbol	Test Condition	Min	Typ	Max	Unit
SCLK period ^{1 2 3}	t _{SCLK}		t_CLK	—	—	ns
CS to MOSI ^{1 2}	t _{CS_MO}		-20	—	15	ns
SCLK to MOSI ^{1 2}	t _{SCLK_MO}		-4	—	15	ns
MISO setup time ^{1 2}	t _{SU_MI}		12	—	—	ns
MISO hold time ^{1 2}	t _{H_MI}		-11	—	—	ns

Note:

1. Applies for both CLKPHA = 0 and CLKPHA = 1.
2. Measurement done with 15 pF output loading at 10% and 90% of V_{DD}.
3. t_{CLK} is one period of the selected peripheral clock: EM01GRPCCLK for EUSART1/2, EUSART0CLK for EUSART0.

4.20 EUSART SPI Secondary Timing

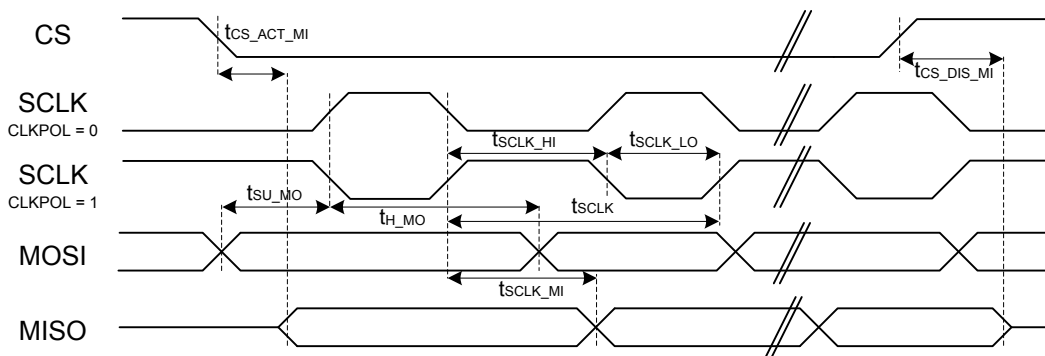

Figure 4.8. SPI Secondary Timing

4.20.1 EUSART SPI Secondary Timing, Voltage Scaling = VSCALE2

Timing specifications are for all SPI signals routed to the same DBUS (DBUSAB or DBUSCD) on consecutive pins. All GPIO set to slew rate = 6.

Table 4.31. EUSART SPI Secondary Timing, Voltage Scaling = VSCALE2

Parameter	Symbol	Test Condition	Min	Typ	Max	Unit
SCLK high time ^{1 2}	t_{SCLK_HI}		50	—	—	ns
SCLK low time ^{1 2}	t_{SCLK_LO}		50	—	—	ns
CS active to MISO ^{1 2}	$t_{CS_ACT_MI}$		5	—	56	ns
CS disable to MISO ^{1 2}	$t_{CS_DIS_MI}$		5	—	41	ns
MOSI setup time ^{1 2}	t_{SU_MO}		6	—	—	ns
MOSI hold time ^{1 2}	t_{H_MO}		8	—	—	ns
SCLK to MISO ^{1 2}	t_{SCLK_MI}	IOVDD = 1.8 V	9	—	41	ns
		IOVDD = 3.0 V	9	—	31	ns

Note:

1. Applies for both CLKPHA = 0 and CLKPHA = 1 (figure only shows CLKPHA = 0).
2. Measurement done with 15 pF output loading at 10% and 90% of V_{DD} (figure shows 50% of V_{DD}).

4.20.2 EUSART SPI Secondary Timing, Voltage Scaling = VSCALE1

Timing specifications are for all SPI signals routed to the same DBUS (DBUSAB or DBUSCD) on consecutive pins. All GPIO set to slew rate = 6.

Table 4.32. EUSART SPI Secondary Timing, Voltage Scaling = VSCALE1

Parameter	Symbol	Test Condition	Min	Typ	Max	Unit
SCLK high time ^{1 2}	t _{SCLK_HI}		50	—	—	ns
SCLK low time ^{1 2}	t _{SCLK_LO}		50	—	—	ns
CS active to MISO ^{1 2}	t _{CS_ACT_MI}		6	—	83	ns
CS disable to MISO ^{1 2}	t _{CS_DIS_MI}		6	—	65	ns
MOSI setup time ^{1 2}	t _{SU_MO}		9	—	—	ns
MOSI hold time ^{1 2}	t _{H_MO}		14	—	—	ns
SCLK to MISO ^{1 2}	t _{SCLK_MI}	IOVDD = 1.8 V	9	—	47	ns
		IOVDD = 3.0 V	9	—	38	ns
Note:						
1. Applies for both CLKPHA = 0 and CLKPHA = 1 (figure only shows CLKPHA = 0).						
2. Measurement done with 15 pF output loading at 10% and 90% of V _{DD} (figure shows 50% of V _{DD}).						

4.20.3 EUSART SPI Secondary Timing, Voltage Scaling = VSCALE0

Timing specifications at VSCALE0 apply to EUSART0 only, routed to DBUSAB on consecutive pins. All GPIO set to slew rate = 6.

Table 4.33. EUSART SPI Secondary Timing, Voltage Scaling = VSCALE0

Parameter	Symbol	Test Condition	Min	Typ	Max	Unit
SCLK high time ^{1 2}	t _{SCLK_HI}		100	—	—	ns
SCLK low time ^{1 2}	t _{SCLK_LO}		100	—	—	ns
CS active to MISO ^{1 2}	t _{CS_ACT_MI}		8	—	101	ns
CS disable to MISO ^{1 2}	t _{CS_DIS_MI}		7	—	68	ns
MOSI setup time ^{1 2}	t _{SU_MO}		10	—	—	ns
MOSI hold time ^{1 2}	t _{H_MO}		37	—	—	ns
SCLK to MISO ^{1 2}	t _{SCLK_MI}	IOVDD = 1.8 V	11	—	77	ns
		IOVDD = 3.0 V	11	—	70	ns
Note:						
1. Applies for both CLKPHA = 0 and CLKPHA = 1 (figure only shows CLKPHA = 0).						
2. Measurement done with 15 pF output loading at 10% and 90% of V _{DD} (figure shows 50% of V _{DD}).						

4.21 I2C Electrical Specifications

4.21.1 I2C Standard-mode (Sm)

CLHR set to 0 in the I2Cn_CTRL register.

Table 4.34. I2C Standard-mode (Sm)

Parameter	Symbol	Test Condition	Min	Typ	Max	Unit
SCL clock frequency ¹	f_{SCL}		0	—	100	kHz
SCL clock low time	t_{LOW}		4.7	—	—	μs
SCL clock high time	t_{HIGH}		4	—	—	μs
SDA set-up time	t_{SU_DAT}		250	—	—	ns
SDA hold time	t_{HD_DAT}		0	—	—	ns
Repeated START condition set-up time	t_{SU_STA}		4.7	—	—	μs
Repeated START condition hold time	t_{HD_STA}		4.0	—	—	μs
STOP condition set-up time	t_{SU_STO}		4.0	—	—	μs
Bus free time between a STOP and START condition	t_{BUF}		4.7	—	—	μs

Note:

1. The maximum SCL clock frequency listed is assuming that an arbitrary clock frequency is available. The maximum attainable SCL clock frequency may be slightly less using the HFXO or HFRCO due to the limited frequencies available. The CLKDIV should be set to a value that keeps the SCL clock frequency below the max value listed.

4.21.2 I2C Fast-mode (Fm)

CLHR set to 1 in the I2Cn_CTRL register.

Table 4.35. I2C Fast-mode (Fm)

Parameter	Symbol	Test Condition	Min	Typ	Max	Unit
SCL clock frequency ¹	f_{SCL}		0	—	400	kHz
SCL clock low time	t_{LOW}		1.3	—	—	μs
SCL clock high time	t_{HIGH}		0.6	—	—	μs
SDA set-up time	t_{SU_DAT}		100	—	—	ns
SDA hold time	t_{HD_DAT}		0	—	—	ns
Repeated START condition set-up time	t_{SU_STA}		0.6	—	—	μs
Repeated START condition hold time	t_{HD_STA}		0.6	—	—	μs
STOP condition set-up time	t_{SU_STO}		0.6	—	—	μs
Bus free time between a STOP and START condition	t_{BUF}		1.3	—	—	μs

Note:

1. The maximum SCL clock frequency listed is assuming that an arbitrary clock frequency is available. The maximum attainable SCL clock frequency may be slightly less using the HFXO or HFRCO due to the limited frequencies available. The CLKDIV should be set to a value that keeps the SCL clock frequency below the max value listed.

4.21.3 I2C Fast-mode Plus (Fm+)

CLHR set to 1 in the I2Cn_CTRL register.

Table 4.36. I2C Fast-mode Plus (Fm+)

Parameter	Symbol	Test Condition	Min	Typ	Max	Unit
SCL clock frequency ¹	f _{SCL}		0	—	1000	kHz
SCL clock low time	t _{LOW}		0.5	—	—	μs
SCL clock high time	t _{HIGH}		0.26	—	—	μs
SDA set-up time	t _{SU_DAT}		50	—	—	ns
SDA hold time	t _{HD_DAT}		0	—	—	ns
Repeated START condition set-up time	t _{SU_STA}		0.26	—	—	μs
Repeated START condition hold time	t _{HD_STA}		0.26	—	—	μs
STOP condition set-up time	t _{SU_STO}		0.26	—	—	μs
Bus free time between a STOP and START condition	t _{BUF}		0.5	—	—	μs

Note:

1. The maximum SCL clock frequency listed is assuming that an arbitrary clock frequency is available. The maximum attainable SCL clock frequency may be slightly less using the HF XO or HFRCO due to the limited frequencies available. The CLKDIV should be set to a value that keeps the SCL clock frequency below the max value listed.

4.22 Boot Timing

Secure boot impacts the recovery time from all sources of device reset. In addition to the root code authentication process, which cannot be disabled or bypassed, the root code can authenticate a bootloader, and the bootloader can authenticate the application. In projects that include only an application and no bootloader, the root code can authenticate the application directly. The duration of each authentication operation depends on two factors: the computation of the associated image hash, which is proportional to the size of the image, and the verification of the image signature, which is independent of image size.

The duration for the root code to authenticate the bootloader will depend on the SE firmware version as well as on the size of the bootloader.

The duration for the bootloader to authenticate the application can depend on the size of the application.

The configurations below assume that the associated bootloader and application code images do not contain a bootloader certificate or an application certificate. Authenticating a bootloader certificate or an application certificate will extend the boot time by an additional 6 to 7 ms.

The table below provides the durations from the termination of reset until the completion of the secure boot process (start of main() function in the application image) under various conditions.

Conditions:

- SE firmware version 2.1.5
- Gecko Bootloader size 10.2 KB

Timing is expected to be similar for subsequent SE firmware versions. Refer to SE firmware release notes for any significant changes.

Table 4.37. Boot Timing

Parameter	Symbol	Test Condition	Min	Typ	Max	Unit
Boot time	t _{BOOT}	Secure boot application check disabled, no bootloader	—	24.4	—	ms
		Secure boot application check disabled, second stage bootloader check enabled ¹ , 50 KB application size	—	32.3	—	ms
		Secure boot application check enabled, second stage bootloader check enabled ¹ , 50 KB application size	—	42.9	—	ms
		Secure boot application check enabled, second stage bootloader check enabled ¹ , 150 KB application size	—	45.6	—	ms
		Secure boot application check enabled, second stage bootloader check enabled ¹ , 350 KB application size	—	51.0	—	ms

Note:

1. Timing is measured with the specified bootloader size. Actual bootloader size will impact the boot timing slightly, with a similar $\mu\text{s} / \text{KB}$ ratio as application size.

4.23 Crypto Operation Timing for SE Manager API

Values in this table represent timing from SE Manager API call to return. The Cortex-M33 HCLK frequency is 39.0 MHz. The timing specifications below are measured at the SE Manager function call API. Each duration in the table contains some portion that is influenced by SE Manager build compilation and Cortex-M33 operating frequency and some portion that is influenced by the Hardware Secure Engine's firmware version and its operating speed (typically 80 MHz). The contributions of the Cortex-M33 properties to the overall specification timing are most pronounced for the shorter operations such as AES and hash when operating on small payloads. The overhead of command processing at the mailbox interface can also dominate the timing for shorter operations.

Conditions:

- SE firmware version 2.2.4
- GSDK version 4.4.0

Timing is expected to be similar for subsequent SE firmware versions. Refer to SE firmware release notes for any significant changes.

Table 4.38. Crypto Operation Timing for SE Manager API

Parameter	Symbol	Test Condition	Min	Typ	Max	Unit
AES-128 timing	t_{AES128}	AES-128 CCM encryption, PT 1 KB	—	578.83	—	μs
		AES-128 CCM encryption, PT 32 KB	—	1762.6	—	μs
		AES-128 CTR encryption, PT 1 KB	—	483	—	μs
		AES-128 CTR encryption, PT 32 KB	—	1049	—	μs
		AES-128 GCM encryption, PT 1 KB	—	529	—	μs
		AES-128 GCM encryption, PT 32 KB	—	1099	—	μs
AES-256 timing	t_{AES256}	AES-256 CCM encryption, PT 1 KB	—	593	—	μs
		AES-256 CCM encryption, PT 32 KB	—	2194	—	μs
		AES-256 CTR encryption, PT 1 KB	—	488	—	μs
		AES-256 CTR encryption, PT 32 KB	—	1262	—	μs
		AES-256 GCM encryption, PT 1 KB	—	537	—	μs
		AES-256 GCM encryption, PT 32 KB	—	1312	—	μs
ECC P-256 timing	t_{ECC_P256}	ECC key generation, P-256	—	5.5	—	ms
		ECC signing, P-256	—	5.8	—	ms
		ECC verification, P-256	—	6.2	—	ms
ECC P-521 timing ¹	t_{ECC_P521}	ECC key generation, P-521	—	30.3	—	ms
		ECC signing, P-521	—	31.1	—	ms
		ECC verification, P-521	—	36.3	—	ms

Parameter	Symbol	Test Condition	Min	Typ	Max	Unit
ECC P-25519 timing	t _{ECC_P25519}	ECC key generation, P-25519	—	4.5	—	ms
		ECC signing, P-25519	—	8.9	—	ms
		ECC verification, P-25519	—	6.3	—	ms
ECDH compute secret timing	t _{ECDH}	ECDH compute secret, P-521 ¹	—	30.6	—	ms
		ECDH compute secret, P-25519	—	4.5	—	ms
		ECDH compute secret, P-256	—	5.6	—	ms
ECJPAKE client timing	t _{ECJPAKE_C}	ECJPAKE client write round one	—	21.6	—	ms
		ECJPAKE client read round one	—	11.8	—	ms
		ECJPAKE client write round two	—	15.4	—	ms
		ECJPAKE client read round two	—	6.4	—	ms
		ECJPAKE client derive secret	—	8.9	—	ms
ECJPAKE server timing	t _{ECJPAKE_S}	ECJPAKE server write round one	—	21.5	—	ms
		ECJPAKE server read round one	—	11.8	—	ms
		ECJPAKE server write round two	—	15.4	—	ms
		ECJPAKE server read round two	—	6.4	—	ms
		ECJPAKE server derive secret	—	8.9	—	ms
POLY-1305 timing ¹	t _{POLY1305}	POLY-1305, PT 1 KB	—	517	—	μs
		POLY-1305, PT 32 KB	—	1185	—	μs
SHA-256 timing	t _{SHA256}	SHA-256, PT 1 KB	—	315	—	μs
		SHA-256, PT 32 KB	—	739	—	μs
SHA-512 timing ¹	t _{SHA512}	SHA-512, PT 1 KB	—	312	—	μs
		SHA-512, PT 32 KB	—	626	—	μs

Note:

1. Option is only available on OPNs with Secure Vault High feature set.

4.24 Crypto Operation Average Current for SE Manager API

Values in this table represent current consumed by security core during the operation, and represent additions to the current consumed by the Cortex-M33 application CPU due to the Hardware Secure Engine CPU and its associated crypto accelerators. The current measurements below represent the average value of the current for the duration of the crypto operation. Instantaneous peak currents may be higher.

Conditions:

- SE firmware version 2.2.4
- GSDK version 4.4.0

Current consumption is expected to be similar for subsequent SE firmware versions. Refer to SE firmware release notes for any significant changes.

Table 4.39. Crypto Operation Average Current for SE Manager API

Parameter	Symbol	Test Condition	Min	Typ	Max	Unit
AES-128 current	I _{AES128}	AES-128 CCM encryption, PT 1 KB	—	1.0	—	mA
		AES-128 CCM encryption, PT 32 KB	—	3.6	—	mA
		AES-128 CTR encryption, PT 1 KB	—	0.9	—	mA
		AES-128 CTR encryption, PT 32 KB	—	3.6	—	mA
		AES-128 GCM encryption, PT 1 KB	—	0.9	—	mA
		AES-128 GCM encryption, PT 32 KB	—	3.6	—	mA
AES-256 current	I _{AES256}	AES-256 CCM encryption, PT 1 KB	—	1.1	—	mA
		AES-256 CCM encryption, PT 32 KB	—	3.7	—	mA
		AES-256 CTR encryption, PT 1 KB	—	0.9	—	mA
		AES-256 CTR encryption, PT 32 KB	—	3.7	—	mA
		AES-256 GCM encryption, PT 1 KB	—	0.9	—	mA
		AES-256 GCM encryption, PT 32 KB	—	3.7	—	mA
ECC P-256 current	I _{ECCP256}	ECC key generation, P-256	—	1.7	—	mA
		ECC signing, P-256	—	1.7	—	mA
		ECC verification, P-256	—	1.7	—	mA
ECC P-521 current ¹	I _{ECCP521}	ECC key generation, P-521	—	1.8	—	mA
		ECC signing, P-521	—	1.9	—	mA
		ECC verification, P-521	—	1.9	—	mA

Parameter	Symbol	Test Condition	Min	Typ	Max	Unit
ECC P-25519 current	I _{ECCP25519}	ECC key generation, P-25519	—	1.6	—	mA
		ECC signing, P-25519	—	1.7	—	mA
		ECC verification, P-25519	—	1.7	—	mA
ECDH compute secret current	I _{ECDH}	ECDH compute secret, P-521 ¹	—	1.8	—	mA
		ECDH compute secret, P-25519	—	1.6	—	mA
		ECDH compute secret, P-256	—	1.7	—	mA
ECJPAKE client current	I _{ECJPAKE_C}	ECJPAKE client write round one	—	1.7	—	mA
		ECJPAKE client read round one	—	1.7	—	mA
		ECJPAKE client write round two	—	1.7	—	mA
		ECJPAKE client read round two	—	1.7	—	mA
		ECJPAKE client derive secret	—	1.7	—	mA
ECJPAKE server current	I _{ECJPAKE_S}	ECJPAKE server write round one	—	1.7	—	mA
		ECJPAKE server read round one	—	1.7	—	mA
		ECJPAKE server write round two	—	1.7	—	mA
		ECJPAKE server read round two	—	1.7	—	mA
		ECJPAKE server derive secret	—	1.7	—	mA
POLY-1305 current ¹	I _{POLY1305}	POLY-1305, PT 1 KB	—	0.8	—	mA
		POLY-1305, PT 32 KB	—	1.7	—	mA
SHA-256 current	I _{SHA256}	SHA-256, PT 1 KB	—	0.8	—	mA
		SHA-256, PT 32 KB	—	2.4	—	mA
SHA-512 current ¹	I _{SHA512}	SHA-512, PT 1 KB	—	0.8	—	mA
		SHA-512, PT 32 KB	—	2.0	—	mA

Note:

1. Option is only available on OPNs with Secure Vault High feature set.

4.25 Matrix Vector Processor (MVP)

All measurements are in comparison to EM1 baseline current at given VSCALE and Clock settings. Matrix dimensions are X = 24 x 32, Y = 32 x 24 and Z = 24 x 24.

Table 4.40. Matrix Vector Processor (MVP)

Parameter	Symbol	Test Condition	Min	Typ	Max	Unit
MVP Enable Current	I _{EN}	VSCALE1, HFXO @ 39 MHz	—	16.8	—	μA
		VSCALE2, HFRCO w/ DPLL @ 78 MHz	—	41.2	—	μA
Matrix Multiplication Duration using MVP Hardware	T _{MVP_MULTIPLY}	16-bit complex numbers, fully banked memory, VSCALE1, HFXO @ 39 MHz	—	504.0	—	μs
		16-bit complex numbers, fully banked memory, VSCALE2, HFRCO w/ DPLL @ 78 MHz	—	252.0	—	μs
		16-bit complex numbers, interleaved memory, VSCALE1, HFXO @ 39 MHz	—	596.2	—	μs
		16-bit complex numbers, interleaved memory, VSCALE2, HFRCO w/ DPLL @ 78 MHz	—	298.2	—	μs
Matrix Multiplication Duration using Software	T _{SW_MULTIPLY}	16-bit complex numbers, interleaved memory, VSCALE1, HFXO @ 39 MHz	—	41.0	—	ms
		16-bit complex numbers, interleaved memory, VSCALE2, HFRCO w/ DPLL @ 78 MHz	—	20.5	—	ms
		32-bit complex numbers, interleaved memory, VSCALE1, HFXO @ 39 MHz	—	19.7	—	ms
		32-bit complex numbers, interleaved memory, VSCALE2, HFRCO w/ DPLL @ 78 MHz	—	9.9	—	ms
Matrix Multiplication Current using MVP Hardware	I _{MVP_MULTIPLY}	16-bit complex numbers, fully banked memory, VSCALE1, HFXO @ 39 MHz	—	61.3	—	μA/MHz
		16-bit complex numbers, fully banked memory, VSCALE2, HFRCO w/ DPLL @ 78 MHz	—	62.4	—	μA/MHz
		16-bit complex numbers, interleaved memory, VSCALE1, HFXO @ 39 MHz	—	53.2	—	μA/MHz
		16-bit complex numbers, interleaved memory, VSCALE2, HFRCO w/ DPLL @ 78 MHz	—	53.8	—	μA/MHz

Parameter	Symbol	Test Condition	Min	Typ	Max	Unit
Matrix Multiplication Current using Software	I _{SW_MULTIPLY}	16-bit complex numbers, interleaved memory, VSCALE1, HFXO @ 39 MHz	—	41.7	—	μA/MHz
		16-bit complex numbers, interleaved memory, VSCALE2, HFRCO w/ DPLL @ 78 MHz	—	44.7	—	μA/MHz
		32-bit complex numbers, interleaved memory, VSCALE1, HFXO @ 39 MHz	—	31.9	—	μA/MHz
		32-bit complex numbers, interleaved memory, VSCALE2, HFRCO w/ DPLL @ 78 MHz	—	33.8	—	μA/MHz

4.26 LCD

Table 4.41. LCD

Parameter	Symbol	Test Condition	Min	Typ	Max	Unit
LCD Temperature Range	T _{RANGE}		-40	—	105	°C
Frame rate	f _{LCDFR}		30	—	100	Hz
LCD supply range ^{1 2}	V _{LCDIN}		1.71	—	3.8	V
LCD output voltage range ²	V _{LCD}	Step-down mode with external LCD capacitor	2.4	—	MIN(3.6, V _{LCDIN} - 0.1)	V
		Charge pump mode with external LCD capacitor	2.4	—	MIN(3.6, 1.9 * V _{LCDIN})	V
Contrast control step size	STEP _{CONTRAST}	Charge pump or Step-down mode	—	50	—	mV
Contrast control step accuracy ³	ACC _{CONTRAST}		—	+/- 1.5	—	%

Note:

- V_{LCDIN} is selectable between the AVDD or DVDD supply pins, depending on EMU_PWRCTRL_ANASW.
- V_{LCDIN} and V_{LCD} should be a maximum of 2 V above V_{IOVDD} to avoid additional leakage through the GPIO pins used for LCD functions.
- Step size accuracy is measured relative to the typical step size, and typ value represents one standard deviation.

4.27 Typical Performance Curves

Typical performance curves indicate typical characterized performance under the stated conditions.

4.27.1 Supply Current

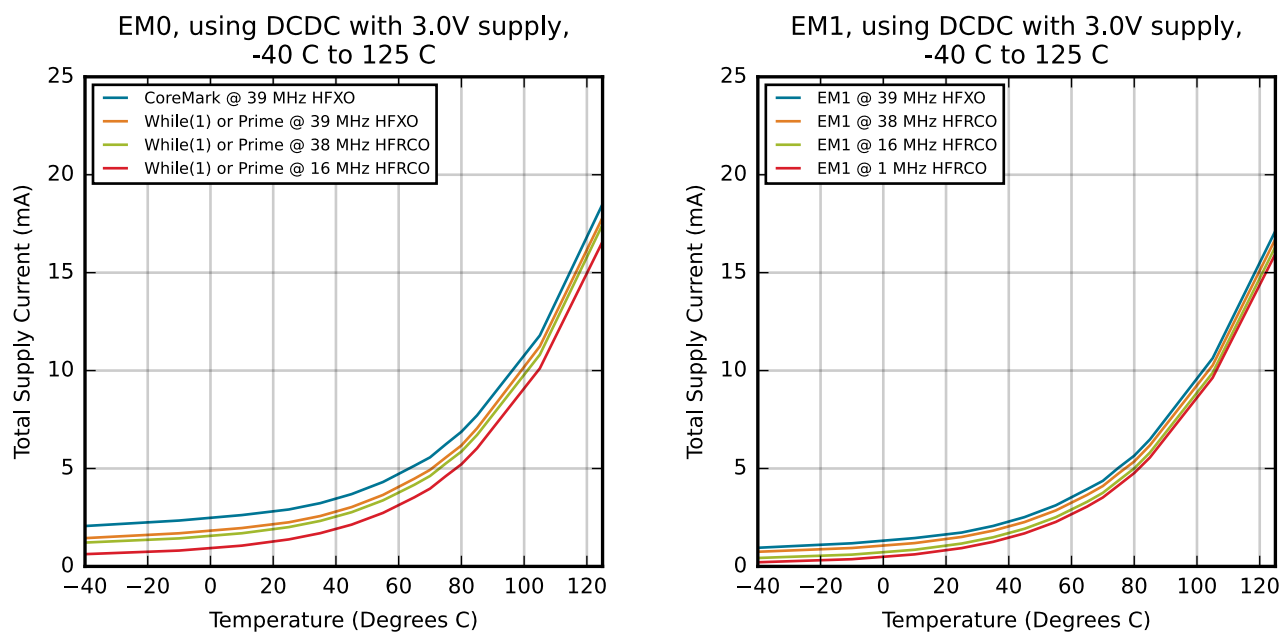

Figure 4.9. EM0 and EM1 Typical Supply Current vs. Temperature

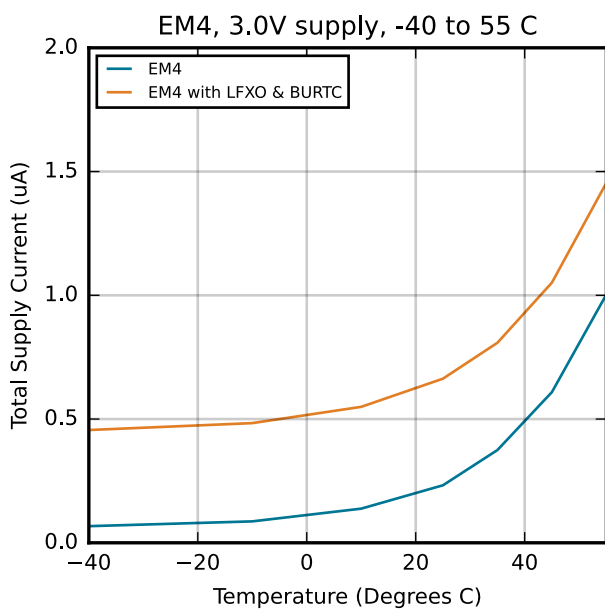
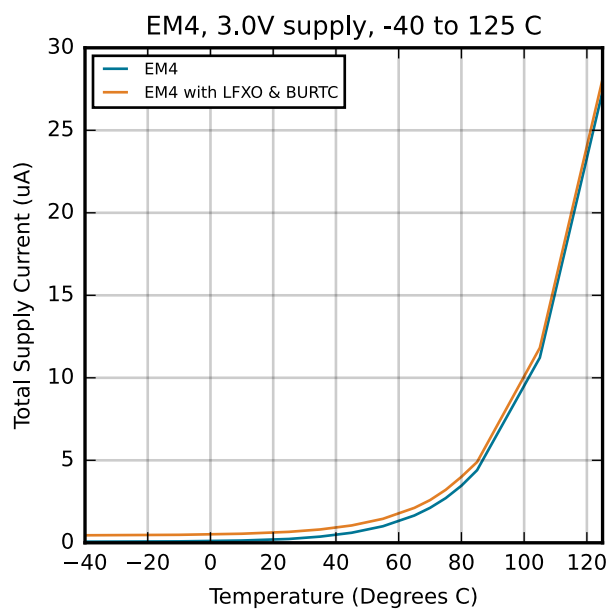
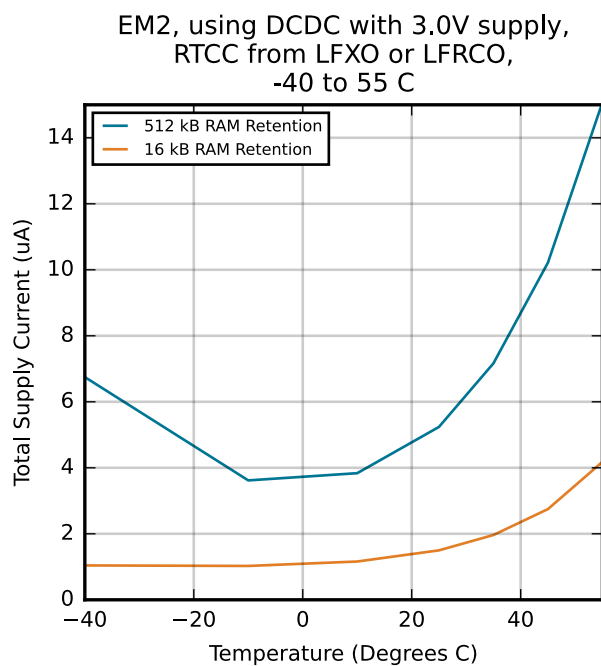
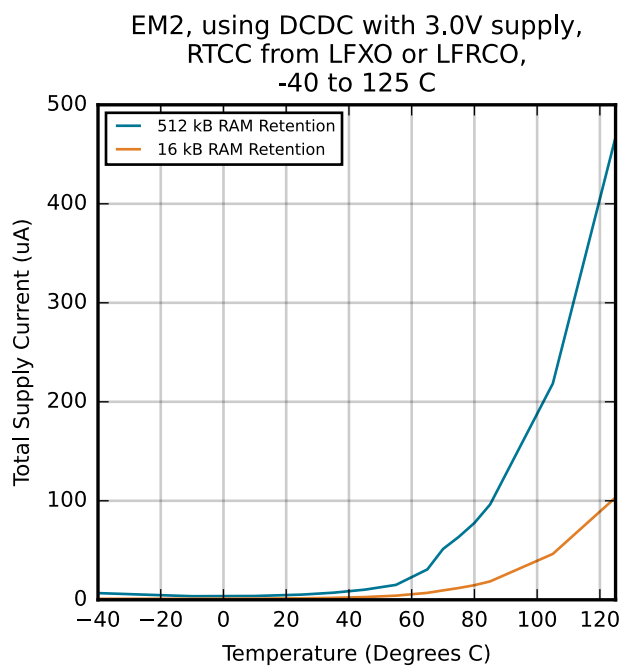

Figure 4.10. EM2 and EM4 Typical Supply Current vs. Temperature

4.27.2 DC-DC Converter

Performance characterized with Murata DFE2HCAH2R2MJ0 ($L_{DCDC} = 2.2 \mu\text{H}$) and TDK CGA5L3X8R1C475K160AB ($C_{DCDC} = 4.7 \mu\text{F}$)

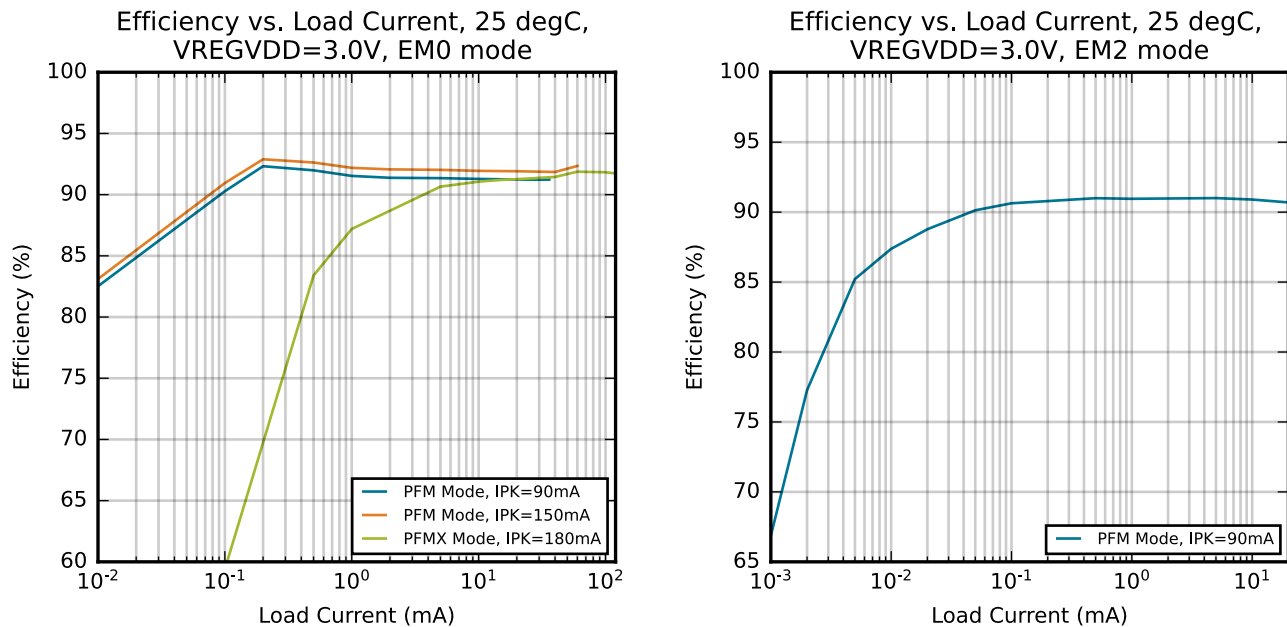

Figure 4.11. DC-DC Efficiency

4.27.4 GPIO

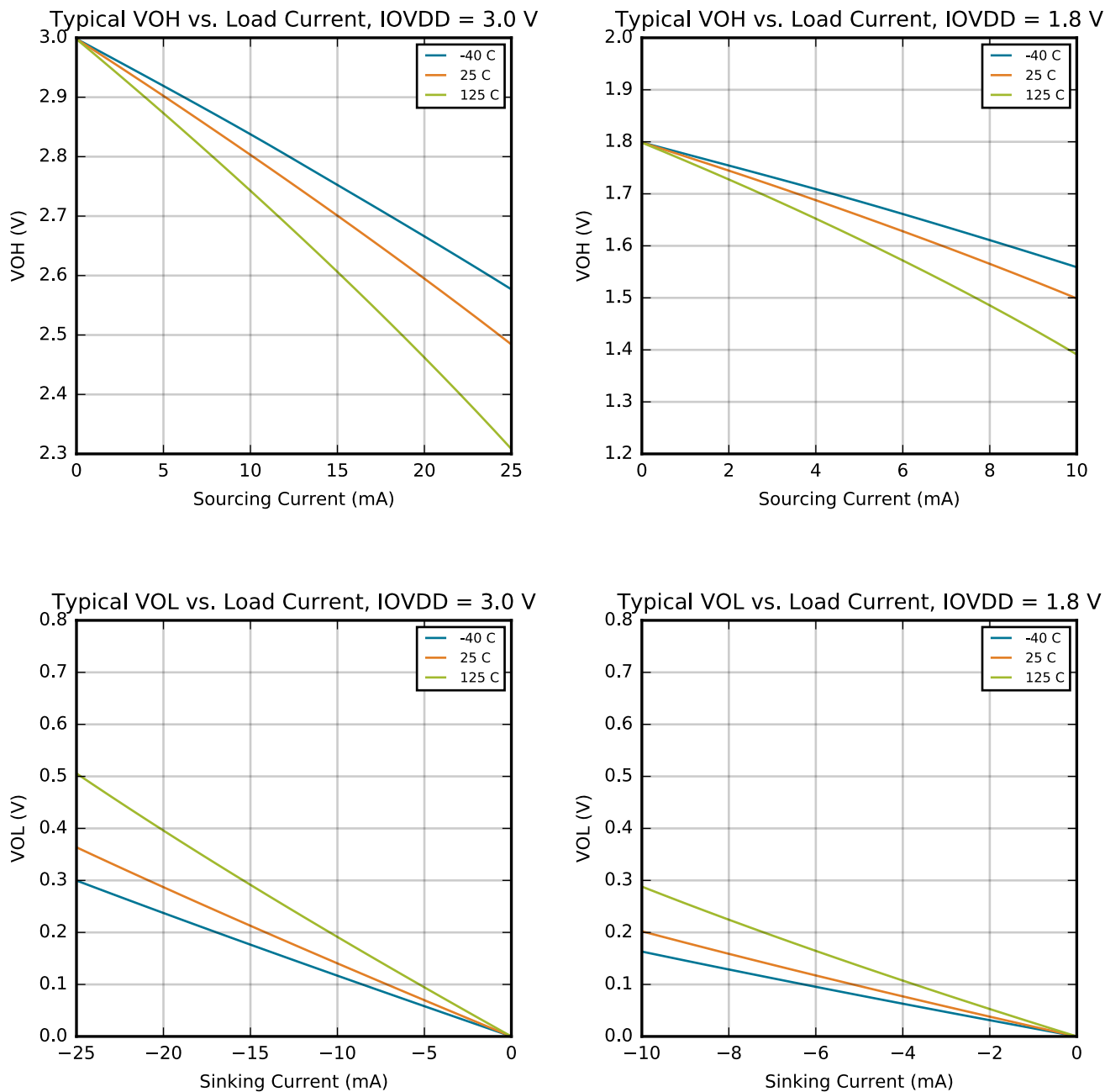

Figure 4.12. VOH and VOL vs. Load Current

5. Typical Connections

5.1 Power

Typical power supply connections are shown in the following figures.

Note: AVDD and IOVDD supply connections are flexible. They may be connected in other configurations or to external supplies as long as the supply limits described in [4.1 Electrical Characteristics](#) are met.

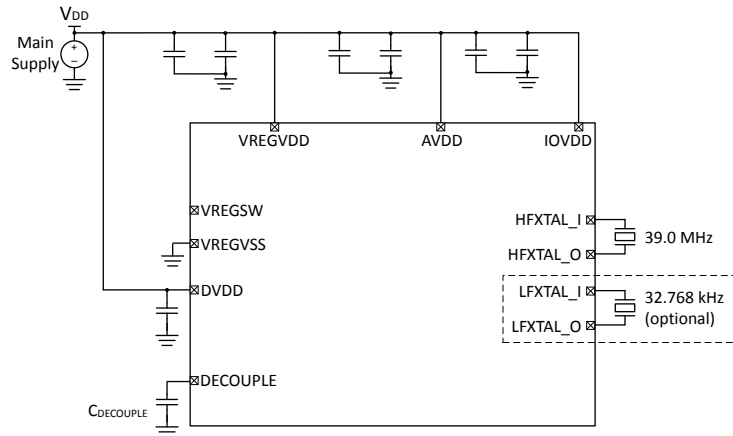

Figure 5.1. EFM32PG26 Typical Application Circuit: Direct Supply Configuration without DCDC

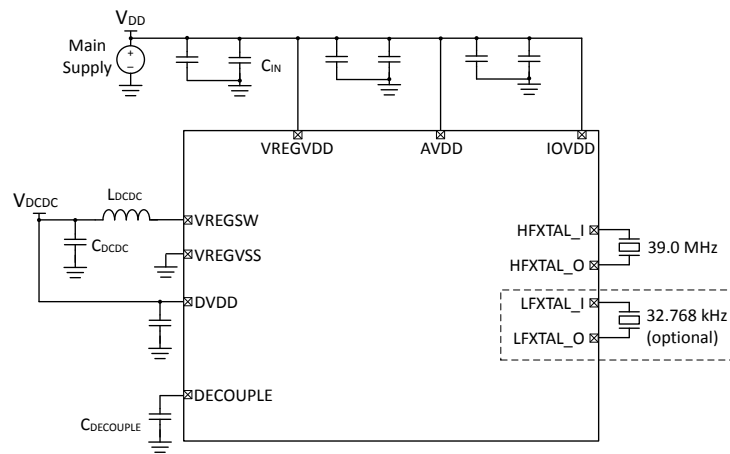

Figure 5.2. EFM32PG26 Typical Application Circuit: DCDC Configuration, AVDD and IOVDD from main supply

6. Pin Definitions

6.1 BGA136 / MCU Device Pinout

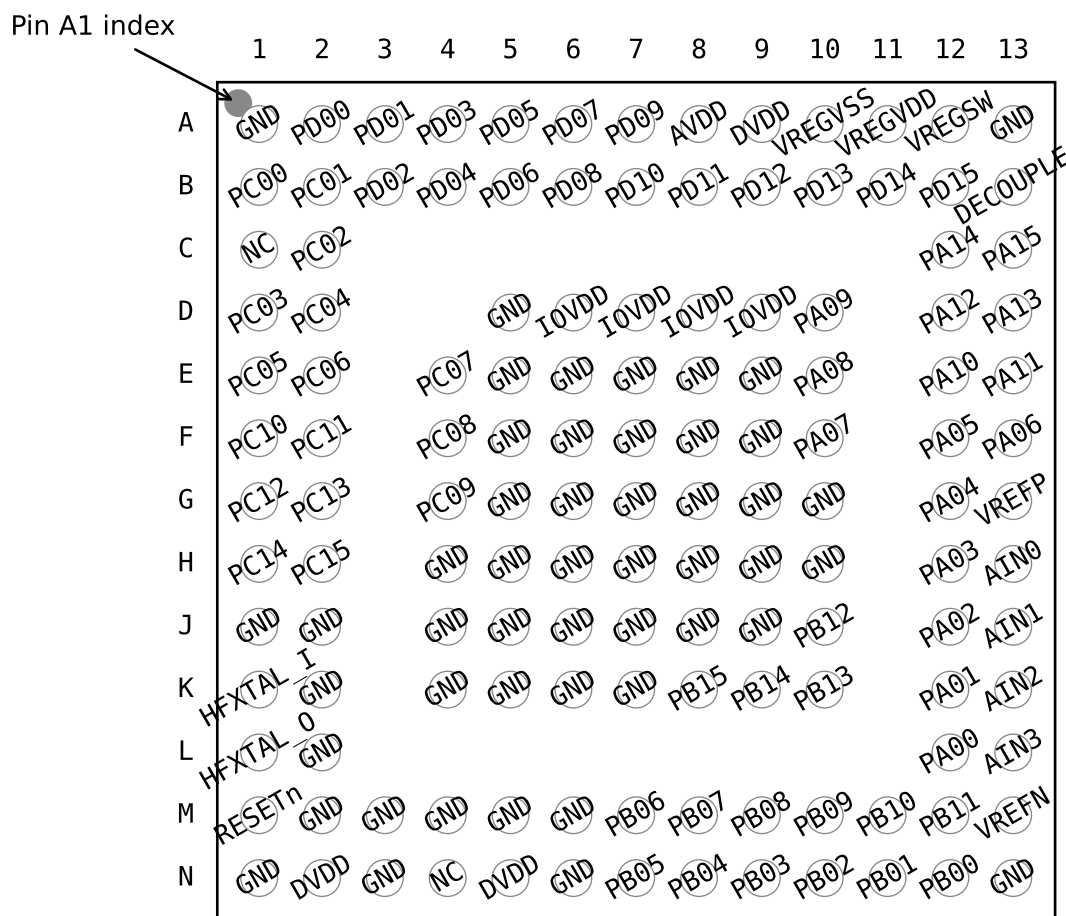

Figure 6.1. BGA136 / MCU Device Pinout

The following table provides package pin connections and general descriptions of pin functionality. For detailed information on the supported features for each GPIO pin, see [6.4 Alternate Function Table](#), [6.5 Analog Peripheral Connectivity](#), and [6.6 Digital Peripheral Connectivity](#).

Table 6.1. BGA136 / MCU Device Pinout

Pin Name	Pin(s)	Description	Pin Name	Pin(s)	Description
GND	A1	Ground	PD00	A2	GPIO
PD01	A3	GPIO	PD03	A4	GPIO
PD05	A5	GPIO	PD07	A6	GPIO
PD09	A7	GPIO	AVDD	A8	Analog power supply
DVDD	A9	Digital power supply	VREGVSS	A10	DCDC ground

Pin Name	Pin(s)	Description	Pin Name	Pin(s)	Description
VREGVDD	A11	DCDC regulator input supply	VREGSW	A12	DCDC regulator switching node
GND	A13	Ground	PC00	B1	GPIO
PC01	B2	GPIO	PD02	B3	GPIO
PD04	B4	GPIO	PD06	B5	GPIO
PD08	B6	GPIO	PD10	B7	GPIO
PD11	B8	GPIO	PD12	B9	GPIO
PD13	B10	GPIO	PD14	B11	GPIO
PD15	B12	GPIO	DECOUPLE	B13	Decouple output for on-chip voltage regulator. An external decoupling capacitor is required at this pin.
NC	C1	No connect	PC02	C2	GPIO
PA14	C12	GPIO	PA15	C13	GPIO
PC03	D1	GPIO	PC04	D2	GPIO
GND	D5	Ground	IOVDD	D6	I/O power supply
IOVDD	D7	I/O power supply	IOVDD	D8	I/O power supply
IOVDD	D9	I/O power supply	PA09	D10	GPIO
PA12	D12	GPIO	PA13	D13	GPIO
PC05	E1	GPIO	PC06	E2	GPIO
PC07	E4	GPIO	GND	E5	Ground
GND	E6	Ground	GND	E7	Ground
GND	E8	Ground	GND	E9	Ground
PA08	E10	GPIO	PA10	E12	GPIO
PA11	E13	GPIO	PC10	F1	GPIO
PC11	F2	GPIO	PC08	F4	GPIO
GND	F5	Ground	GND	F6	Ground
GND	F7	Ground	GND	F8	Ground
GND	F9	Ground	PA07	F10	GPIO
PA05	F12	GPIO	PA06	F13	GPIO
PC12	G1	GPIO	PC13	G2	GPIO
PC09	G4	GPIO	GND	G5	Ground
GND	G6	Ground	GND	G7	Ground
GND	G8	Ground	GND	G9	Ground
GND	G10	Ground	PA04	G12	GPIO
VREFP	G13	Dedicated ADC VREF Positive Input	PC14	H1	GPIO
PC15	H2	GPIO	GND	H4	Ground
GND	H5	Ground	GND	H6	Ground
GND	H7	Ground	GND	H8	Ground
GND	H9	Ground	GND	H10	Ground

Pin Name	Pin(s)	Description	Pin Name	Pin(s)	Description
PA03	H12	GPIO	AIN0	H13	Dedicated ADC Input 0
GND	J1	Ground	GND	J2	Ground
GND	J4	Ground	GND	J5	Ground
GND	J6	Ground	GND	J7	Ground
GND	J8	Ground	GND	J9	Ground
PB12	J10	GPIO	PA02	J12	GPIO
AIN1	J13	Dedicated ADC Input 1	HFXTAL_I	K1	High Frequency Crystal Input
GND	K2	Ground	GND	K4	Ground
GND	K5	Ground	GND	K6	Ground
GND	K7	Ground	PB15	K8	GPIO
PB14	K9	GPIO	PB13	K10	GPIO
PA01	K12	GPIO	AIN2	K13	Dedicated ADC Input 2
HFXTAL_O	L1	High Frequency Crystal Output	GND	L2	Ground
PA00	L12	GPIO	AIN3	L13	Dedicated ADC Input 3
RESETn	M1	Reset Pin. The RESETn pin is internally pulled up to DVDD.	GND	M2	Ground
GND	M3	Ground	GND	M4	Ground
GND	M5	Ground	GND	M6	Ground
PB06	M7	GPIO	PB07	M8	GPIO
PB08	M9	GPIO	PB09	M10	GPIO
PB10	M11	GPIO	PB11	M12	GPIO
VREFN	M13	Dedicated ADC VREF Negative Input	GND	N1	Ground
DVDD	N2	Digital power supply	GND	N3	Ground
NC	N4	No Connect	DVDD	N5	Digital power supply
GND	N6	Ground	PB05	N7	GPIO
PB04	N8	GPIO	PB03	N9	GPIO
PB02	N10	GPIO	PB01	N11	GPIO
PB00	N12	GPIO	GND	N13	Ground

6.2 QFN68 / MCU Device Pinout

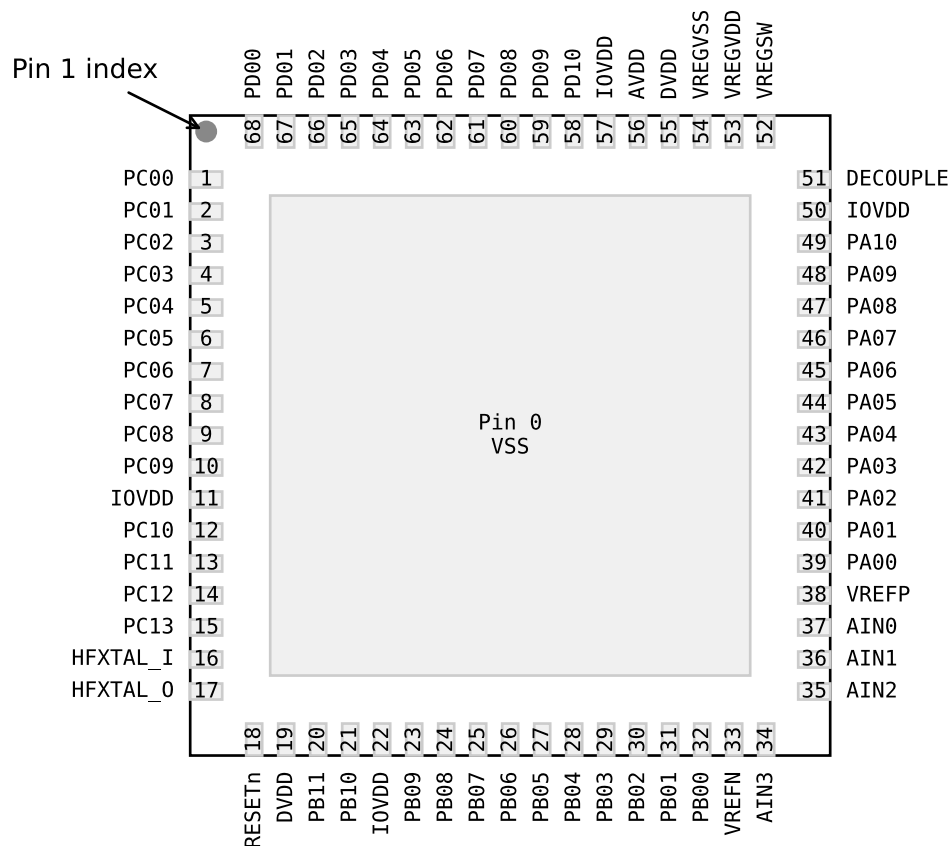

Figure 6.2. QFN68 / MCU Device Pinout

The following table provides package pin connections and general descriptions of pin functionality. For detailed information on the supported features for each GPIO pin, see [6.4 Alternate Function Table](#), [6.5 Analog Peripheral Connectivity](#), and [6.6 Digital Peripheral Connectivity](#).

Table 6.2. QFN68 / MCU Device Pinout

Pin Name	Pin(s)	Description	Pin Name	Pin(s)	Description
PC00	1	GPIO	PC01	2	GPIO
PC02	3	GPIO	PC03	4	GPIO
PC04	5	GPIO	PC05	6	GPIO
PC06	7	GPIO	PC07	8	GPIO
PC08	9	GPIO	PC09	10	GPIO
IOVDD	11	I/O power supply	PC10	12	GPIO
PC11	13	GPIO	PC12	14	GPIO

Pin Name	Pin(s)	Description	Pin Name	Pin(s)	Description
PC13	15	GPIO	HFXTAL_I	16	High Frequency Crystal Input
HFXTAL_O	17	High Frequency Crystal Output	RESETn	18	Reset Pin. The RESETn pin is internally pulled up to DVDD.
DVDD	19	Digital power supply	PB11	20	GPIO
PB10	21	GPIO	IOVDD	22	I/O power supply
PB09	23	GPIO	PB08	24	GPIO
PB07	25	GPIO	PB06	26	GPIO
PB05	27	GPIO	PB04	28	GPIO
PB03	29	GPIO	PB02	30	GPIO
PB01	31	GPIO	PB00	32	GPIO
VREFN	33	Dedicated ADC VREF Negative Input	AIN3	34	Dedicated ADC Input 3
AIN2	35	Dedicated ADC Input 2	AIN1	36	Dedicated ADC Input 1
AIN0	37	Dedicated ADC Input 0	VREFP	38	Dedicated ADC VREF Positive Input
PA00	39	GPIO	PA01	40	GPIO
PA02	41	GPIO	PA03	42	GPIO
PA04	43	GPIO	PA05	44	GPIO
PA06	45	GPIO	PA07	46	GPIO
PA08	47	GPIO	PA09	48	GPIO
PA10	49	GPIO	IOVDD	50	I/O power supply
DECOUPLE	51	Decouple output for on-chip voltage regulator. An external decoupling capacitor is required at this pin.	VREGSW	52	DCDC regulator switching node
VREGVDD	53	DCDC regulator input supply	VREGVSS	54	DCDC ground
DVDD	55	Digital power supply	AVDD	56	Analog power supply
IOVDD	57	I/O power supply	PD10	58	GPIO
PD09	59	GPIO	PD08	60	GPIO
PD07	61	GPIO	PD06	62	GPIO
PD05	63	GPIO	PD04	64	GPIO
PD03	65	GPIO	PD02	66	GPIO
PD01	67	GPIO	PD00	68	GPIO

6.3 QFN48 / MCU Device Pinout

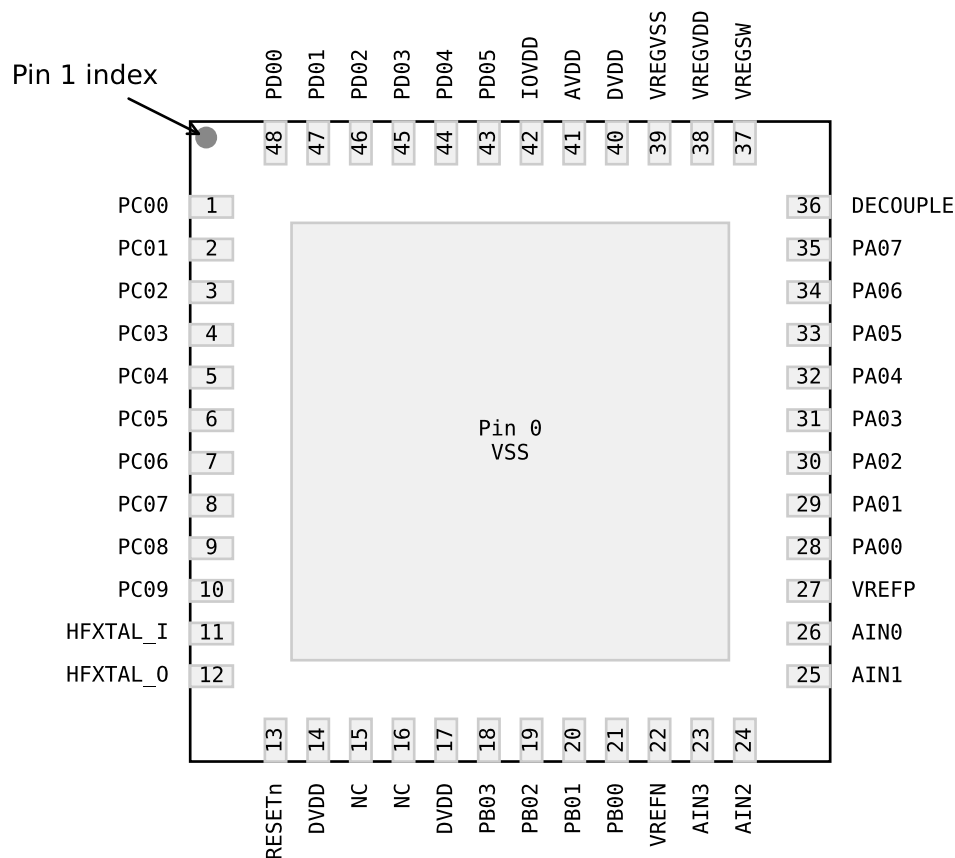

Figure 6.3. QFN48 / MCU Device Pinout

The following table provides package pin connections and general descriptions of pin functionality. For detailed information on the supported features for each GPIO pin, see [6.4 Alternate Function Table](#), [6.5 Analog Peripheral Connectivity](#), and [6.6 Digital Peripheral Connectivity](#).

Table 6.3. QFN48 / MCU Device Pinout

Pin Name	Pin(s)	Description	Pin Name	Pin(s)	Description
PC00	1	GPIO	PC01	2	GPIO
PC02	3	GPIO	PC03	4	GPIO
PC04	5	GPIO	PC05	6	GPIO
PC06	7	GPIO	PC07	8	GPIO
PC08	9	GPIO	PC09	10	GPIO
HFXTAL_I	11	High Frequency Crystal Input	HFXTAL_O	12	High Frequency Crystal Output

Pin Name	Pin(s)	Description	Pin Name	Pin(s)	Description
RESETn	13	Reset Pin. The RESETn pin is internally pulled up to DVDD.	DVDD	14	Digital power supply
NC	15	NC	NC	16	NC
DVDD	17	Digital power supply	PB03	18	GPIO
PB02	19	GPIO	PB01	20	GPIO
PB00	21	GPIO	VREFN	22	Dedicated ADC VREF Negative Input
AIN3	23	Dedicated ADC Input 3	AIN2	24	Dedicated ADC Input 2
AIN1	25	Dedicated ADC Input 1	AIN0	26	Dedicated ADC Input 0
VREFP	27	Dedicated ADC VREF Positive Input	PA00	28	GPIO
PA01	29	GPIO	PA02	30	GPIO
PA03	31	GPIO	PA04	32	GPIO
PA05	33	GPIO	PA06	34	GPIO
PA07	35	GPIO	DECOUPLE	36	Decouple output for on-chip voltage regulator. An external decoupling capacitor is required at this pin.
VREGSW	37	DCDC regulator switching node	VREGVDD	38	DCDC regulator input supply
VREGVSS	39	DCDC ground	DVDD	40	Digital power supply
AVDD	41	Analog power supply	IOVDD	42	I/O power supply
PD05	43	GPIO	PD04	44	GPIO
PD03	45	GPIO	PD02	46	GPIO
PD01	47	GPIO	PD00	48	GPIO

6.4 Alternate Function Table

A wide selection of alternate functionality is available for multiplexing to various pins. The following table shows GPIO pins with support for dedicated functions across the different package options.

Table 6.4. GPIO Alternate Function Table

GPIO	Alternate Functions	BGA136 / MCU Package ¹	QFN68 / MCU Package ²	QFN48 / MCU Package ³
PA00	LCD.SEG8	Yes	Yes	Yes
PA01	GPIO.SWCLK	Yes	Yes	Yes
	LCD.SEG9	Yes	Yes	Yes
PA02	GPIO.SWDIO	Yes	Yes	Yes
PA03	GPIO.SWV	Yes	Yes	Yes
	GPIO.TDO	Yes	Yes	Yes
	GPIO.TRACEDATA0	Yes	Yes	Yes
PA04	GPIO.TDI	Yes	Yes	Yes
	GPIO.TRACECLK	Yes	Yes	Yes
	LCD.SEG10	Yes	Yes	Yes
PA05	GPIO.TRACEDATA1	Yes	Yes	Yes
	GPIO.EM4WU0	Yes	Yes	Yes
	LCD.SEG11	Yes	Yes	Yes
PA06	GPIO.TRACEDATA2	Yes	Yes	Yes
	LCD.LCD_CP	Yes	Yes	Yes
PA07	GPIO.TRACEDATA3	Yes	Yes	Yes
	LCD.SEG12	Yes	Yes	Yes
PA08	LCD.SEG13	Yes	Yes	
PA09	LCD.SEG20	Yes	Yes	
PA10	LCD.SEG21	Yes	Yes	
PA11	LCD.SEG22	Yes		
PA12	LCD.SEG23	Yes		
PA13	LCD.SEG24	Yes		
PA14	LCD.SEG25	Yes		
PB00	LCD.SEG14	Yes	Yes	Yes
	VDAC0.CH0_MAIN_OUT	Yes	Yes	Yes
PB01	GPIO.EM4WU3	Yes	Yes	Yes
	LCD.SEG15	Yes	Yes	Yes
	VDAC0.CH1_MAIN_OUT	Yes	Yes	Yes
PB02	LCD.SEG16	Yes	Yes	Yes
	VDAC1.CH0_MAIN_OUT	Yes	Yes	Yes

GPIO	Alternate Functions	BGA136 / MCU Package ¹	QFN68 / MCU Package ²	QFN48 / MCU Package ³
PB03	GPIO.EM4WU4	Yes	Yes	Yes
	LCD.SEG17	Yes	Yes	Yes
	VDAC1.CH1_MAIN_OUT	Yes	Yes	Yes
PB04	LCD.SEG26	Yes	Yes	
PB05	LCD.SEG27	Yes	Yes	
PB06	LCD.SEG34	Yes	Yes	
PB07	LCD.SEG35	Yes	Yes	
PB08	LCD.COM4	Yes	Yes	
	LCD.SEG36	Yes	Yes	
PB09	LCD.COM5	Yes	Yes	
	LCD.SEG37	Yes	Yes	
PB10	LCD.COM6	Yes	Yes	
	LCD.SEG38	Yes	Yes	
PB11	LCD.COM7	Yes	Yes	
	LCD.SEG39	Yes	Yes	
PC00	GPIO.EM4WU6	Yes	Yes	Yes
	LCD.SEG0	Yes	Yes	Yes
PC01	GPIO.EFP_TX_SDA	Yes	Yes	Yes
	LCD.SEG1	Yes	Yes	Yes
PC02	GPIO.EFP_TX_SCL	Yes	Yes	Yes
	LCD.SEG2	Yes	Yes	Yes
PC03	LCD.SEG3	Yes	Yes	Yes
PC04	LCD.SEG4	Yes	Yes	Yes
PC05	GPIO.EFP_INT	Yes	Yes	Yes
	GPIO.EM4WU7	Yes	Yes	Yes
	LCD.SEG5	Yes	Yes	Yes
PC06	LCD.SEG6	Yes	Yes	Yes
PC07	GPIO.EM4WU8	Yes	Yes	Yes
	LCD.SEG7	Yes	Yes	Yes
PC08	LCD.SEG18	Yes	Yes	Yes
PC09	GPIO.THMSW_EN	Yes	Yes	Yes
	GPIO.THMSW_HALFSWITCH	Yes	Yes	Yes
	LCD.SEG19	Yes	Yes	Yes
PD00	LFXO.LFXTAL_O	Yes	Yes	Yes
PD01	LFXO.LFXTAL_I	Yes	Yes	Yes
	LFXO.LF_EXTCLK	Yes	Yes	Yes

GPIO	Alternate Functions	BGA136 / MCU Package ¹	QFN68 / MCU Package ²	QFN48 / MCU Package ³
PD02	GPIO.EM4WU9	Yes	Yes	Yes
	LCD.COM0	Yes	Yes	Yes
PD03	LCD.COM1	Yes	Yes	Yes
PD04	LCD.COM2	Yes	Yes	Yes
PD05	GPIO.EM4WU10	Yes	Yes	Yes
	LCD.COM3	Yes	Yes	Yes
PD06	LCD.SEG28	Yes	Yes	
PD07	LCD.SEG29	Yes	Yes	
PD08	LCD.SEG30	Yes	Yes	
PD09	LCD.SEG31	Yes	Yes	
PD10	LCD.SEG32	Yes	Yes	
PD11	LCD.SEG33	Yes		

Note:

1. BGA136 / MCU Package includes OPNs EFM32PG26B101F512IL136-B, EFM32PG26B301F1024IL136-B, EFM32PG26B301F2048IL136-B, EFM32PG26B500F3200IL136-B, and EFM32PG26B501F3200IL136-B
2. QFN68 / MCU Package includes OPNs EFM32PG26B101F512IM68-B, EFM32PG26B301F1024IM68-B, EFM32PG26B301F2048IM68-B, EFM32PG26B500F3200IM68-B, and EFM32PG26B501F3200IM68-B
3. QFN48 / MCU Package includes OPNs EFM32PG26B500F3200IM48-B and EFM32PG26B501F3200IM48-B

6.5 Analog Peripheral Connectivity

Many analog resources are routable and can be connected to numerous GPIO's. The table below indicates which peripherals are available on each GPIO port. When a differential connection is being used Positive inputs are restricted to the EVEN pins and Negative inputs are restricted to the ODD pins. When a single ended connection is being used positive input is available on all pins. See the device Reference Manual for more details on the ABUS and analog peripherals. Note that some functions may not be available on all device variants.

Table 6.5. ABUS Routing Table

Peripheral	Signal	PA		PB		PC		PD	
		EVEN	ODD	EVEN	ODD	EVEN	ODD	EVEN	ODD
ACMP0	ANA_NEG	Yes	Yes	Yes	Yes	Yes	Yes	Yes	Yes
	ANA_POS	Yes	Yes	Yes	Yes	Yes	Yes	Yes	Yes
ACMP1	ANA_NEG	Yes	Yes	Yes	Yes	Yes	Yes	Yes	Yes
	ANA_POS	Yes	Yes	Yes	Yes	Yes	Yes	Yes	Yes
IADC0	ANA_NEG	Yes	Yes	Yes	Yes	Yes	Yes	Yes	Yes
	ANA_POS	Yes	Yes	Yes	Yes	Yes	Yes	Yes	Yes
VDAC0	CH0_ABUS_OUT	Yes	Yes	Yes	Yes	Yes	Yes	Yes	Yes
	CH1_ABUS_OUT	Yes	Yes	Yes	Yes	Yes	Yes	Yes	Yes
VDAC1	CH0_ABUS_OUT	Yes	Yes	Yes	Yes	Yes	Yes	Yes	Yes
	CH1_ABUS_OUT	Yes	Yes	Yes	Yes	Yes	Yes	Yes	Yes

6.6 Digital Peripheral Connectivity

Many digital resources are routable and can be connected to numerous GPIO's. The table below indicates which peripherals are available on each GPIO port. Note that some functions may not be available on all device variants.

Table 6.6. DBUS Routing Table

Peripheral.Resource	PORT			
	PA	PB	PC	PD
ACMP0.DIGOUT	Available	Available	Available	Available
ACMP1.DIGOUT	Available	Available	Available	Available
CMU.CLKIN0			Available	Available
CMU.CLKOUT0			Available	Available
CMU.CLKOUT1			Available	Available
CMU.CLKOUT2	Available	Available		
EUSART0.CS	Available	Available		
EUSART0.CTS	Available	Available		
EUSART0.RTS	Available	Available		
EUSART0.RX	Available	Available		
EUSART0.SCLK	Available	Available		
EUSART0.TX	Available	Available		
EUSART1.CS	Available	Available	Available	Available
EUSART1.CTS	Available	Available	Available	Available
EUSART1.RTS	Available	Available	Available	Available
EUSART1.RX	Available	Available	Available	Available
EUSART1.SCLK	Available	Available	Available	Available
EUSART1.TX	Available	Available	Available	Available
EUSART2.CS	Available	Available	Available	Available
EUSART2.CTS	Available	Available	Available	Available
EUSART2.RTS	Available	Available	Available	Available
EUSART2.RX	Available	Available	Available	Available
EUSART2.SCLK	Available	Available	Available	Available
EUSART2.TX	Available	Available	Available	Available
EUSART3.CS	Available	Available	Available	Available
EUSART3.CTS	Available	Available	Available	Available
EUSART3.RTS	Available	Available	Available	Available
EUSART3.RX	Available	Available	Available	Available
EUSART3.SCLK	Available	Available	Available	Available
EUSART3.TX	Available	Available	Available	Available
FRC.DCLK			Available	Available

Peripheral.Resource	PORT			
	PA	PB	PC	PD
FRC.DFRAME			Available	Available
FRC.DOUT			Available	Available
HFXO0.BUFOUT_REQ_IN_ASYNC	Available	Available		
I2C0.SCL	Available	Available	Available	Available
I2C0.SDA	Available	Available	Available	Available
I2C1.SCL			Available	Available
I2C1.SDA			Available	Available
I2C2.SCL	Available	Available		
I2C2.SDA	Available	Available		
I2C3.SCL			Available	Available
I2C3.SDA			Available	Available
KEYSCAN.COL_OUT_0	Available	Available	Available	Available
KEYSCAN.COL_OUT_1	Available	Available	Available	Available
KEYSCAN.COL_OUT_2	Available	Available	Available	Available
KEYSCAN.COL_OUT_3	Available	Available	Available	Available
KEYSCAN.COL_OUT_4	Available	Available	Available	Available
KEYSCAN.COL_OUT_5	Available	Available	Available	Available
KEYSCAN.COL_OUT_6	Available	Available	Available	Available
KEYSCAN.COL_OUT_7	Available	Available	Available	Available
KEYSCAN.ROW_SENSE_0	Available	Available		
KEYSCAN.ROW_SENSE_1	Available	Available		
KEYSCAN.ROW_SENSE_2	Available	Available		
KEYSCAN.ROW_SENSE_3	Available	Available		
KEYSCAN.ROW_SENSE_4	Available	Available		
KEYSCAN.ROW_SENSE_5	Available	Available		
LETIMER0.OUT0	Available	Available		
LETIMER0.OUT1	Available	Available		
MODEM.ANT0	Available	Available	Available	Available
MODEM.ANT1	Available	Available	Available	Available
MODEM.ANT_ROLL_OVER			Available	Available
MODEM.ANT_RR0			Available	Available
MODEM.ANT_RR1			Available	Available
MODEM.ANT_RR2			Available	Available
MODEM.ANT_RR3			Available	Available
MODEM.ANT_RR4			Available	Available
MODEM.ANT_RR5			Available	Available

Peripheral.Resource	PORT			
	PA	PB	PC	PD
MODEM.ANT_SW_EN			Available	Available
MODEM.ANT_SW_US			Available	Available
MODEM.ANT_TRIG			Available	Available
MODEM.ANT_TRIG_STOP			Available	Available
MODEM.DCLK	Available	Available		
MODEM.DIN	Available	Available		
MODEM.DOUT	Available	Available		
PCNT0.S0IN	Available	Available		
PCNT0.S1IN	Available	Available		
PRS.ASYNCH0	Available	Available		
PRS.ASYNCH1	Available	Available		
PRS.ASYNCH2	Available	Available		
PRS.ASYNCH3	Available	Available		
PRS.ASYNCH4	Available	Available		
PRS.ASYNCH5	Available	Available		
PRS.ASYNCH6			Available	Available
PRS.ASYNCH7			Available	Available
PRS.ASYNCH8			Available	Available
PRS.ASYNCH9			Available	Available
PRS.ASYNCH10			Available	Available
PRS.ASYNCH11			Available	Available
PRS.ASYNCH12	Available	Available		
PRS.ASYNCH13	Available	Available		
PRS.ASYNCH14	Available	Available		
PRS.ASYNCH15	Available	Available		
PRS.SYNCH0	Available	Available	Available	Available
PRS.SYNCH1	Available	Available	Available	Available
PRS.SYNCH2	Available	Available	Available	Available
PRS.SYNCH3	Available	Available	Available	Available
RAC.LNAEN	Available	Available	Available	Available
RAC.PAEN	Available	Available	Available	Available
TIMER0.CC0	Available	Available	Available	Available
TIMER0.CC1	Available	Available	Available	Available
TIMER0.CC2	Available	Available	Available	Available
TIMER0.CDTI0	Available	Available	Available	Available
TIMER0.CDTI1	Available	Available	Available	Available

Peripheral.Resource	PORT			
	PA	PB	PC	PD
TIMER0.CDTI2	Available	Available	Available	Available
TIMER1.CC0	Available	Available	Available	Available
TIMER1.CC1	Available	Available	Available	Available
TIMER1.CC2	Available	Available	Available	Available
TIMER1.CDTI0	Available	Available	Available	Available
TIMER1.CDTI1	Available	Available	Available	Available
TIMER1.CDTI2	Available	Available	Available	Available
TIMER2.CC0	Available	Available		
TIMER2.CC1	Available	Available		
TIMER2.CC2	Available	Available		
TIMER2.CDTI0	Available	Available		
TIMER2.CDTI1	Available	Available		
TIMER2.CDTI2	Available	Available		
TIMER3.CC0			Available	Available
TIMER3.CC1			Available	Available
TIMER3.CC2			Available	Available
TIMER3.CDTI0			Available	Available
TIMER3.CDTI1			Available	Available
TIMER3.CDTI2			Available	Available
TIMER4.CC0	Available	Available		
TIMER4.CC1	Available	Available		
TIMER4.CC2	Available	Available		
TIMER4.CDTI0	Available	Available		
TIMER4.CDTI1	Available	Available		
TIMER4.CDTI2	Available	Available		
TIMER5.CC0	Available	Available	Available	Available
TIMER5.CC1	Available	Available	Available	Available
TIMER5.CC2	Available	Available	Available	Available
TIMER5.CDTI0	Available	Available	Available	Available
TIMER5.CDTI1	Available	Available	Available	Available
TIMER5.CDTI2	Available	Available	Available	Available
TIMER6.CC0	Available	Available	Available	Available
TIMER6.CC1	Available	Available	Available	Available
TIMER6.CC2	Available	Available	Available	Available
TIMER6.CDTI0	Available	Available	Available	Available
TIMER6.CDTI1	Available	Available	Available	Available

Peripheral.Resource	PORT			
	PA	PB	PC	PD
TIMER6.CDTI2	Available	Available	Available	Available
TIMER7.CC0	Available	Available	Available	Available
TIMER7.CC1	Available	Available	Available	Available
TIMER7.CC2	Available	Available	Available	Available
TIMER7.CDTI0	Available	Available	Available	Available
TIMER7.CDTI1	Available	Available	Available	Available
TIMER7.CDTI2	Available	Available	Available	Available
TIMER8.CC0	Available	Available	Available	Available
TIMER8.CC1	Available	Available	Available	Available
TIMER8.CC2	Available	Available	Available	Available
TIMER8.CDTI0	Available	Available	Available	Available
TIMER8.CDTI1	Available	Available	Available	Available
TIMER8.CDTI2	Available	Available	Available	Available
TIMER9.CC0	Available	Available	Available	Available
TIMER9.CC1	Available	Available	Available	Available
TIMER9.CC2	Available	Available	Available	Available
TIMER9.CDTI0	Available	Available	Available	Available
TIMER9.CDTI1	Available	Available	Available	Available
TIMER9.CDTI2	Available	Available	Available	Available
USART0.CLK	Available	Available	Available	Available
USART0.CS	Available	Available	Available	Available
USART0.CTS	Available	Available	Available	Available
USART0.RTS	Available	Available	Available	Available
USART0.RX	Available	Available	Available	Available
USART0.TX	Available	Available	Available	Available
USART1.CLK	Available	Available	Available	Available
USART1.CS	Available	Available	Available	Available
USART1.CTS	Available	Available	Available	Available
USART1.RTS	Available	Available	Available	Available
USART1.RX	Available	Available	Available	Available
USART1.TX	Available	Available	Available	Available
USART2.CLK	Available	Available	Available	Available
USART2.CS	Available	Available	Available	Available
USART2.CTS	Available	Available	Available	Available
USART2.RTS	Available	Available	Available	Available
USART2.RX	Available	Available	Available	Available

Peripheral.Resource	PORT			
	PA	PB	PC	PD
USART2.TX	Available	Available	Available	Available

7. QFN48 Package Specifications

7.1 QFN48 Package Dimensions

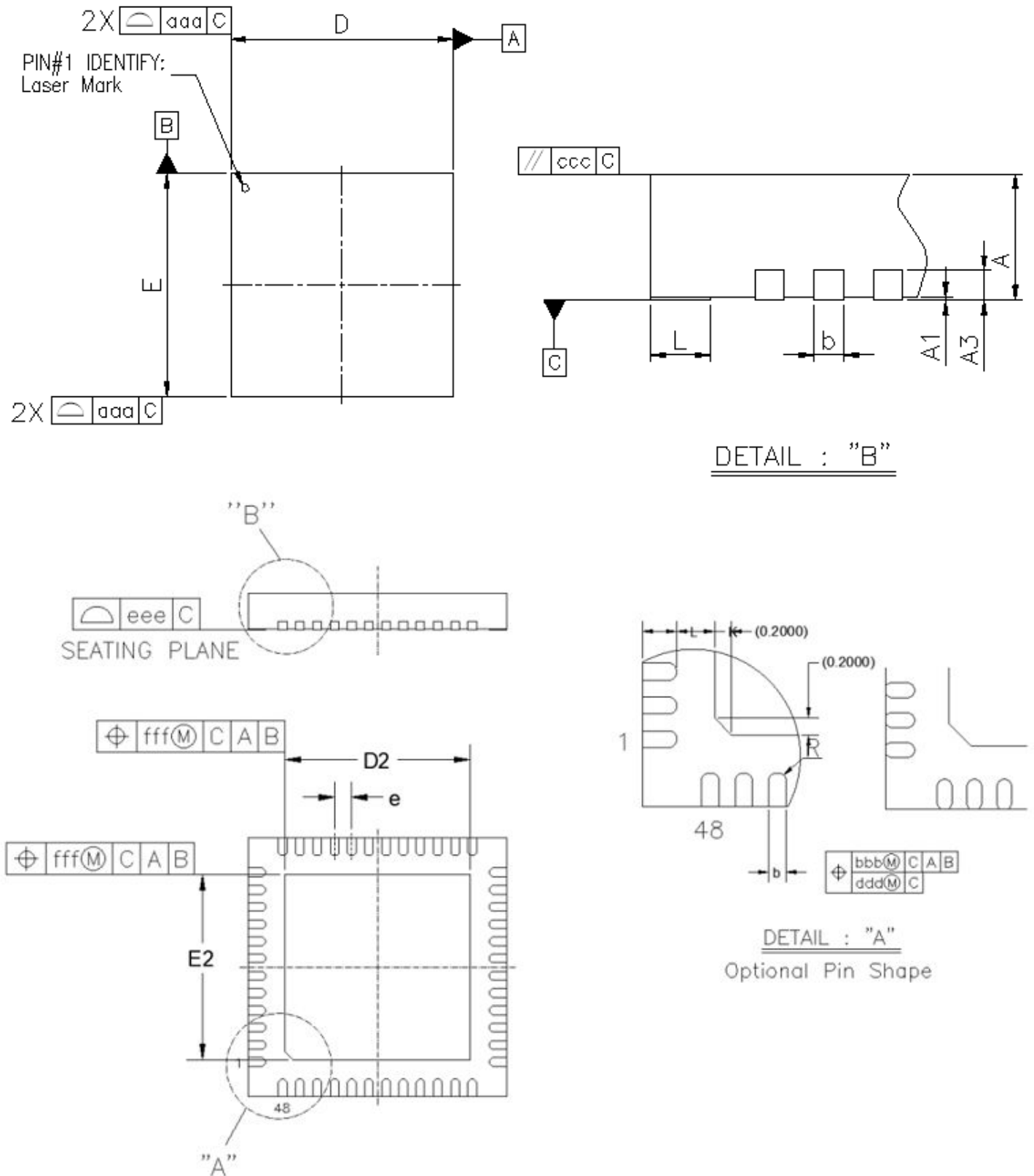

Figure 7.1. QFN48 Package Drawing

Table 7.1. QFN48 Package Dimensions

Dimension	Min	Typ	Max
A	0.80	0.85	0.90
A1	0.00	0.02	0.05
A3	0.20 REF		
b	0.15	0.2	0.25
D	5.90	6.00	6.10
E	5.90	6.00	6.10
e	0.40 BSC		
D2	4.15	4.30	4.45
E2	4.15	4.30	4.45
L	0.30	0.4	0.50
K	0.20	—	—
R	0.075	—	—
aaa	0.10		
bbb	0.07		
ccc	0.10		
ddd	0.05		
eee	0.08		
fff	0.10		

Note:

1. All dimensions shown are in millimeters (mm) unless otherwise noted.
2. Dimensioning and Tolerancing per ANSI Y14.5M-1994.
3. This drawing conforms to the JEDEC Outline MS-013, Variation AA.
4. Recommended reflow profile per JEDEC J-STD-020C specification for small body, lead-free components.

7.2 QFN48 PCB Land Pattern

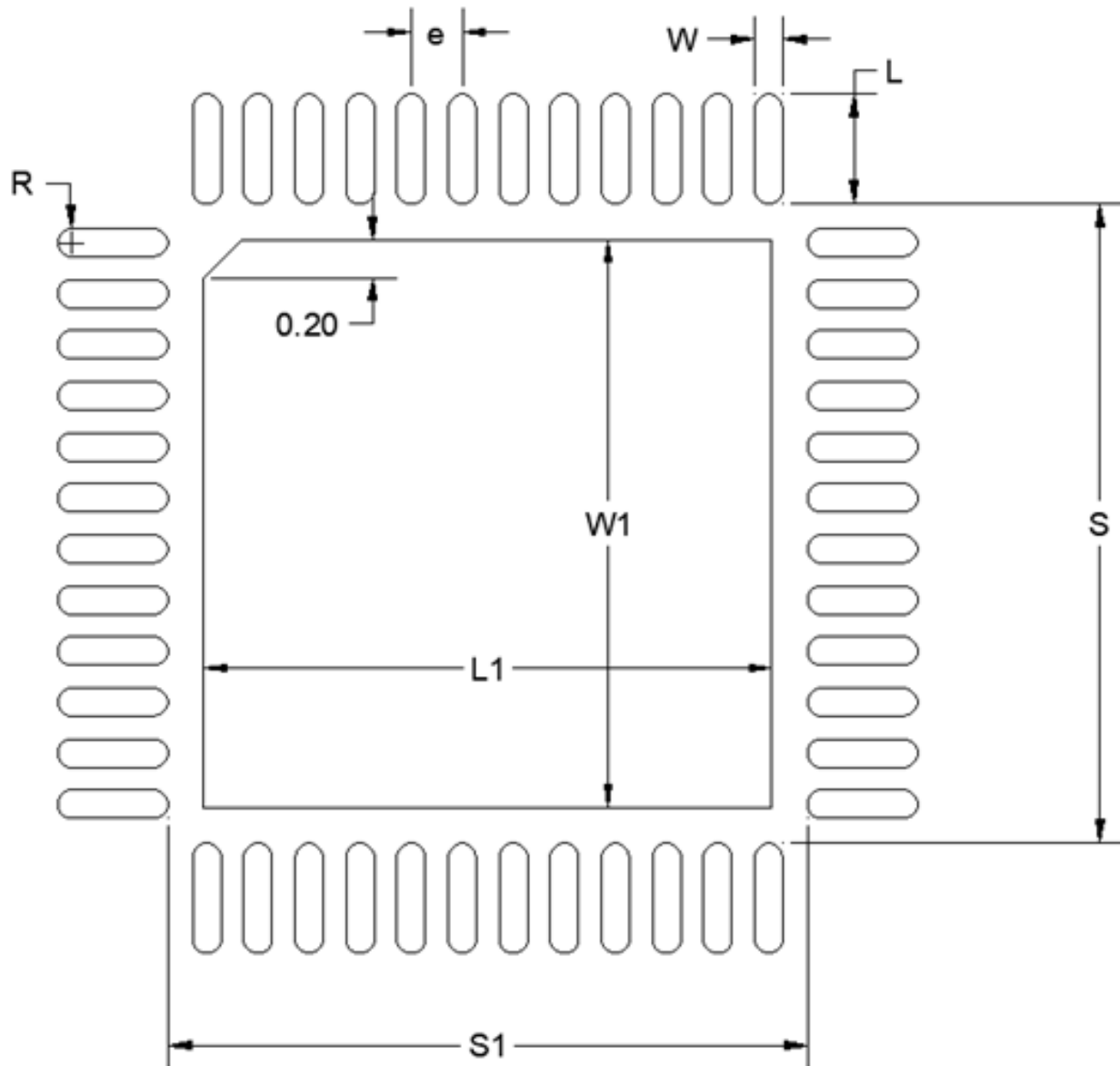

Figure 7.2. QFN48 PCB Land Pattern Drawing

Table 7.2. QFN48 PCB Land Pattern Dimensions

Dimension	Typ
L	0.86
W	0.22
e	0.40
S	5.01
S1	5.01
L1	4.45
W1	4.45
R	0.11

Dimension	Typ
<p>Note:</p> <ol style="list-style-type: none"> 1. All dimensions shown are in millimeters (mm) unless otherwise noted. 2. This Land Pattern Design is based on the IPC-7351 guidelines. 3. All metal pads are to be non-solder mask defined (NSMD). Clearance between the solder mask and the metal pad is to be 60 μm minimum, all the way around the pad. 4. A stainless steel, laser-cut and electro-polished stencil with trapezoidal walls should be used to assure good solder paste release. 5. The stencil thickness should be 0.101 mm (4 mils). 6. The ratio of stencil aperture to land pad size can be 1:1 for all perimeter pads. 7. A 3x3 array of 1.10mm x 1.10mm openings on 1.30mm pitch should be used for the center ground pad. 8. A No-Clean, Type-3 solder paste is recommended. 9. The recommended card reflow profile is per the JEDEC/IPC J-STD-020 specification for Small Body Components. 10. Above notes and stencil design are shared as recommendations only. A customer or user may find it necessary to use different parameters and fine tune their SMT process as required for their application and tooling. 	

7.3 QFN48 Package Marking

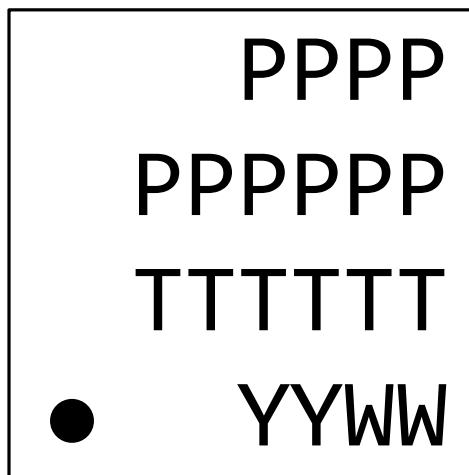

Figure 7.3. QFN48 Package Marking

The package marking consists of:

- Line 1: P P P P – The product family codes (PG26)
- Line 2: P P P P P – The product option codes:
 - 1) Security (A = Secure Vault Mid | B = Secure Vault High)
 - 2-4) Product Feature Codes
 - 5) Flash (R = 3200k | K = 2048k | J = 1024k)
 - 6) Temperature grade (G = -40 to 85 °C | I = -40 to 125 °C)
- T T T T T – A trace or manufacturing code. The first letter is the device revision.
- Y Y – The last 2 digits of the assembly year.
- W W – The 2-digit workweek when the device was assembled.

8. QFN68 Package Specifications

8.1 QFN68 Package Dimensions

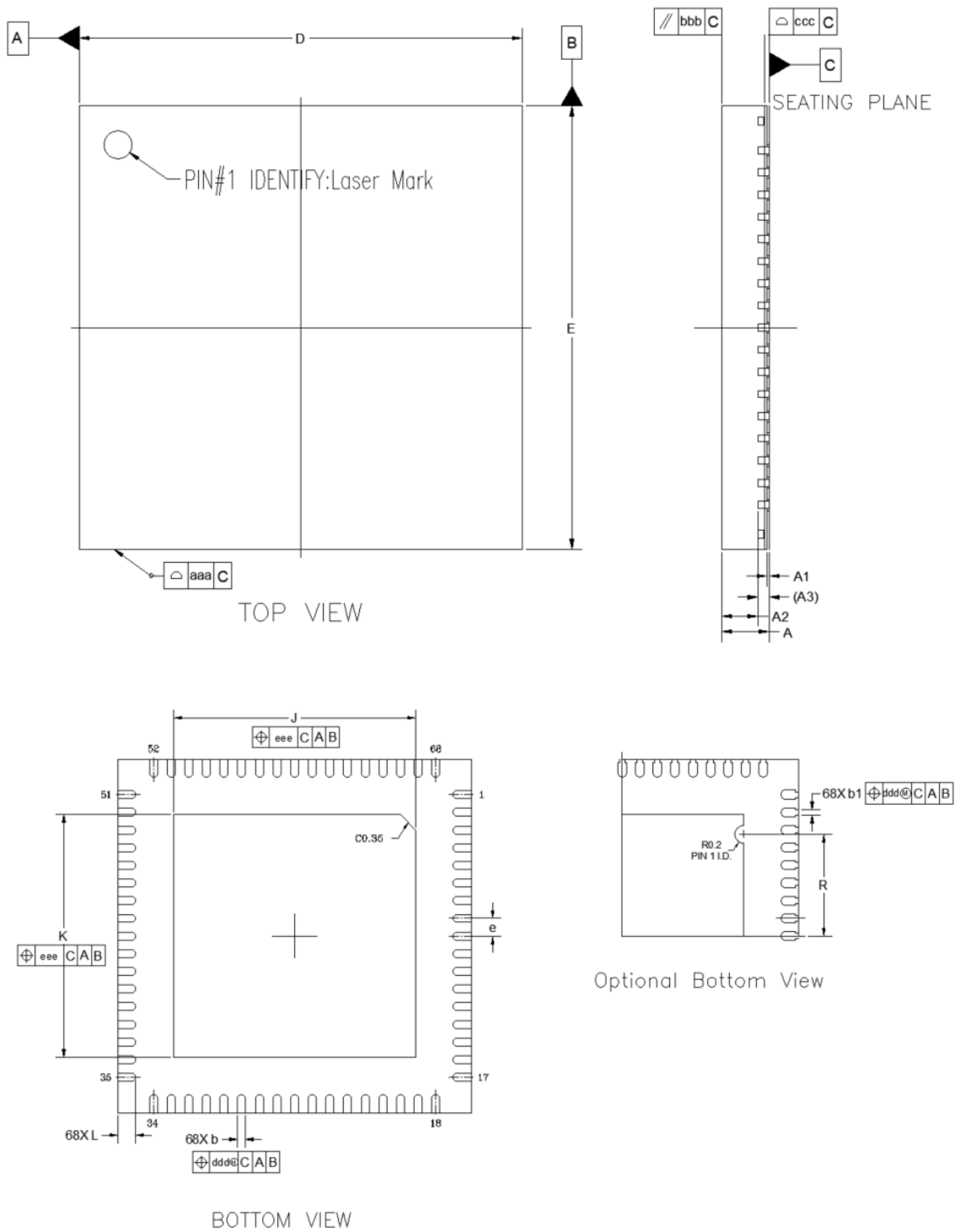

Figure 8.1. QFN68 Package Drawing

Table 8.1. QFN68 Package Dimensions

Dimension	Min	Typ	Max
A	0.80	0.85	0.90
A1	0.00	0.035	0.05
A2	—	0.65	—
A3	0.203 REF		
b	0.13	0.19	0.25
b1	0.075	0.125	0.175
D	8.00 BSC		
E	8.00 BSC		
e	0.40 BSC		
J	5.40	5.50	5.60
K	5.40	5.50	5.60
L	0.30	0.40	0.50
R	2.20	2.30	2.40
aaa	—	0.10	—
bbb	—	0.10	—
ccc	—	0.08	—
ddd	—	0.10	—
eee	—	0.10	—

Note:

1. All dimensions shown are in millimeters (mm) unless otherwise noted.
2. Dimensioning and Tolerancing per ANSI Y14.5M-1994.

8.2 QFN68 PCB Land Pattern

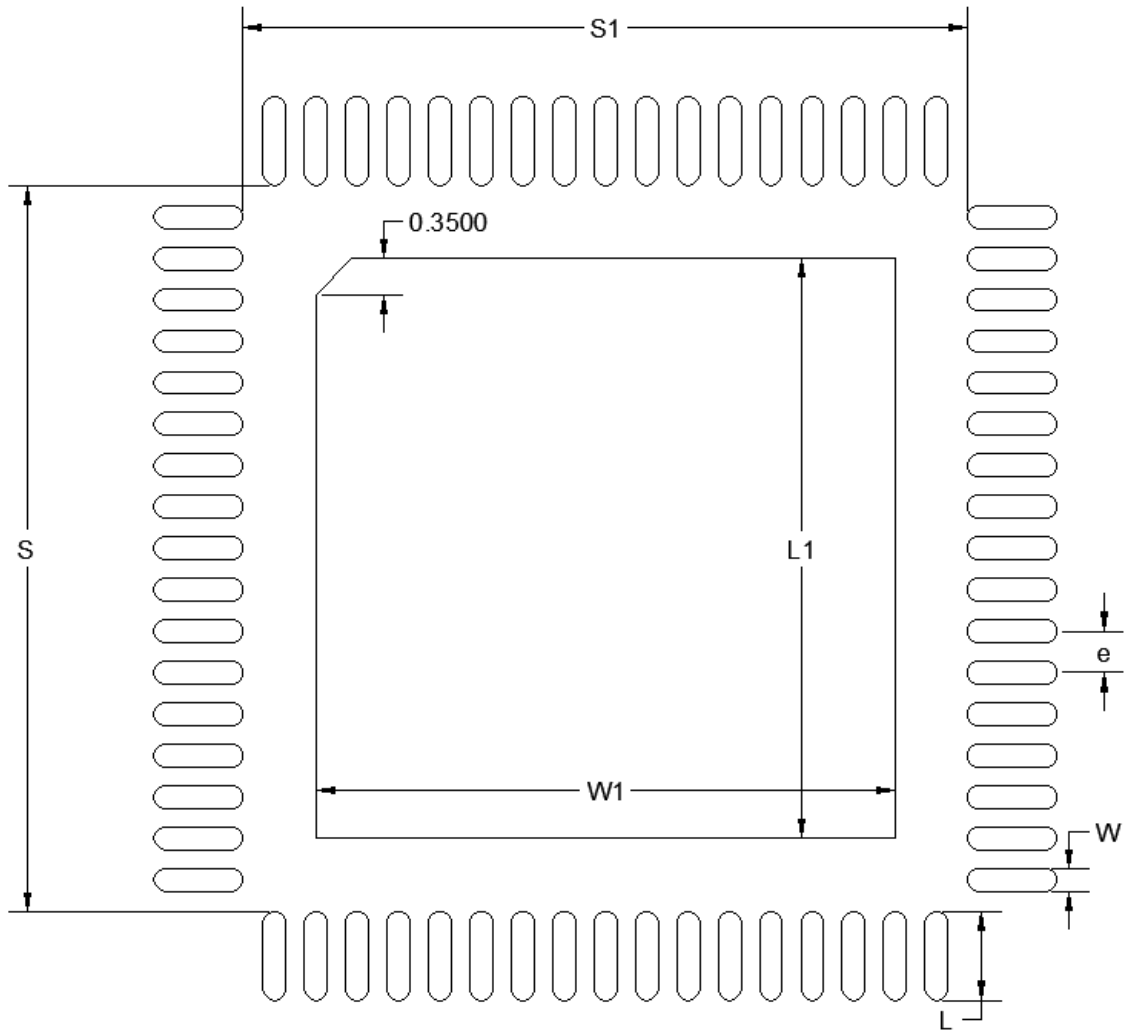

Figure 8.2. QFN68 PCB Land Pattern Drawing

Table 8.2. QFN68 PCB Land Pattern Dimensions

Dimension	Typ
S	7.05
S1	7.05
e	0.40
W	0.20
L	0.85
W1	5.60
L1	5.60

Note:

1. All dimensions shown are in millimeters (mm) unless otherwise noted.
2. Dimensioning and Tolerancing is per the ANSI Y14.5M-1994 specification.
3. This Land Pattern Design is based on IPC-SM-782 guidelines.
4. All dimensions shown are at Maximum Material Condition (MMC). Least Material Condition (LMC) is calculated based on a Fabrication Allowance of 0.05mm.
5. All pads are to be non-solder mask defined (NSMD). Clearance between the solder mask and the metal pad is to be 60 µm minimum, all the way around the pad.
6. A stainless steel, laser-cut and electro-polished stencil with trapezoidal walls should be used to assure good solder paste release.
7. The stencil thickness should be 0.102 mm (4 mils).
8. The ratio of stencil aperture to land pad size should be 1:1 for the perimeter pads.
9. A 3x3 array of 1.31 mm square openings on a 1.80 mm pitch should be used for the center ground pad.
10. A No-Clean, Type-3 solder paste is recommended.
11. The recommended card reflow profile is per the JEDEC/IPC J-STD-020C specification for Small Body Components.
12. **Above notes and stencil design are shared as recommendations only. A customer or user may find it necessary to use different parameters and fine tune their SMT process as required for their application and tooling.**

8.3 QFN68 Package Marking

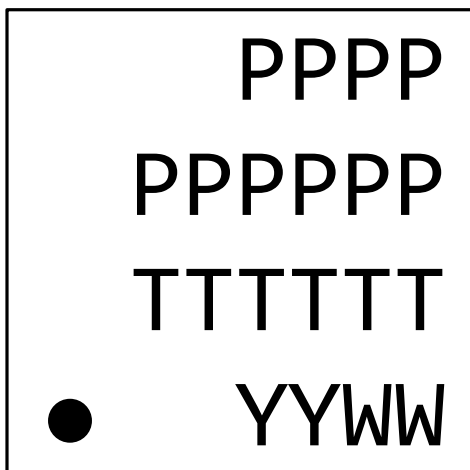

Figure 8.3. QFN68 Package Marking

The package marking consists of:

- Line 1: P P P P – The product family codes (PG26)
- Line 2: P P P P P P – The product option codes:
 - 1) Security (A = Secure Vault Mid | B = Secure Vault High)
 - 2-4) Product Feature Codes
 - 5) Flash (R = 3200k | K = 2048k | J = 1024k)
 - 6) Temperature grade (G = -40 to 85 °C | I = -40 to 125 °C)
- T T T T T T – A trace or manufacturing code. The first letter is the device revision.
- Y Y – The last 2 digits of the assembly year.
- W W – The 2-digit workweek when the device was assembled.

9. BGA136 Package Specifications

9.1 BGA136 Package Dimensions

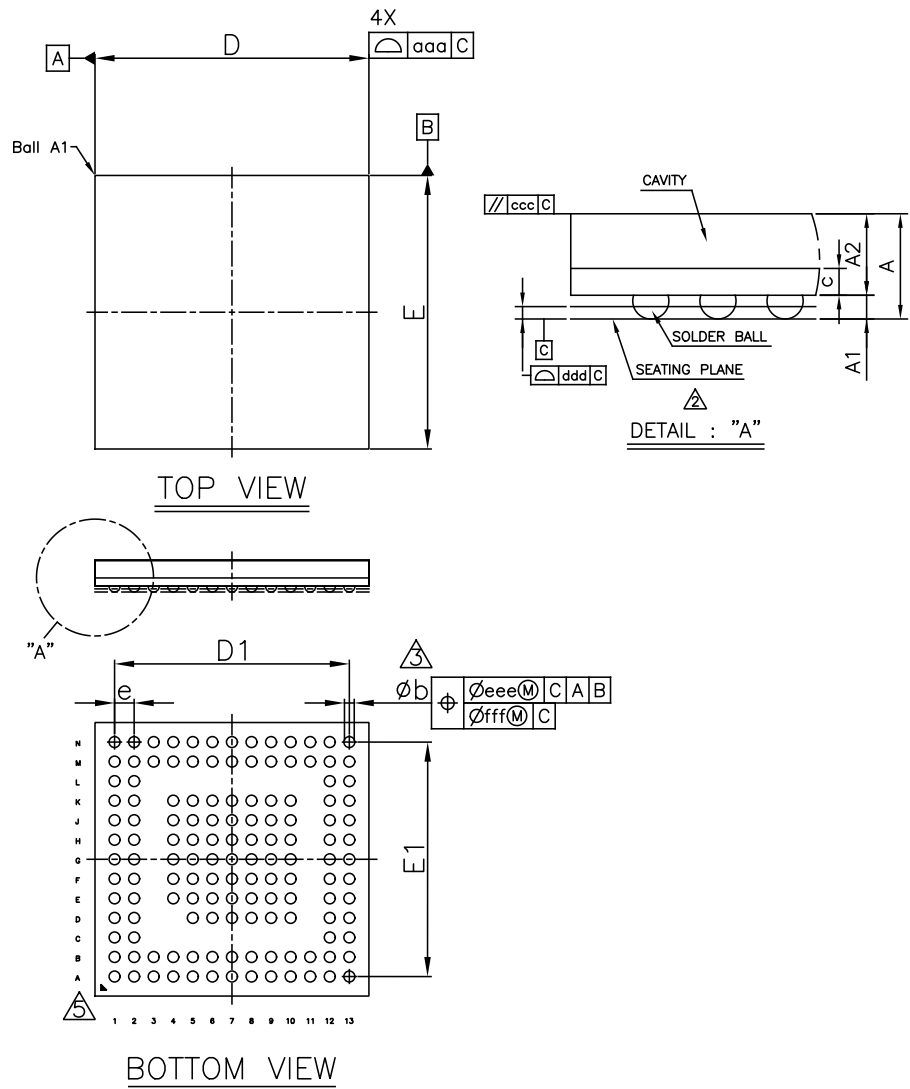

Figure 9.1. BGA136 Package Drawing

Table 9.1. BGA136 Package Dimensions

Dimension	Min (mm)	Typ (mm)	Max (mm)
A	0.749	0.820	0.891
A1	0.110	0.160	0.210
A2	0.610	0.660	0.710
c	0.170	0.210	0.250
D	6.900	7.000	7.100
E	6.900	7.000	7.100
D1	—	6.000	—
E1	—	6.000	—

Dimension	Min (mm)	Typ (mm)	Max (mm)
e	—	0.500	—
b	0.220	0.270	0.320
aaa	0.150		
ccc	0.100		
ddd	0.080		
eee	0.150		
fff	0.050		

Note:

1. All dimensions shown are in millimeters (mm) unless otherwise noted.
2. Primary datum C and seating plane are defined by the spherical crowns of the solder balls.
3. Dimension b is measured at the maximum solder ball diameter, parallel to primary datum C.
4. Special characteristics C class: ccc, ddd
5. The pattern of pin 1 fiducial is for reference only.
6. Ball placement uses 0.250 mm solder ball. BGA pad solder mask opening = 0.250 mm.
7. Dimensioning and Tolerancing per ANSI Y14.5M-1994.

9.2 BGA136 PCB Land Pattern

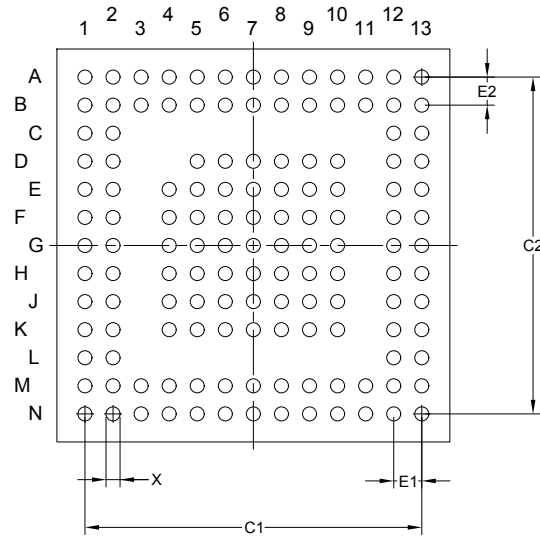

Figure 9.2. BGA136 PCB Land Pattern Drawing

Table 9.2. BGA136 PCB Land Pattern Dimensions

Dimension	NOM (mm)
X	0.20
C1	6.00
C2	6.00
E1	0.50
E2	0.50

Note:

1. All dimensions shown are in millimeters (mm) unless otherwise noted.
2. Dimensioning and Tolerancing is per the ANSI Y14.5M-1994 specification.
3. This Land Pattern Design is based on the IPC-7351 guidelines.
4. All metal pads are to be non-solder mask defined (NSMD). Clearance between the solder mask and the metal pad is to be 60um minimum, all the way around the pad.
5. A stainless steel, laser-cut and electro-polished stencil with trapezoidal walls should be used to assure good solder paste release.
6. The stencil thickness should be 0.125 mm (5 mils).
7. The ratio of stencil aperture to land pad size should be 1:1.
8. A No-Clean, Type-3 solder paste is recommended.
9. The recommended card reflow profile is per the JEDEC/IPC J-STD-020 specification for Small Body Components.
10. **Above notes and stencil design are shared as recommendations only. A customer or user may find it necessary to use different parameters and fine tune their SMT process as required for their application and tooling.**

9.3 BGA136 Package Marking

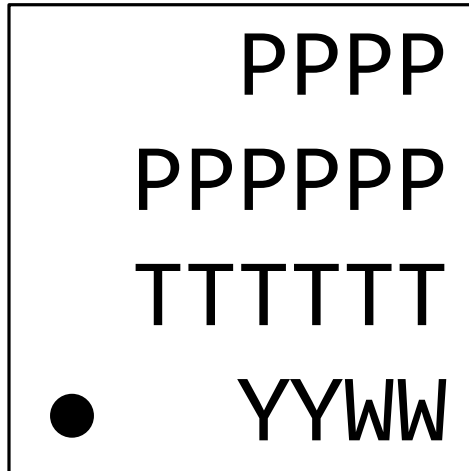

Figure 9.3. BGA136 Package Marking

The package marking consists of:

- Line 1: P P P P – The product family codes (PG26)
- Line 2: P P P P P – The product option codes:
 - 1) Security (A = Secure Vault Mid | B = Secure Vault High)
 - 2-4) Product Feature Codes
 - 5) Flash (R = 3200k | K = 2048k | J = 1024k)
 - 6) Temperature grade (G = -40 to 85 °C | I = -40 to 125 °C)
- T T T T T – A trace or manufacturing code. The first letter is the device revision.
- Y Y – The last 2 digits of the assembly year.
- W W – The 2-digit workweek when the device was assembled.

10. Revision History

Revision 1.1

January, 2025

- Updated Memory Map to remove Radio-specific RAM
- Added QFN48 Package Specifications
- Updated System Overview section to remove radio-specific text
- Updated Electrical Specifications tables:
 - Removed "EM3, 32 kB RAM retention" spec row from 3V Current Consumption Table
 - Removed "Radio RAM" from all current consumption specs
 - Removed "PAVDD", "RFVDD" and "Radio HCLK frequency" from General Operating Conditions table
 - Removed "RF2G4_IO" pin from Absolute Maximum Ratings table
 - Added omitted Crystal Frequency spec line to HFXO table
 - Updated DC-DC Converter table to remove radio-specific rows and correct PFMX mode max output current

Revision 1.0

December, 2024

- Updated Electrical Specifications tables.
- Updated Typical Performance plots.

Revision 0.5

November, 2024

- Updated Ordering Info table.
- Updated Electrical Specifications tables.
- Updated Typical Performance plots.

Revision 0.1

August, 2024

- Initial release.

Simplicity Studio

One-click access to MCU and wireless tools, documentation, software, source code libraries & more. Available for Windows, Mac and Linux!



IoT Portfolio
www.silabs.com/IoT



SW/HW
www.silabs.com/simplicity



Quality
www.silabs.com/quality



Support & Community
www.silabs.com/community

Disclaimer

Silicon Labs intends to provide customers with the latest, accurate, and in-depth documentation of all peripherals and modules available for system and software implementers using or intending to use the Silicon Labs products. Characterization data, available modules and peripherals, memory sizes and memory addresses refer to each specific device, and "Typical" parameters provided can and do vary in different applications. Application examples described herein are for illustrative purposes only. Silicon Labs reserves the right to make changes without further notice to the product information, specifications, and descriptions herein, and does not give warranties as to the accuracy or completeness of the included information. Without prior notification, Silicon Labs may update product firmware during the manufacturing process for security or reliability reasons. Such changes will not alter the specifications or the performance of the product. Silicon Labs shall have no liability for the consequences of use of the information supplied in this document. This document does not imply or expressly grant any license to design or fabricate any integrated circuits. The products are not designed or authorized to be used within any FDA Class III devices, applications for which FDA premarket approval is required or Life Support Systems without the specific written consent of Silicon Labs. A "Life Support System" is any product or system intended to support or sustain life and/or health, which, if it fails, can be reasonably expected to result in significant personal injury or death. Silicon Labs products are not designed or authorized for military applications. Silicon Labs products shall under no circumstances be used in weapons of mass destruction including (but not limited to) nuclear, biological or chemical weapons, or missiles capable of delivering such weapons. Silicon Labs disclaims all express and implied warranties and shall not be responsible or liable for any injuries or damages related to use of a Silicon Labs product in such unauthorized applications.

Trademark Information

Silicon Laboratories Inc.[®], Silicon Laboratories[®], Silicon Labs[®], SiLabs[®] and the Silicon Labs logo[®], Bluegiga[®], Bluegiga Logo[®], EFM[®], EFM32[®], EFR, Ember[®], Energy Micro, Energy Micro logo and combinations thereof, "the world's most energy friendly microcontrollers", Redpine Signals[®], WiSeConnect, n-Link, EZLink[®], EZRadio[®], EZRadioPRO[®], Gecko[®], Gecko OS, Gecko OS Studio, Precision32[®], Simplicity Studio[®], Telegesis, the Telegesis Logo[®], USBXpress[®], Zentri, the Zentri logo and Zentri DMS, Z-Wave[®], and others are trademarks or registered trademarks of Silicon Labs. ARM, CORTEX, Cortex-M3 and THUMB are trademarks or registered trademarks of ARM Holdings. Keil is a registered trademark of ARM Limited. Wi-Fi is a registered trademark of the Wi-Fi Alliance. All other products or brand names mentioned herein are trademarks of their respective holders.



Silicon Laboratories Inc.
400 West Cesar Chavez
Austin, TX 78701
USA

www.silabs.com