



Thunderboard EFR32BG22

EFR32BG22C224F512IM40

Board Function	Page
Title Page	1
EFR32BG22	2
Sensors and Peripherals	3
Power and Mini Simplicity	4
On-board Debugger	5

LEGAL NOTICE:
SILICON LABORATORIES INC. ("SILICON LABS") AND/OR ITS LICENSORS DO NOT WARRANT THE ACCURACY OR COMPLETENESS OF THIS SCHEMATIC OR ANY INFORMATION CONTAINED WITHIN THIS SCHEMATIC. IT IS PROVIDED "AS-IS" FOR REFERENCE ONLY. SILICON LABS DOES NOT WARRANT THAT THIS DESIGN WILL MEET THE SPECIFICATIONS, BE SUITABLE FOR YOUR APPLICATION OR FIT FOR ANY PARTICULAR PURPOSE, OR WILL OPERATE IN YOUR IMPLEMENTATION. SILICON LABS AND ITS LICENSORS DO NOT WARRANT THAT THE DESIGN IMPLIED IN THIS SCHEMATIC IS PRODUCTION-WORTHY. YOU SHOULD COMPLETELY VALIDATE AND TEST YOUR DESIGN IMPLEMENTATION TO CONFIRM SYSTEM FUNCTIONALITY FOR YOUR APPLICATION.



Revision History	
Rev.	Description
A02	The design is based on BRD4184A. There is a new pinout of the EFR32BG22, and the ambient light sensor has been changed.

<p>SILICON LABS</p>	Schematic Title		
	Thunderboard EFR32BG22		
Designed: ESH		Approved: JSH	
Size: A3	BOM Doc No:	Document number	Revision
Design Created Date: Wednesday, July 31, 2019		Document number: BRD4184B	Revision: A02
Sheet Created Date: Wednesday, July 31, 2019	Sheet Modified Date: Monday, June 08, 2020	Sheet	1 of 5

EFR32BG22 Power Section

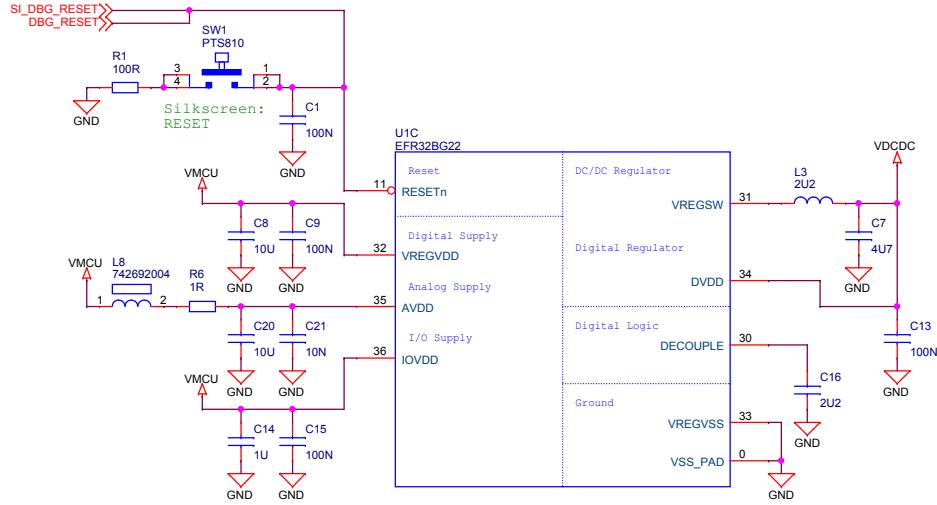

EFR32BG22 RF Section

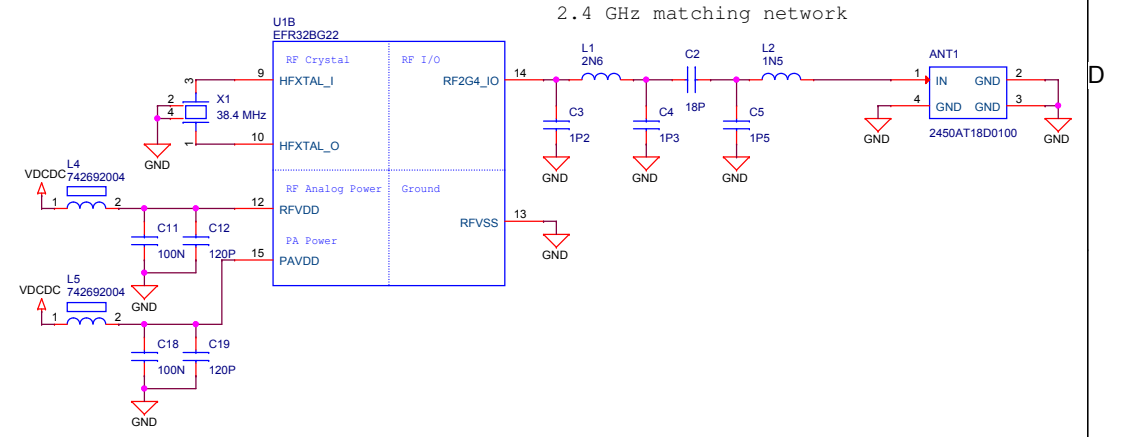

EFR32BG22 IOs & Signal Assignments

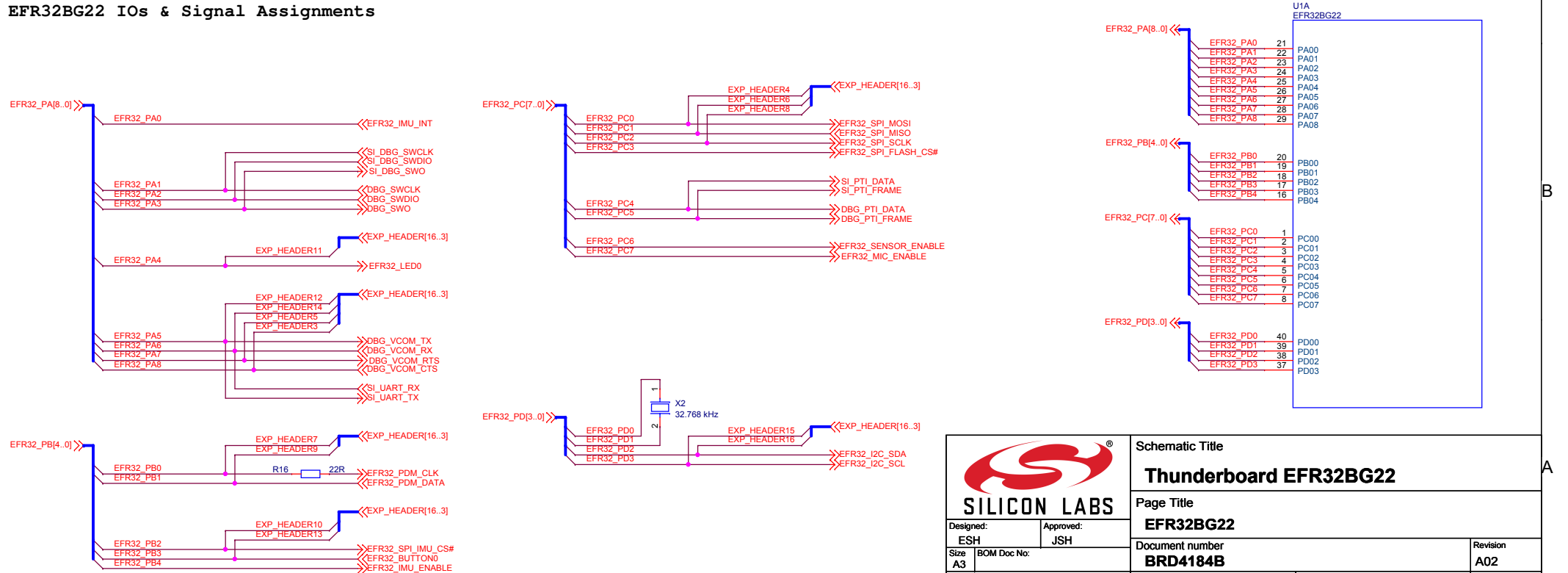

		Schematic Title	
		Thunderboard EFR32BG22	
Design: ESH Size: A3 Design Created Date: Wednesday, July 31, 2019		Page Title	
		EFR32BG22	
Approved: JSH BOM Doc No: Sheet Created Date: Thursday, July 31, 2019		Document number	
		BRD4184B	
Sheet Modified Date: Thursday, June 18, 2020		Revision	
Sheet 2 of 5		A02	

Sensor Power/Isolation

There are no pull-down resistors on the enable pins, and software should therefore immediately drive the lines to prevent the pins from floating.

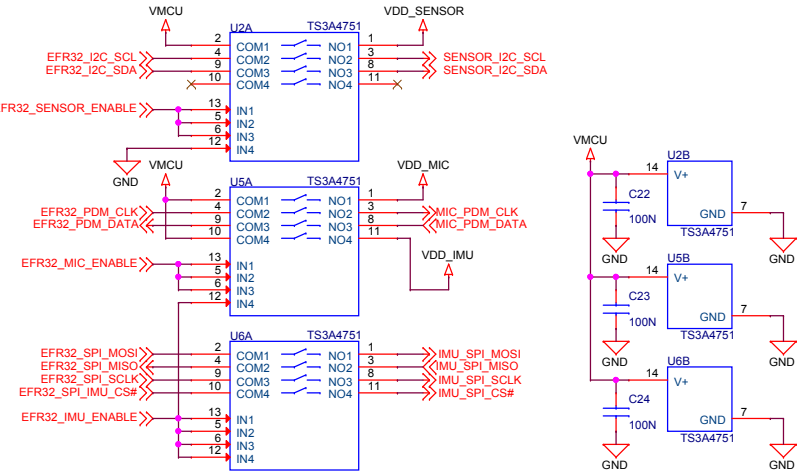

SPI Flash

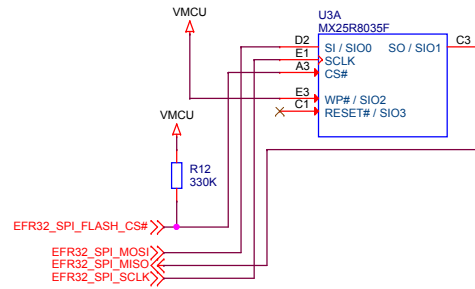

The SPI bus is shared with the IMU.

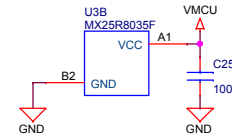

6-axis Inertial Sensor (IMU)

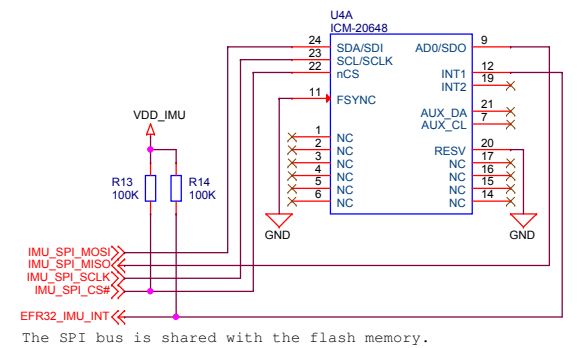

The SPI bus is shared with the flash memory.

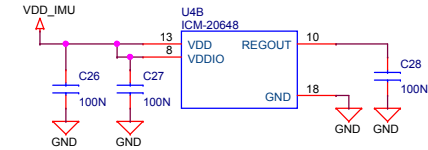

PDM Microphones

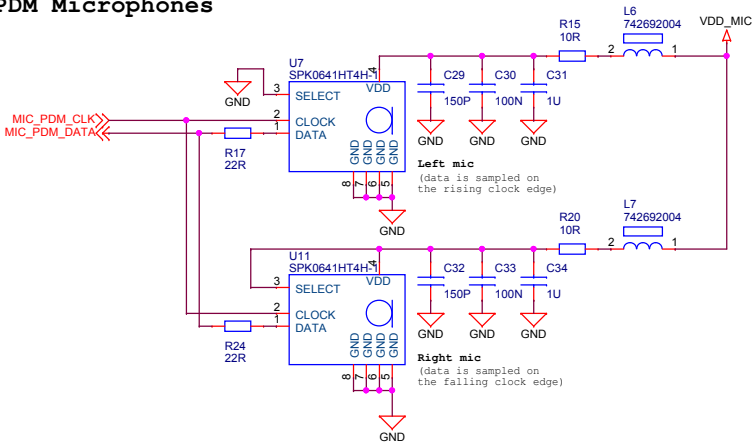

UV/Ambient Light Sensor

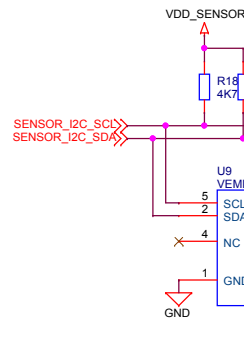

Hall-effect Sensor

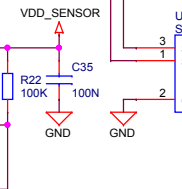

RH/Temp Sensor

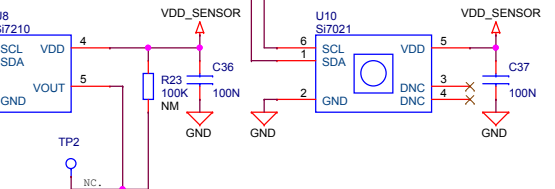

Push Buttons & LEDs

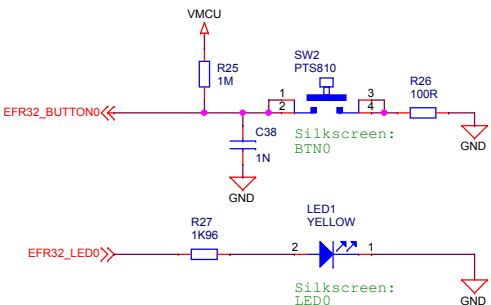

Breakout Pads - EXP Header

All signals routed to the EXP header are used on the board as well. Take care to avoid signal conflicts (see page 2 for signal assignments).

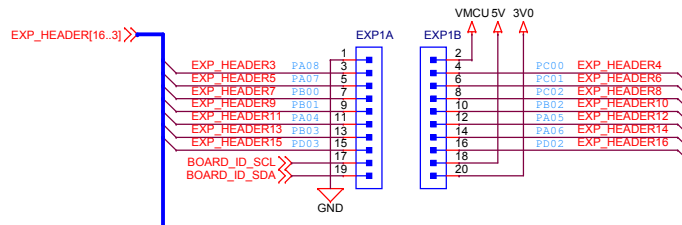

Schematic Title

Thunderboard EFR32BG22

Page Title

Sensors and Peripherals

Designed: ESH

Approved: JSH

Size: A3

BOM Doc No:

Document number

BRD4184B

Design Created Date: Wednesday, July 31, 2019

Sheet Created Date: Friday, August 02, 2019

Sheet Modified Date: Monday, June 08, 2020

Revision

A02

Sheet 3 of 5

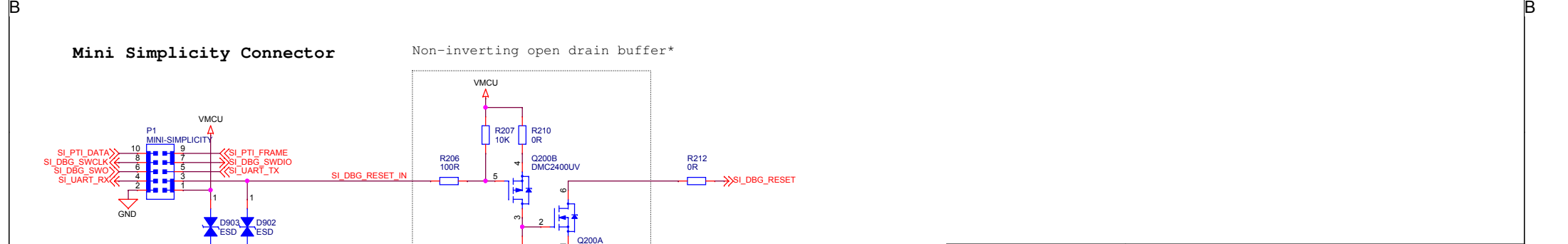
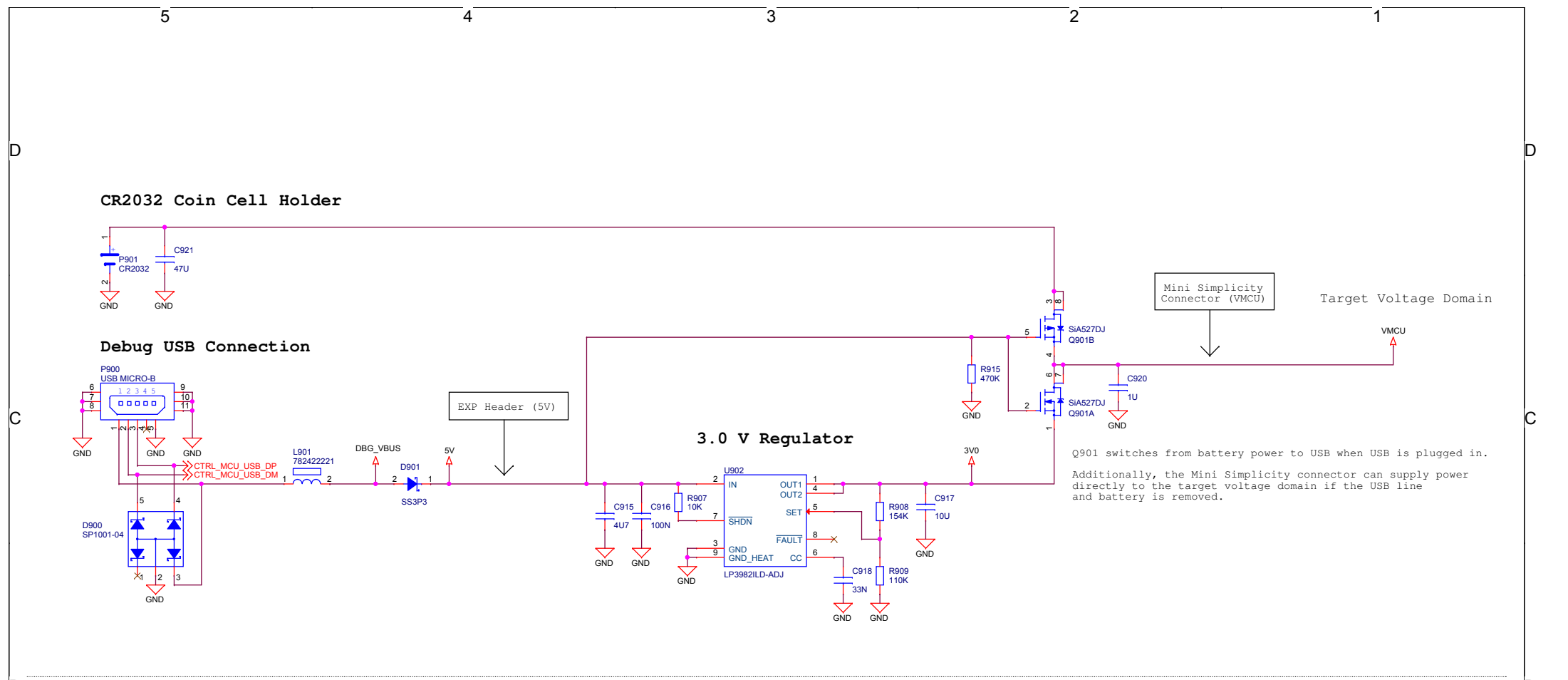

		Schematic Title	
		Thunderboard EFR32BG22	
Designed: ESH Size: A3		Page Title	
		Power and Mini Simplicity	
Approved: JSH BOM Doc No:		Document number	
		BRD4184B	
Design Created Date: Wednesday, July 31, 2019		Sheet Created Date Monday, August 12, 2019	Sheet Modified Date Monday, June 08, 2020
		Revision	Sheet
		A02	4 of 5

On-board Debugger

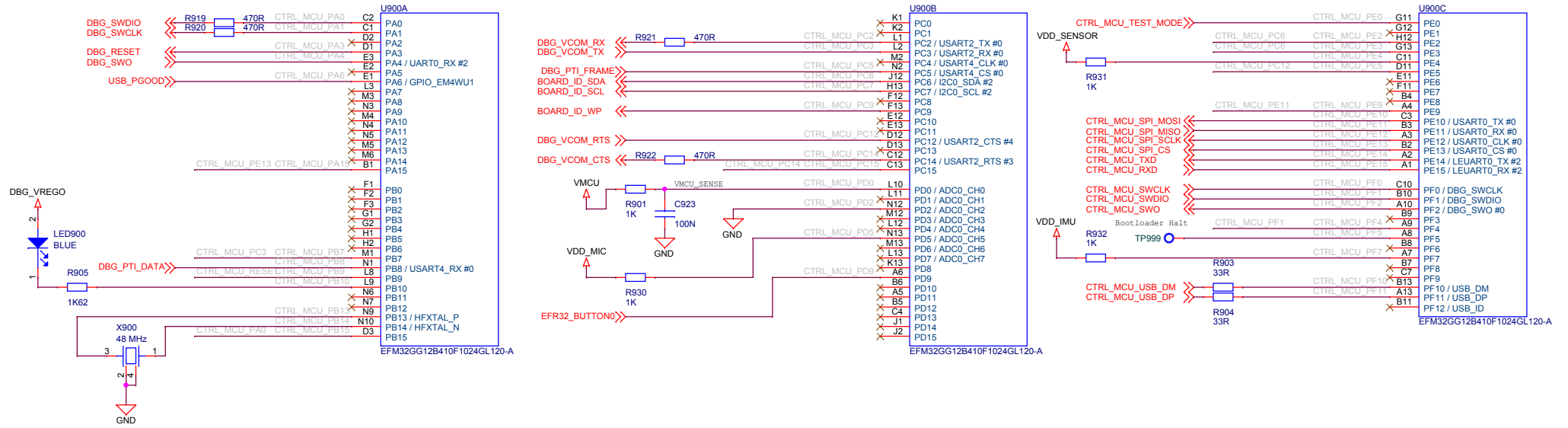

USB Cable Detection and Power Isolation

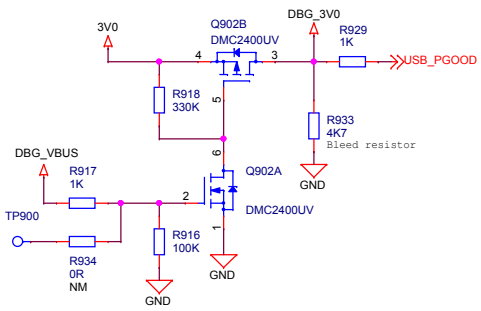

Serial Flash

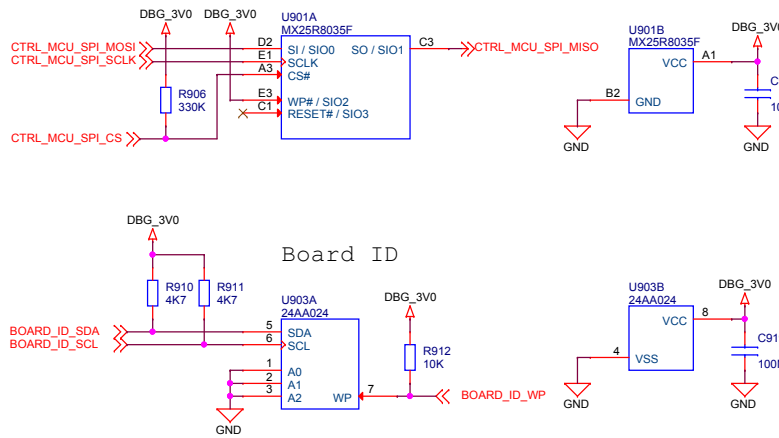

Board ID

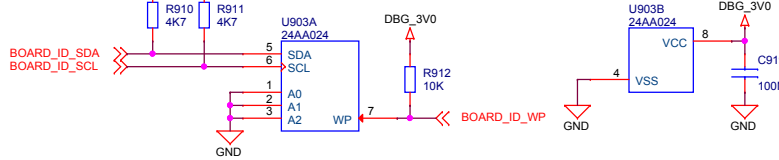

On-board Debugger Power

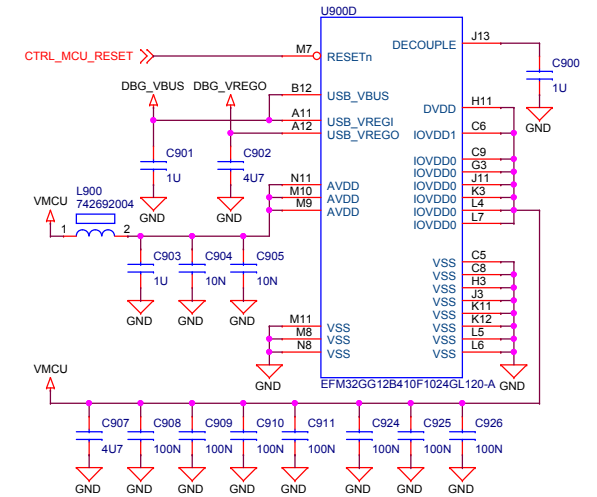

Test Points

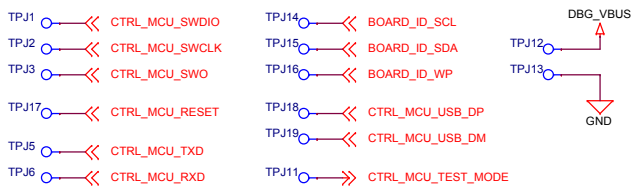

Mech

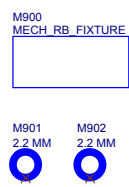

		Schematic Title	
		Thunderboard EFR32BG22	
Designed: ESH Size: A3		Page Title	
		On-board Debugger	
Approved: JSH		Document number BRD4184B	
Design Created Date: Wednesday, July 31, 2019		Sheet Created Date: Monday, August 12, 2019	
BOM Doc No:		Sheet Modified Date: Monday, June 08, 2020	
		Revision A02	
		Sheet 5 of 5	