

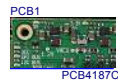

## EFR32xG24B Radio Board

### 2.4 GHz 20 dBm

Board Function	Page
Title Page	1
RF, Antenna and Power	2
EFR32 Signal Assignments	3
WSTK Connectors & Board ID	4



LEGAL NOTICE:  
SILICON LABORATORIES INC. ("SILICON LABS") AND/OR ITS LICENSORS DO NOT WARRANT THE ACCURACY OR COMPLETENESS OF THIS SCHEMATIC OR ANY INFORMATION CONTAINED WITHIN THIS SCHEMATIC. IT IS PROVIDED "AS-IS" FOR REFERENCE ONLY. SILICON LABS DOES NOT WARRANT THAT THIS DESIGN WILL MEET THE SPECIFICATIONS, BE SUITABLE FOR YOUR APPLICATION OR FIT FOR ANY PARTICULAR PURPOSE, OR WILL OPERATE IN YOUR IMPLEMENTATION. SILICON LABS AND ITS LICENSORS DO NOT WARRANT THAT THE DESIGN IMPLIED IN THIS SCHEMATIC IS PRODUCTION-WORTHY. YOU SHOULD COMPLETELY VALIDATE AND TEST YOUR DESIGN IMPLEMENTATION TO CONFIRM SYSTEM FUNCTIONALITY FOR YOUR APPLICATION.

## Revision History

Rev.	Description
A00	Initial release.
A01	U1 with new factory calibrations, mounted C3.

		Board Name	
		<b>EFR32xG24B 2.4 GHz 20 dBm Radio Board</b>	
<b>SILICON LABS</b>		Page Title	
		<b>Title Page</b>	
Designed <b>TAB</b>	Approved <b>RGU</b>	Board Number	Revision
Size <b>A3</b>	Sheet Modified Date <b>Tuesday, February 15, 2022</b>	<b>BRD4187C</b>	<b>A01</b>
COPYRIGHT SILICON LABORATORIES INC. 2020    CONFIDENTIAL – SUBJECT TO TERMS OF USE			Sheet 1 of 4

# Antenna & Radio Interface

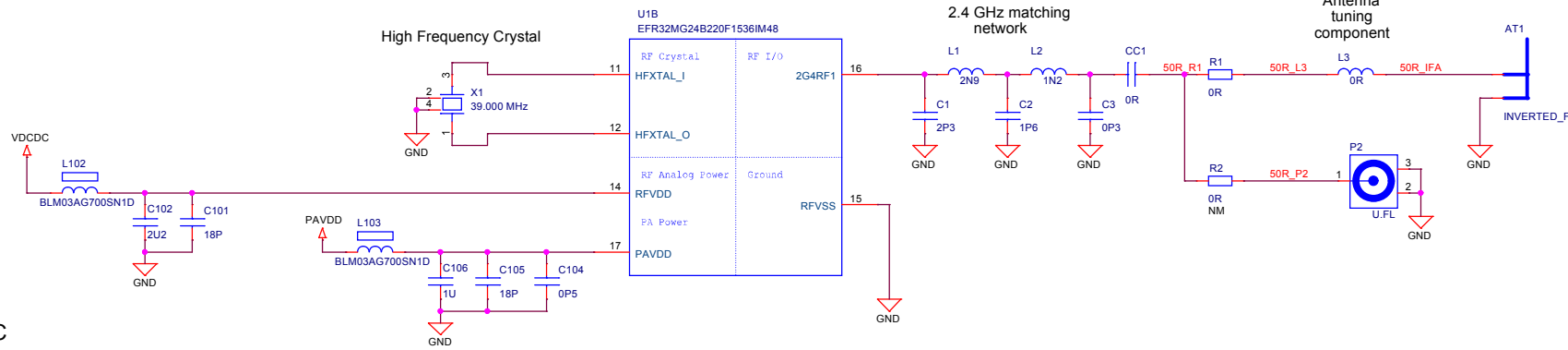

# PAVDD Configuration

	Power Config 1 VMCU to PAVDD	Power Config 2 DCDC to PAVDD
R210	Mount	Not mount
R211	Not mount	Mount

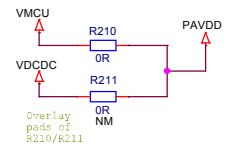

# RF Shielding

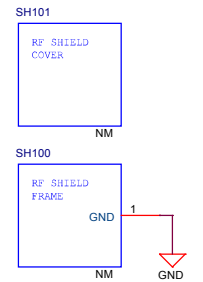

# Power & Decoupling

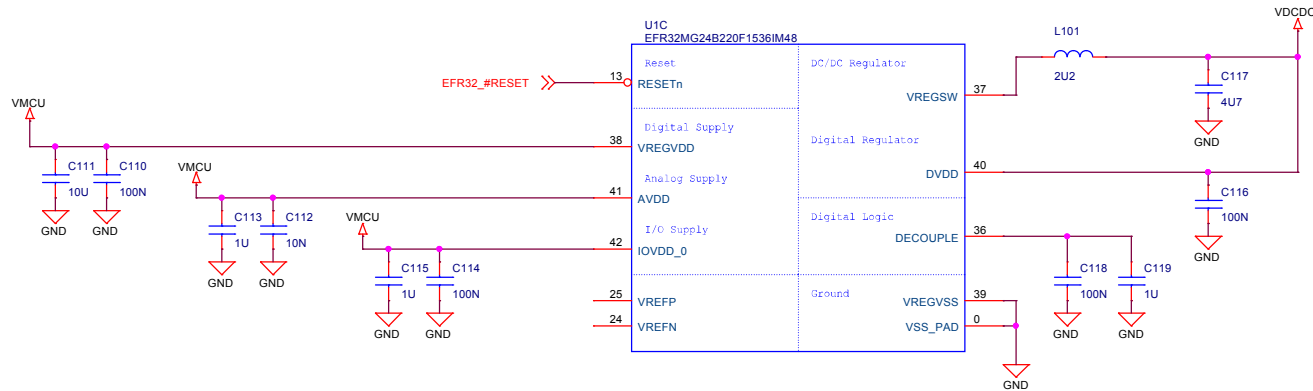

		Board Name		
		<b>EFR32xG24B 2.4 GHz 20 dBm Radio Board</b>		
Designed TAB		Page Title		
		<b>RF &amp; Power</b>		
Size A3		Approved RGU	Board Number <b>BRD4187C</b>	Revision <b>A01</b>
Sheet Modified Date Tuesday, February 15, 2022		Copyright Silicon Laboratories Inc. 2020		Confidential - Subject to Terms of Use
				Sheet 2 of 4

# Pin Mapping

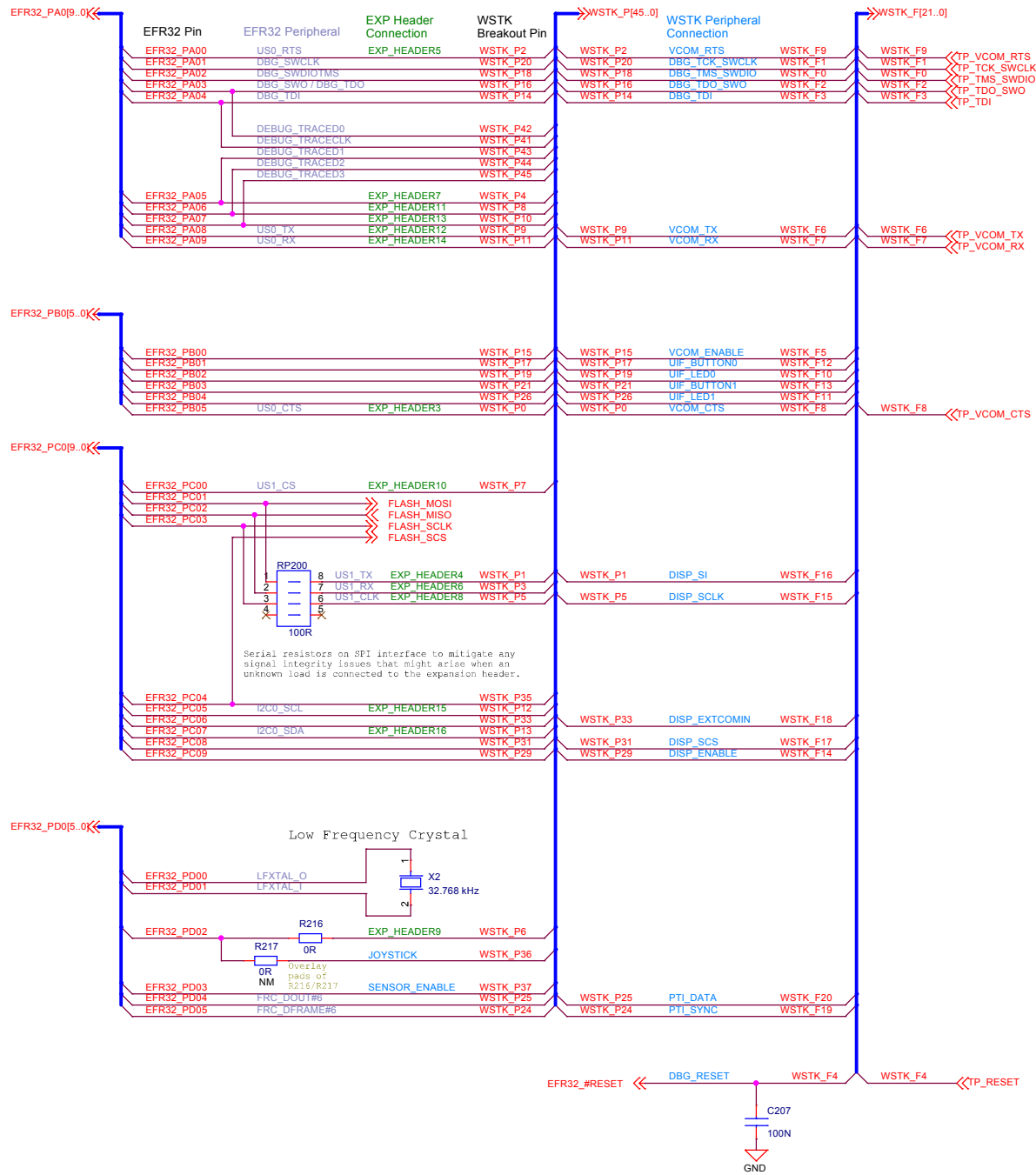

# I/O Port Pins

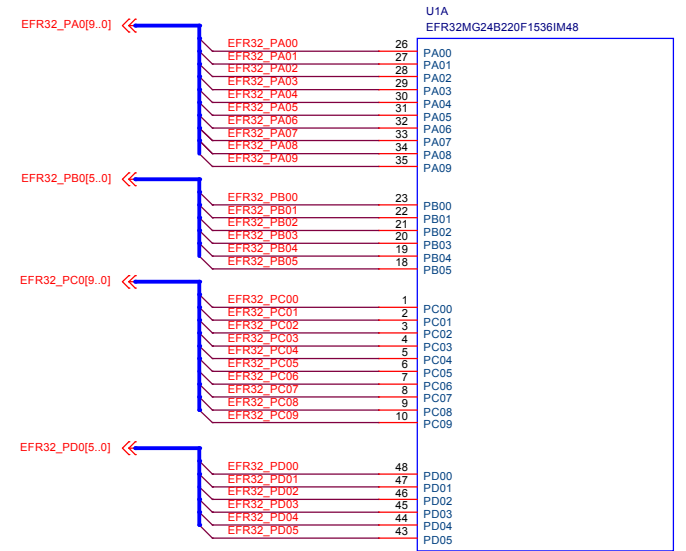

# Serial Flash

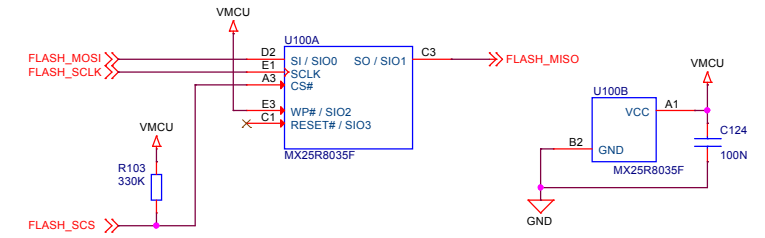

		Board Name	
		<b>EFR32xG24B 2.4 GHz 20 dBm Radio Board</b>	
Designed <b>TAB</b>		Page Title	
		<b>EFR32 Signal Assignments</b>	
Size <b>A3</b>		Board Number <b>BRD4187C</b>	Revision <b>A01</b>
Sheet Modified Date Tuesday, February 15, 2022		COPYRIGHT SILICON LABORATORIES INC. 2020    CONFIDENTIAL – SUBJECT TO TERMS OF USE	
		Sheet 3 of 4	

# WSTK Connectors

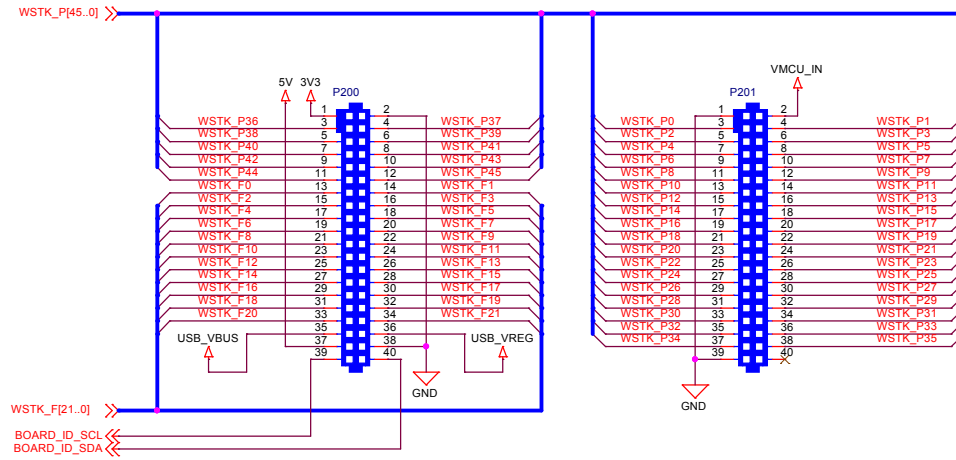

# WSTK Power Decoupling

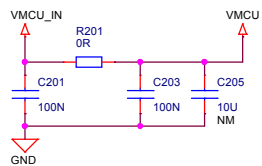

# Board Identification

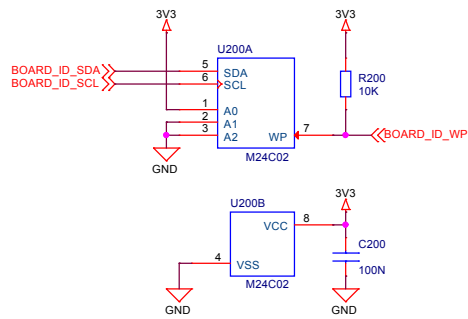

# Test Points

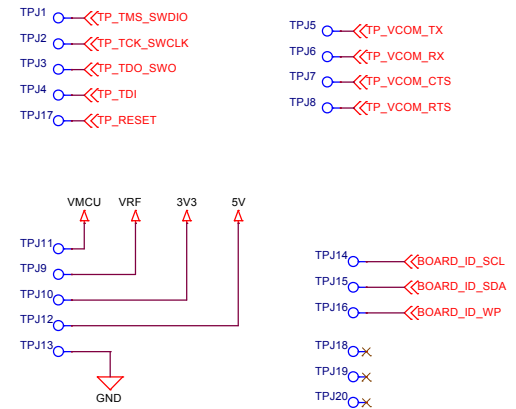

		Board Name	
		<b>EFR32xG24B 2.4 GHz 20 dBm Radio Board</b>	
Designed TAB		Page Title	
		<b>WSTK Connectors &amp; Board ID</b>	
Size	Sheet Modified Date	Board Number	Revision
A3	Tuesday, February 15, 2022	<b>BRD4187C</b>	<b>A01</b>
COPYRIGHT SILICON LABORATORIES INC. 2020    CONFIDENTIAL – SUBJECT TO TERMS OF USE			Sheet 4 of 4