

An Introduction to Digital Control of Switching Power Converters

Geof Potter

April 2004

Applying digital methods to the control of power converters, in particular board-mounted dc/dc converters, offers a rich set of possibilities from which to create new features, improved performance, and much greater product flexibility, and all at lower cost. Power converter operating characteristics dictated by a stored program, rather than the parameters of a set of discrete components, can mean tremendous cost and space savings as well as capacity for real time adaptation of those characteristics, greater sophistication in control algorithms and the ability to generate, store and recall valuable real-time functional data.

Digital signal processors, micro-controllers, flash memory and fast A/D converters will soon do to power conversion technology what they did to 35mm cameras.

This paper is intended to provide a brief, qualitative overview of how a digital control system is implemented in a familiar analog environment, i.e. that of a straightforward, board-mounted DC/DC converter. Terms and techniques discussed here apply to virtually any power supply design, but by no means exhaust the range of design alternatives available.

Where is digital control applied?

There are two areas within a converter module where “control” is applied;

1. active feedback (or feed-forward) schemes driving power switch duty-cycle modulation to produce “regulation”, usually of output voltage. In other words, the primary operational control of the module, and;
2. peripheral functions (such as voltage programming, sequencing, OTP, etc.) that guide and protect the device or communicate with its environment.

Peripheral functions have long been within the scope of digital control methods because necessary speed and complexity are not great. On the other hand, digital control of an active feedback loop, including a pulse modulation process (the “core” of a power converter), has been an elusive prize due to size, cost and power consumption of components for needed for practical operation. To successfully compete with a low cost analog control system, a digital equivalent requires data resolution and “latency” (path delay) numbers that have been available only in large, expensive DSP and A/D converter products. To compound the difficulty, there are few, if any,

integrated devices on the market, at the present time, that contain all the necessary functions to constitute a reasonable power “controller”. Only recently has enough digital device design talent has been brought to bear on the concept of “full digital control” of power converters to produce solutions to those formidable challenges.

We will explore how the “need for speed” is being addressed, suggest where challenges lie for power supply designers trying to apply digital control, and discuss some of the many possibilities for feature enhancement that come with on-board digital apparatus.

Comparison of analog and digital power control architecture.

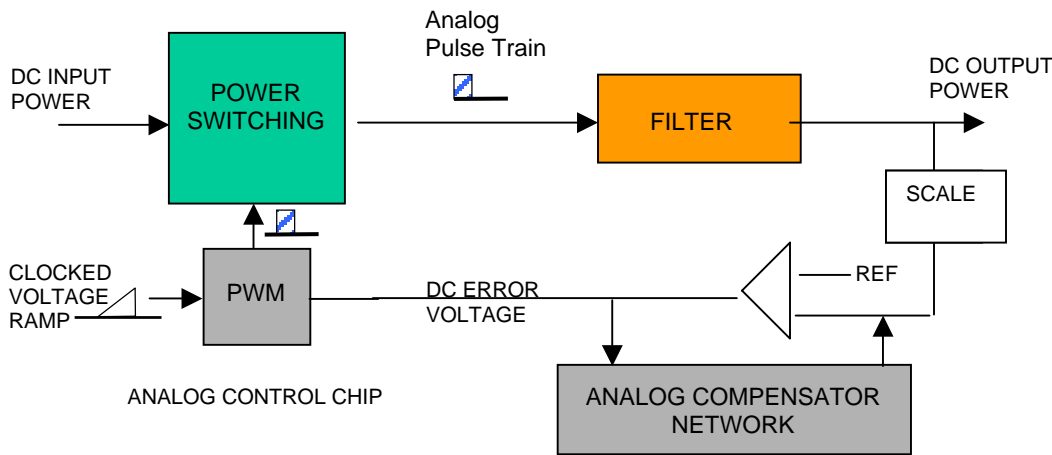

Fig. 1

A typical switching power converter is shown above in Fig. 1. An analog control system provides output voltage regulation by comparing a scaled representation of the output voltage to a reference voltage and amplifying the difference. A resulting “error voltage”, applied to an analog Pulse Width Modulator results in a variable width drive pulse that has an average value equal to the desired output voltage. Amplified in voltage and current (power) by the power switching stage, drive pulses are averaged by the filter to yield a DC output voltage.

As a closed loop system, this circuit requires a control mechanism to insure that the **gain** around the loop (from output sensing through around to the filter) does not exceed unity at any frequency where **phase shift** around the loop reaches 360 degrees. In addition to a built-in 180 degrees necessary for regulation, phase shift around the control loop is caused by delays introduced by reactive elements (capacitors or inductors) and to a smaller degree by operational delays in amplifiers, modulator and switching devices.

Adjustment, or **compensation**, for gain variation and phase shift over a range of frequencies is usually incorporated into error amplifier circuitry to assure that the circuit will be stable when operating under anticipated conditions.

Isolation between input and output may be included in the design, but even with isolation, conceptually most power converters operate as shown in Figure 1.



It is possible to incorporate digital devices, such as “micro-controllers”, into an analog control system like that of Fig. 1. An MCU can be set up to adjust and manage operation of an analog PWM (change switching frequency, for example) but that sort of control is not the subject of this paper. Rather, we are concerned, here, with a control system in which the feedback process is managed entirely by digital techniques. Specifically, the **PWM** function, **error signal**, and **compensator** functions are performed in digital mode.

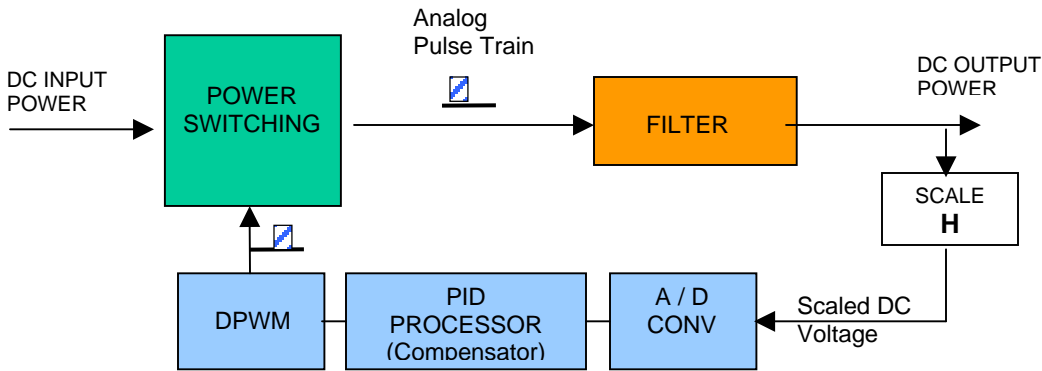

Fig. 2

A digital control system equivalent to that of Fig. 1. is depicted in Fig. 2. Notice that voltage sensing, compensator and pulse width modulator functions are still present but appear under different names. Power switching, scaling and filter functions are exactly the same as in the analog design of Fig. 1.

Working back from the power switching stage, a **Digital Pulse Width Modulator** performs the same drive signal generation function as its analog counterpart, but it does so by “calculating” and then “timing” the desired duration of ON and OFF periods of its output signal. By contrast, an analog PWM usually operates by triggering ON at a clock transition and triggering OFF when a fixed voltage “ramp” reaches a pre-set trip voltage. The distinction is important because it leads to many of the advantages, and challenges, associated with digital control.

Ahead of the DPWM is a **“control law” processor** of some type. Typically a PI or PID¹ style subsystem is used to perform the task of translating a digital representation of output voltage into pulse duration (duty-cycle) information used by the DPWM. It is the job of the PID control element to center the output voltage on a pre-set value and adjust pulse width, in real-time, to provide voltage regulation. It must do so by compensating for gain and phase-shift factors around the control loop, as in the analog version. In digital systems, there are additional phase shift factors arising from time delays in processing the control data stream. The major gain and phase-shift

¹ Proportional Integral Derivative control systems contain factors that determine DC level and dynamic response characteristics of the control loop. These factors are represented as mathematical coefficients that can be manipulated to adjust system performance.



factors present in an analog system (mostly from the output filter), are also present in digital mode, with calculation and A/D conversion delay factors added.

Moving farther upstream, an Analog-to-Digital (A/D) converter produces digital data that represents output voltage. Each binary “word”, containing upwards of 8 bits of data, is sent at a high clock rate to the PID control law processor. Word length and A/D reference voltage set the precision to which output voltage can be maintained. In digital systems analog quantities, like voltage, must be represented as a range of discrete values. Spacing between values, or the size of each “bucket”, is set by the number of data bits that define it divided into the total range of voltage over which the A/D conversion stage operates².

Quantization Effects – a digital mode phenomenon

Analog control provides very fine resolution for output voltage adjustment. In principle, a voltage can be adjusted to any arbitrary value limited by loop gain, thermal effects and system noise levels. On the other hand, a digital control loop has a finite set of discrete “set points” resulting from the resolution of “**quantizing elements**” in the system. Our example above (Fig. 2) has two such elements, the A/D converter and the DPWM. Resolution is defined as the number of states that can be uniquely represented by the control “word” involved. An *n* bit control word can assume 2^n states since each bit has 2 values.

When a power switching stage is modulated by a pulse stream containing 2^n possible pulse widths, then after averaging by the filter stage, the number of discrete output voltage values = $V_{in} \cdot 2^n$. Output voltage **resolution** corresponds to the space between voltage levels = $V_{in} / 2^n$

One or more discrete output voltage “buckets” must correspond to the desired output voltage “set-point” of the power module, including a tolerance.

Example: $V_{out} = 1.20$ volts +/- 1% Required resolution = $\Delta V_{out} = 1\%$

Number of A/D bits required³ = $n = \text{int} [\log_2 (V_{out}/\Delta V_{out})] = \text{int} [\log_2 (100)] = 7$

An A/D converter output word consisting of 7 or more bits will have at least one state that corresponds to the desired value, within 1%. Scaling factor, H, matches the A/D reference to a desired output voltage range to include the specified set point. A/D *resolution* insures that the set point tolerance can be met.

If resolution in a downstream quantizer (DPWM) is less than the A/D converter, then the A/D will be unable to find an output voltage that lies within its “zero error” bucket. That is, one A/D converter LSB change will cause the DPWM to move the output voltage by more than one LSB equivalent. As a result, the system will appear to hunt for a stable output value and will “bounce”

² In this case, the A/D “stage” includes the A/D converter, its power source and scaling factor. In fact, H is used to “scale” an A/D operating range to match the desired output voltage.

³ H, the scaling factor, does not enter into a calculation for A/D resolution as long as the A/D converter reference is at least 78.2% of the device operating range.



up and down around the desired value. This phenomenon is called **“limit cycling”**. Fig. 3 shows the concept graphically.

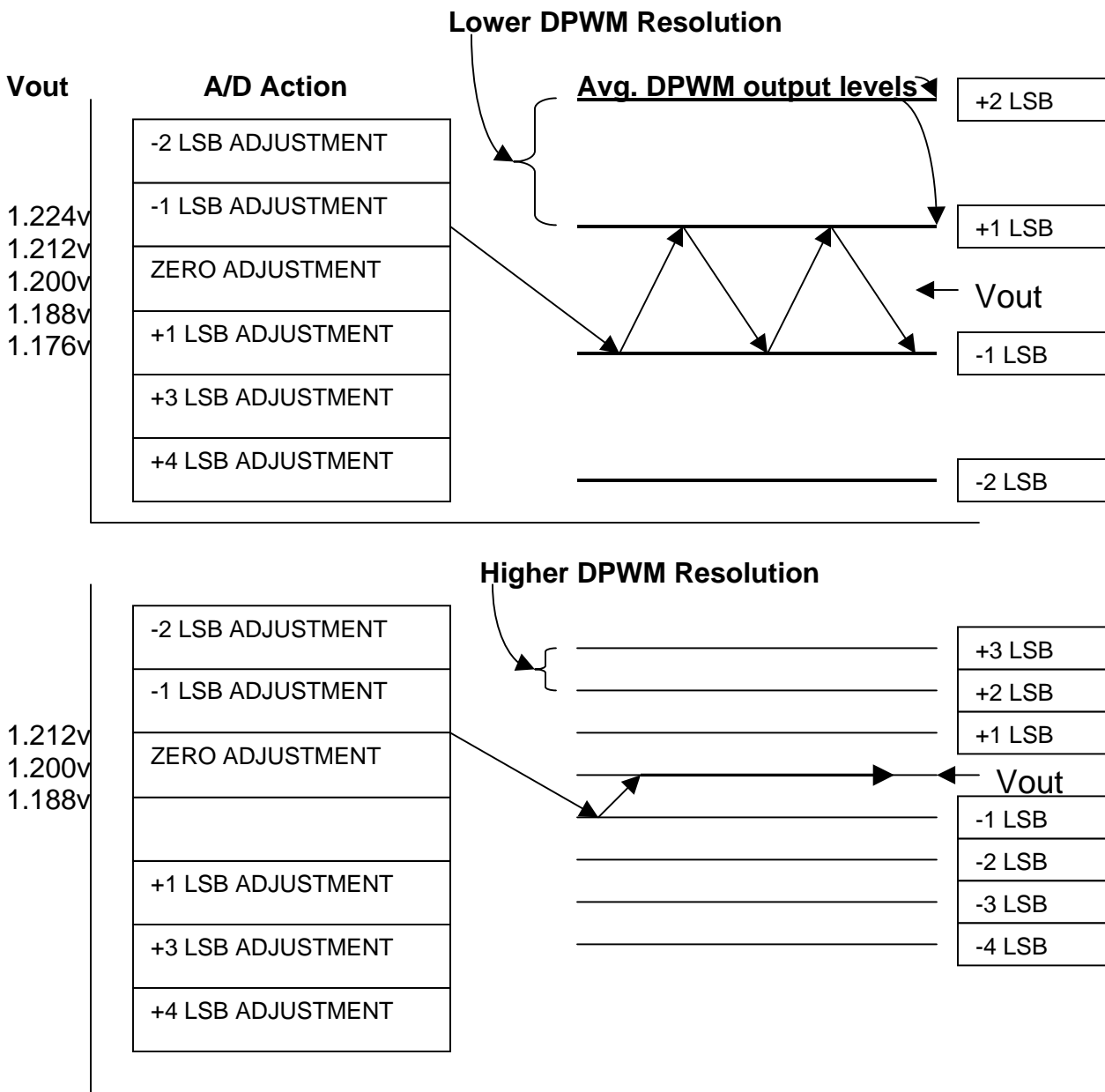

Fig. 3

One requirement for a stable power converter output is that any quantizer downstream of the first A/D stage must have higher resolution.

Achieving higher resolution can be a challenge when tight control of output voltage is needed. Improving resolution requires increasing clock speed because the clock pulse rate sets the



maximum number of bits that can be generated in a fixed time period. Power converters generally operate at fixed switching rates (say, 1 MHz) so the DPWM has a defined time interval (i.e. 1 usec) in which to compress at least 2^{n+1} bits.

For example, if a DPWM required 10 bit resolution (9 bit A/D), and must operate⁴ at 1 MHz, then each LSB at its input corresponds to $1\text{usec}/2^{10}$ or 977 picoseconds. To generate time steps of that size, the DPWM clock must operate at $1/977 \cdot 10^{-12}$ Hz or 1.024 GHz. While clock rates of that magnitude, or higher, can be produced in IC devices, they become expensive and require driving power that is likely to exceed practical values in most DC/DC conversion products. When it comes to digital control of switching power converters, high switching rates combined with high precision set point accuracy can add up to prohibitive cost and power consumption.

Dither – sometimes pulse jitter can be useful.

Fortunately there are ways to improve the effective resolution of the DPWM without raising its clock rate beyond practical levels. One such method, called “Dither”, uses the fact that the plant (i.e. power stage) output filter averages any pulse train that is fed into it. If every m^{th} output pulse from the DPWM is deliberately adjusted in width by the equivalent of 1 LSB (all other pulses remain normal), then the average value of the resulting pulse train will be increased, or decreased, by an amount equal to $(1/m) \cdot$ resolution of 1 LSB.

Example: 1 LSB at the DPWM input moves the output pulse train average by 10mv. If every 4th pulse is shortened by an amount of time corresponding to 10 mv, then the average output voltage through the filter will be reduced by $10\text{mv}/4$ or 2.5mv. The net effect is to make the PDWM appear to have higher resolution. An exaggerated example is shown below.

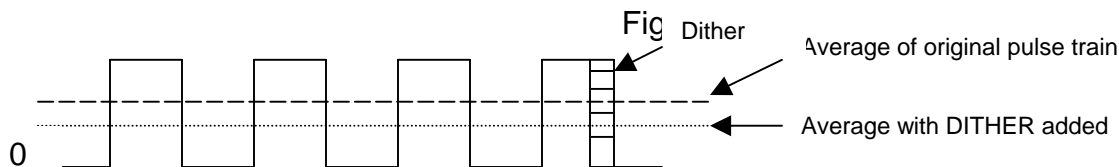

Of course, under the principle of “nothing comes free”, an additional frequency component would be introduced into output ripple, namely that of the modulation being applied, *operating frequency / m*. In practical applications, however, the filter can usually effectively remove this modulating effect.

Control Law Processing

Strictly speaking, the data stream that is fed to our DPWM comes, not directly from the primary A/D converter, but through a control law processor, typically a PID control scheme of some type. It will modify the data received from the A/D but will not affect the resolution of the system.

⁴ Operating frequency refers to the cycling rate of each power device in the switching stage and is a basic design parameter of the power handling stages including the filter.

Output voltage translated into a digital “word” by our A/D converter is modified in the PID control stage according to an equation similar to the one below. Each term of the form $D_x(k)$ represents a word processed at time k .

$$D_c(k+1) = K_p D_e(k) + K_d [D_e(k) - D_e(k - 1)] + K_i D_i(k) + D_{ref}(k)$$

where: $D_c(k+1)$ = the “next” duty cycle command to be translated into the analog domain and sent to the power switches

$$D_i(k) = D_i(k - 1) + D_e(k) \quad \text{last integral factor + error}$$

$$D_e(k) = D_{ref}(k) - D_{out}(k) \quad \text{the “error” term}$$

Each term in the control equation produces a desired adjustment to the word being processed, and hence, to the duty-cycle of the pulses ultimately reaching the power switching stage. Relative weighting of those terms is set by their coefficients. Specifically, the *Proportional Coefficient*, K_p , is a gain factor that determines sensitivity of adjustment.

K_i , called the *Integral Coefficient* causes an adjustment to duty-cycle that is proportional to the length of time an error value has been present. An integral is computed in $D_i(k)$ by adding the present error value to its state from the last sample. An integral term in the equation will drive “error” to zero resulting in centering of the output voltage inside whichever A/D bucket corresponds to the desired set point.

A *Derivative Coefficient*, K_d , compensates for time delays accumulated around the control loop. Time delay results in phase shift that must be corrected to insure that the system is stable. The effect is equivalent to phase boost achieved by adding a Zero into an analog control loop. It also compensates for delay introduced by the K_i term

Obviously, the relative values of the coefficients in the PID algorithm determine the system frequency response, familiar to us as loop gain and phase shift in analog control. As with analog loops, a PID control system must be “tuned” to create whatever system response is desired and guarantee stability. Usually initial values for the coefficients are calculated or transformed mathematically from an analog design. Methods for accomplishing this are beyond the scope of this discussion. It is sufficient to say that manipulation of K_a , K_i and K_d can digitally reproduce most analog control designs. Other compensator algorithms are well known in control theory and could also be applied.

One of the most powerful aspects of power supply control by digital methods lies in the fact that control law coefficients can be contained in a stored program and can be modified, “on-the-fly” if desired (no soldering required), to precisely set overall converter dynamic response, output impedance or other control loop related parameters. Digital control is not only precise, but also independent of thermal drift, aging and component tolerance limitations associated with analog feedback systems. Further, stored coefficients can be changed to create different control



response characteristics in a range of products, custom schemes for individual user applications or perhaps to explore an operational envelope.

Digital control invites “intelligent” manipulation.

Circuits that perform digital functions can, of course, be coupled to a bus structure that enables communication, data storage and sensor manipulation among other functions. Fig. 5 shows an architecture for a hypothetical control IC.

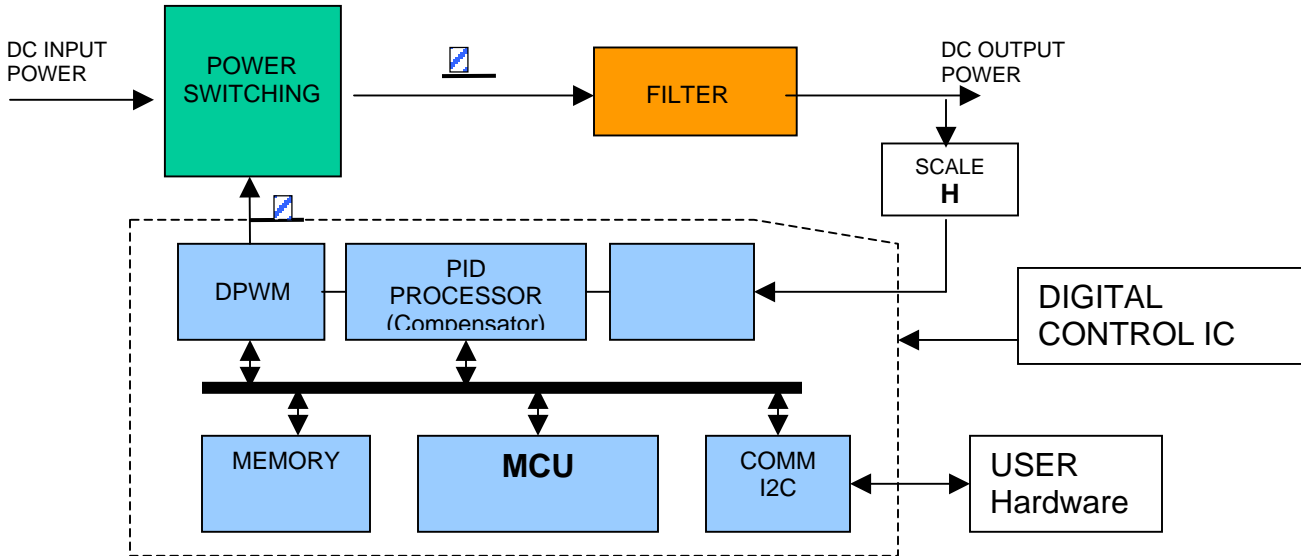

FIG. 4

By including additional sensed input from key points within the converter module, such as temperature, input voltage, output current or even more sophisticated measurements, an integrated control IC (pictured above in Fig. 5) can, with imaginative programming, perform very complex actions.



Probably the most obvious feature of a digital system, with minimal sensor enhancement, is its ability to read out voltage and/or current data to a user through the communications port shown in Fig. 5. It would also be possible to manipulate such data before transfer through the port or perhaps to store it for later access. Other obvious capabilities would include VID programming, turn-on or turn-off trajectory control, and OCP / OVP limit adjustment because all the elements required to manage these things are within program control.

A comprehensive discussion of the power of a digital system such as that of Fig.5 is beyond the intended scope of this paper and is a proper subject for a document of its own. Never-the-less it should be apparent to anyone considering the well know powers of digital processing that an entirely new creative dimension will open to power conversion designers with the advent of comprehensive, *digital mode*, control chips.

References:

- [1] Angel V. Peterchev, Seth R. Sanders
"Quantization Resolution and Limit Cycling in Digitally Controlled PWM Converters" *Applied Power Electronics Conference, 2004*
- [2] Aleksander Prodic, Dragan Maksimovic and Robert W. Erickson
"Design and Implementation of a Digital PWM Controller for a High-Frequency Switching DC-DC Power Converter" *Applied Power Electronics Conference, 2004*

